

### DESCRIPTION

Double acting seal for rotating piston

### MATERIAL ON DYNAMIC SURFACE

Type: Polytetrafluoroethylene + Bronze

Designation: SEALFLON + Bronze

⇒ it can be provided with different fillers according to applications

### MATERIAL ON STATIC SURFACE

Type: Nitril Rubber NBR

Designation: RUBSEAL 70

Hardness: 70 °ShA

⇒ it can be provided with different materials according to working conditions

### MAIN FEATURES

The piston seal type YRB, used preferably for hydraulic joints and rotary joints, is composed of:

- A dynamic seal element which assures exceptional low friction and high speed performance, high compatibility with nearly all media due to the chemical resistance which exceeds that of all other thermoplastics and elastomers

- A standard size O-Ring with low permanent deformation as energizing component on the static side

- Low static and dynamic friction
- High speed allowed
- No tendency of stick-slip
- Can also work for single action
- Space-saving construction and simple groove design
- High compatibility with nearly all fluids (with the right choice of O-Ring material)
- High resistance against extrusion
- High temperature resistance

### FIELD OF APPLICATION

Pressure	≤ 400 bar
Speed	≤ 1 m/s (lubricated and continuous)
(rotating)	≤ 5 m/s (intermittent)
Temperature	-30°C ÷ +130°C (with OR in NBR)
	-30°C ÷ +200°C (with OR in FKM)
Fluids	High compatibility with nearly all fluids (with the right choice of O-Ring material)

### SURFACE ROUGHNESS

Dynamic surface	Ra ≤ 0.3 µm	Rt ≤ 2.5 µm
Static surface	Ra ≤ 1.6 µm	Rt ≤ 6.3 µm

### GAP DIMENSION "g"

The largest gap dimension [mm] appearing in operation on the non-pressurised side:

L	100 BAR	200 BAR	300 BAR
2.2	0.30	0.20	0.10
3.2	0.50	0.30	0.20
4.2	0.50	0.30	0.20
6.3	0.60	0.40	0.30
8.1	0.60	0.40	0.30
9.5	0.90	0.60	0.50
≥ 400 bar ⇒ $g_{max} = H8/f8$			

### LEAD-IN CHAMFERS

L	s
2.2	2.0
3.2	2.5
4.2	3.5

### LEAD-IN CHAMFERS

L	s
6.3	5.0
8.1	6.5
9.5	7.5

- to avoid damaging the seal during installation, housing must have rounded chamfers. Sharp edges and burrs within the installation area of the seal must be removed

# YRB

DOUBLE ACTING SEAL  
FOR ROTATING PISTON

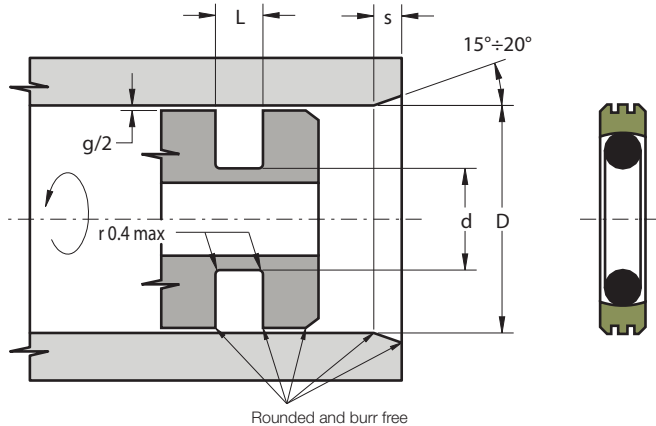

Part.	D <sup>H10</sup>	d <sup>h9</sup>	L <sup>+0.2</sup>	OR
YRB 8 3.1 2.2	8	3.1	2.2	006
YRB 10 5.1 2.2	10	5.1	2.2	009
YRB 12 7.1 2.2	12	7.1	2.2	610
YRB 15 10.1 2.2	15	10.1	2.2	012
YRB 16 11.1 2.2	16	11.1	2.2	013
YRB 18 13.1 2.2	18	13.1	2.2	014
YRB 20 15.1 2.2	20	15.1	2.2	015
YRB 22 17.1 2.2	22	17.1	2.2	016
YRB 25 20.1 2.2	25	20.1	2.2	018
YRB 28 23.1 2.2	28	23.1	2.2	020
YRB 30 25.1 2.2	30	25.1	2.2	022
YRB 32 27.1 2.2	32	27.1	2.2	023
YRB 35 30.1 2.2	35	30.1	2.2	025
YRB 38 33.1 2.2	38	33.1	2.2	027
YRB 40 32.5 3.2	40	32.5	3.2	125
YRB 42 34.5 3.2	42	34.5	3.2	126
YRB 45 37.5 3.2	45	37.5	3.2	127
YRB 48 40.5 3.2	48	40.5	3.2	130
YRB 50 42.5 3.2	50	42.5	3.2	131
YRB 55 47.5 3.2	55	47.5	3.2	134
YRB 60 52.5 3.2	60	52.5	3.2	137
YRB 63 55.5 3.2	63	55.5	3.2	139
YRB 65 57.5 3.2	65	57.5	3.2	140
YRB 70 62.5 3.2	70	62.5	3.2	144
YRB 75 67.5 3.2	75	67.5	3.2	147

Part.	D <sup>H10</sup>	d <sup>h9</sup>	L <sup>+0.2</sup>	OR
YRB 80 69 4.2	80	69.0	4.2	232
YRB 85 74 4.2	85	74.0	4.2	845
YRB 90 79 4.2	90	79.0	4.2	235
YRB 95 84 4.2	95	84.0	4.2	236
YRB 100 89 4.2	100	89.0	4.2	238
YRB 105 94 4.2	105	94.0	4.2	240
YRB 110 99 4.2	110	99.0	4.2	241
YRB 115 104 4.2	115	104.0	4.2	243
YRB 120 109 4.2	120	109.0	4.2	244
YRB 125 114 4.2	125	114.0	4.2	246
YRB 130 119 4.2	130	119.0	4.2	247
YRB 140 125.5 6.3	140	124.5	6.3	352
YRB 150 134.5 6.3	150	134.5	6.3	355
YRB 160 144.5 6.3	160	144.5	6.3	358
YRB 170 154.5 6.3	170	154.5	6.3	361
YRB 180 164.5 6.3	180	164.5	6.3	363
YRB 190 174.5 6.3	190	174.5	6.3	364
YRB 200 184.5 6.3	200	184.5	6.3	366
YRB 210 194.5 6.3	210	194.5	6.3	367
YRB 220 204.5 6.3	220	204.5	6.3	369
YRB 240 224.5 6.3	240	224.5	6.3	372
YRB 250 234.5 6.3	250	234.5	6.3	374
YRB 280 264.5 6.3	280	264.5	6.3	377
YRB 300 284.5 6.3	300	284.5	6.3	379
YRB 320 304.5 6.3	320	304.5	6.3	381
YRB 350 329 8.1	350	329.0	8.1	455
YRB 360 339 8.1	360	339.0	8.1	456
YRB 400 379 8.1	400	379.0	8.1	458
YRB 420 399 8.1	420	399.0	8.1	460
YRB 450 429 8.1	450	429.0	8.1	463
YRB 480 459 8.1	480	459.0	8.1	465
YRB 500 479 8.1	500	479.0	8.1	467
YRB 520 499 8.1	520	499.0	8.1	468
YRB 550 529 8.1	550	529.0	8.1	470
YRB 600 579 8.1	600	579.0	8.1	472
YRB 650 629 8.1	650	629.0	8.1	474
YRB 700 672 9.5	700	672.0	9.5	670x8.4
YRB 750 722 9.5	750	722.0	9.5	720x8.4

Other sizes not present in the above table can be provided in according to the following scheme:

# YRB

DOUBLE ACTING SEAL  
FOR ROTATING PISTON

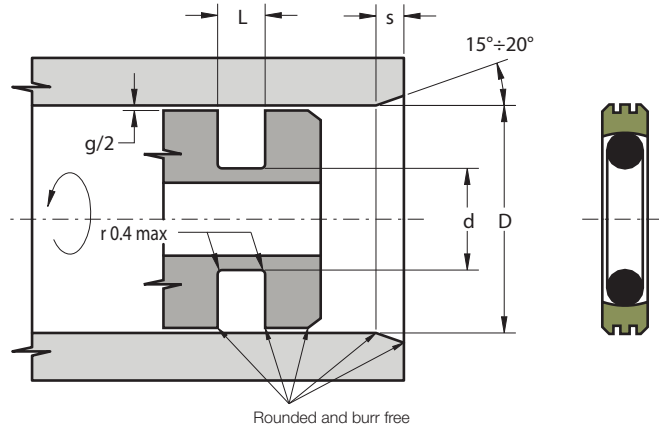

D	d	L	S. OR
8 ÷ 39.9	D - 4.9	2.20	1.78
40 ÷ 79.9	D - 7.5	3.20	2.62
80 ÷ 132.9	D - 11.0	4.20	3.53
133 ÷ 329.9	D - 15.5	6.30	5.34
330 ÷ 669.9	D - 21.0	8.10	6.99
670 ÷ 999.9	D - 28.0	9.50	8.40