

DESCRIPTION

Double acting piston seal

MATERIAL ON DYNAMIC SURFACE

Type: Polytetrafluoroethylene + carbon
 Designation: SEALFLON

⇒ it can be provided with different fillers according to applications

MATERIAL ON STATIC SURFACE

Type: Nitril Rubber NBR
 Designation: RUBSEAL 70
 Hardness: 70 °ShA

⇒ it can be provided with different materials according to working conditions

MAIN FEATURES

The piston seal type YL, mainly suitable for low pressure conditions or pneumatic field, is composed of:

- A dynamic seal element which assures exceptional low friction and high speed performance, high compatibility with nearly all media due to the chemical resistance which exceeds that of all other thermoplastics and elastomers
- A standard size O-Ring with low permanent deformation as energizing component on the static side
- Low static and dynamic friction, also without lubrication
- No tendency of stick-slip
- Space-saving construction and simple groove design
- Good resistance against extrusion
- High compatibility with nearly all fluids (with the right choice of O-Ring material)
- High speed allowed
- High temperature resistance

FIELD OF APPLICATION

Pressure	≤ 160 bar
Speed	≤ 2 m/s
Temperature	-30°C ÷ +130°C (con OR in NBR) -30°C ÷ +200°C (con OR in FKM)
Fluids	High compatibility with nearly all fluids (with the right choice of O-Ring material)

SURFACE ROUGHNESS

Dynamic surface	Ra ≤ 0.3 µm	Rt ≤ 2.5 µm
Static surface	Ra ≤ 1.6 µm	Rt ≤ 6.3 µm

GAP DIMENSION “g”

The largest gap dimension appearing in operation on the non-pressurised side must comply with the ISO H8/f7:

LEAD-IN CHAMFERS		LEAD-IN CHAMFERS	
L	s	L	s
2	3.0	6	6.0
3	3.5	8	8.0
4	4.5		

- to avoid damaging the seal during installation, housing must have rounded chamfers. Sharp edges and burrs within the installation area of the seal must be removed

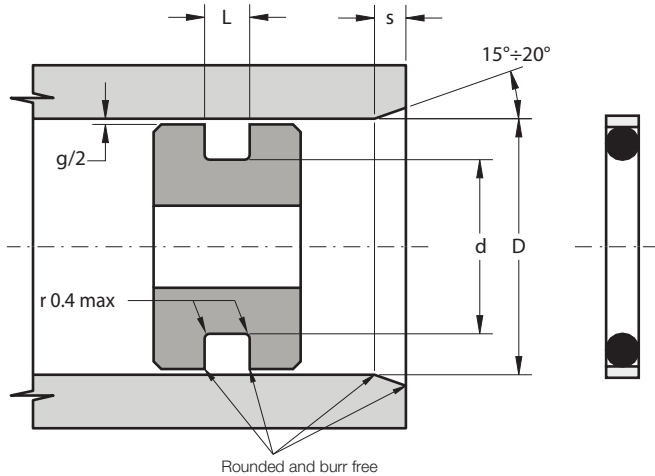

Part.	D ^{H8}	d ^{h9}	L ^{+0.2}	OR
YL 007-8	8	3.4	2	007
YL 008-9	9	4.4	2	008
YL 009-10	10	5.5	2	009
YL 010-11	11	6.5	2	010
YL 011-12	12	7.4	2	011
YL 012-14	14	9.5	2	012
YL 013-15	15	10.4	2	013
YL 613-16	16	9.8	3	613
YL 111-17	17	10.8	3	111
YL 614-18	18	11.8	3	614
YL 113-20	20	13.8	3	113
YL 114-22	22	15.8	3	114
YL 116-25	25	18.8	3	116
YL 211-28	28	20.0	4	211
YL 212-30	30	22.0	4	212
YL 213-32	32	24.0	4	213
YL 215-35	35	27.0	4	215
YL 216-36	36	28.0	4	216
YL 217-38	38	30.0	4	217
YL 218-40	40	32.0	4	218
YL 219-42	42	34.0	4	219
YL 221-45	45	37.0	4	221
YL 824-48	48	40.0	4	824

Part.	D ^{H8}	d ^{h9}	L ^{+0.2}	OR
YL 325-50	50	38.3	6	325
YL 326-55	55	43.5	6	326
YL 327-56	56	44.3	6	327
YL 328-60	60	48.3	6	328
YL 329-63	63	51.3	6	329
YL 330-65	65	53.3	6	330
YL 331-70	70	58.4	6	331
YL 333-75	75	62.9	6	333
YL 334-80	80	68.0	6	334
YL 336-85	85	72.9	6	336
YL 337-90	90	78.0	6	337
YL 339-95	95	82.9	6	339
YL 340-100	100	88.0	6	340
YL 344-110	110	97.9	6	344
YL 347-120	120	107.9	6	347
YL 348-125	125	112.5	6	348
YL 860-130	130	117.5	6	860
YL 428-140	140	124.5	8	428
YL 431-150	150	134.5	8	431
YL 434-160	160	144.5	8	434
YL 437-170	170	153.7	8	437
YL 874-180	180	163.7	8	874
YL 440-190	190	173.7	8	440
YL 442-200	200	183.7	8	442
YL 678-250	250	233.7	8	678
YL 682-280	280	263.7	8	682
YL 451-300	300	283.7	8	451

Other sizes not present in the above table can be provided on request