

DESCRIPTION

Double acting seal for rotating rod

MATERIAL ON DYNAMIC SURFACE

Type: Polytetrafluoroethylene + Bronze

Designation: SEALFLON + Bronze

⇒ it can be provided with different fillers according to applications

MATERIAL ON STATIC SURFACE

Type: Nitril Rubber NBR

Designation: RUBSEAL 70

Hardness: 70 °ShA

⇒ it can be provided with different materials according to working conditions

MAIN FEATURES

The rod seal type XRB, used preferably for hydraulic joints and rotary joints, is composed of:

- A dynamic seal element which assures exceptional low friction and high speed performance, as well as high compatibility with nearly all media due to the chemical resistance which exceeds that of all other thermoplastics and elastomers
- A standard size O-Ring with low permanent deformation as energizing component on the static side

- Low static and dynamic friction
- High speed allowed
- No tendency of stick-slip
- Can also work for single action
- Space-saving construction and simple groove design
- High compatibility with nearly all fluids (with the right choice of O-Ring material)
- High resistance against extrusion
- High temperature resistance

FIELD OF APPLICATION

Pressure	≤ 400 bar
Speed	≤ 1 m/s (lubricated and continuous)
(rotating)	≤ 5 m/s (intermittent)
Temperature	-30°C ÷ +130°C (with OR in NBR)
	-30°C ÷ +200°C (with OR in FKM)
Fluids	High compatibility with nearly all fluids (with the right choice of O-Ring material)

SURFACE ROUGHNESS

Dynamic surface	Ra ≤ 0.3 µm	Rt ≤ 2.5 µm
Static surface	Ra ≤ 1.6 µm	Rt ≤ 6.3 µm

GAP DIMENSION "g"

The largest gap dimension [mm] appearing in operation on the non-pressurised side:

L	100 BAR	200 BAR	300 BAR
2.2	0.30	0.20	0.10
3.2	0.50	0.30	0.20
4.2	0.50	0.30	0.20
6.3	0.60	0.40	0.30
8.1	0.60	0.40	0.30
9.5	0.90	0.60	0.50
≥ 400 bar ⇒ g _{max} = H8/f8			

LEAD-IN CHAMFERS

L	S	L	S
2.2	2.0	6.3	5.0
3.2	2.5	8.1	6.5
4.2	3.5	9.5	7.5

- to avoid damaging the seal during installation, housing must have rounded chamfers. Sharp edges and burrs within the installation area of the seal must be removed

XRB

DOUBLE ACTING SEAL
FOR ROTATING ROD

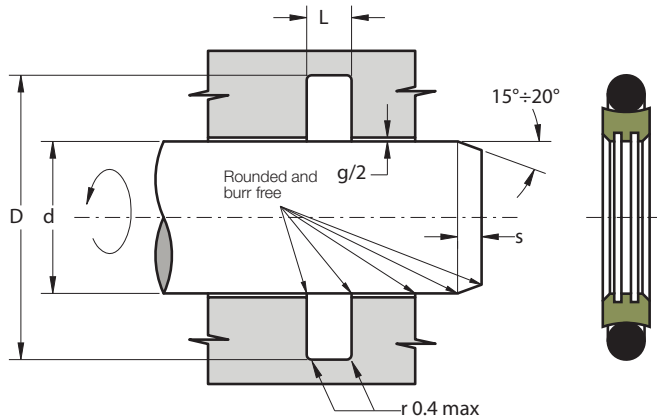

Part.	d ^{f8}	D ^{H9}	L ^{+0.2}	OR
XRB 6 10.9 2.2	6	10.9	2.2	011
XRB 8 12.9 2.2	8	12.9	2.2	012
XRB 10 14.9 2.2	10	14.9	2.2	013
XRB 12 16.9 2.2	12	16.9	2.2	015
XRB 14 18.9 2.2	14	18.9	2.2	016
XRB 15 19.9 2.2	15	19.9	2.2	017
XRB 16 20.9 2.2	16	20.9	2.2	017
XRB 18 22.9 2.2	18	22.9	2.2	019
XRB 20 27.5 3.2	20	27.5	3.2	119
XRB 22 29.5 3.2	22	29.5	3.2	120
XRB 25 32.5 3.2	25	32.5	3.2	122
XRB 28 35.5 3.2	28	35.5	3.2	124
XRB 30 37.5 3.2	30	37.5	3.2	125
XRB 32 39.5 3.2	32	39.5	3.2	126
XRB 35 42.5 3.2	35	42.5	3.2	128
XRB 36 43.5 3.2	36	43.5	3.2	129
XRB 40 51 4.2	40	51	4.2	224
XRB 42 53 4.2	42	53	4.2	828
XRB 45 56 4.2	45	56	4.2	830
XRB 48 59 4.2	48	59	4.2	832
XRB 50 61 4.2	50	61	4.2	833
XRB 52 63 4.2	52	63	4.2	228
XRB 55 66 4.2	55	66	4.2	836

Part.	d ^{f8}	D ^{H9}	L ^{+0.2}	OR
XRB 56 67 4.2	56	67	4.2	229
XRB 60 71 4.2	60	71	4.2	839
XRB 63 74 4.2	63	74	4.2	841
XRB 65 76 4.2	65	76	4.2	232
XRB 70 81 4.2	70	81	4.2	846
XRB 75 86 4.2	75	86	4.2	235
XRB 80 91 4.2	80	91	4.2	236
XRB 85 96 4.2	85	96	4.2	238
XRB 90 101 4.2	90	101	4.2	240
XRB 95 106 4.2	95	106	4.2	241
XRB 100 111 4.2	100	111	4.2	242
XRB 105 116 4.2	105	116	4.2	244
XRB 110 121 4.2	110	121	4.2	246
XRB 115 126 4.2	115	126	4.2	247
XRB 120 131 4.2	120	131	4.2	249
XRB 125 136 4.2	125	136	4.2	251
XRB 130 141 4.2	130	141	4.2	252
XRB 135 146 4.2	135	146	4.2	254
XRB 140 151 4.2	140	151	4.2	255
XRB 145 156 4.2	145	156	4.2	257
XRB 150 161 4.2	150	161	4.2	258
XRB 160 171 4.2	160	171	4.2	259
XRB 170 181 4.2	170	181	4.2	261
XRB 180 191 4.2	180	191	4.2	263
XRB 190 201 4.2	190	201	4.2	264
XRB 200 215.5 6.3	200	215.5	6.3	369
XRB 210 225.5 6.3	210	225.5	6.3	371
XRB 220 235.5 6.3	220	235.5	6.3	373
XRB 240 255.5 6.3	240	255.5	6.3	376
XRB 250 265.5 6.3	250	265.5	6.3	377
XRB 280 301 8.1	280	301	8.1	452
XRB 300 321 8.1	300	321	8.1	453
XRB 320 341 8.1	320	341	8.1	455
XRB 350 371 8.1	350	371	8.1	457
XRB 360 381 8.1	360	381	8.1	458
XRB 400 421 8.1	400	421	8.1	461
XRB 420 441 8.1	420	441	8.1	462
XRB 450 471 8.1	450	471	8.1	465
XRB 480 501 8.1	480	501	8.1	467
XRB 500 521 8.1	500	521	8.1	469

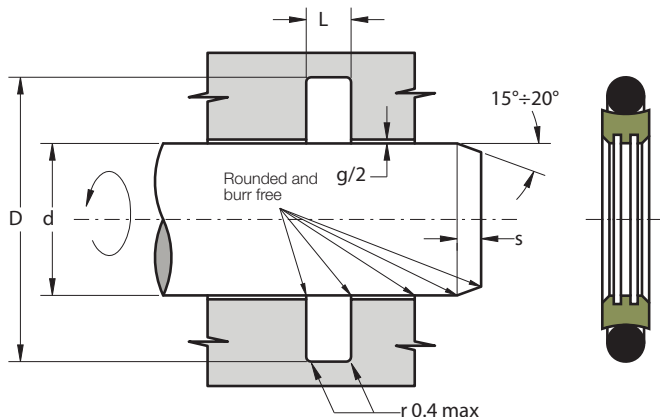

Part.	d ^{f8}	D ^{H9}	L ^{+0.2}	OR
XRB 520 541 8.1	520	541	8.1	470
XRB 550 571 8.1	550	571	8.1	471
XRB 600 621 8.1	600	621	8.1	473
XRB 650 678 9.5	650	678	9.5	660x8.4
XRB 700 728 9.5	700	728	9.5	710x8.4
XRB 750 778 9.5	750	778	9.5	760x8.4

Other sizes not present in the above table can be provided in according to the following scheme:

d	D	L	S. OR
6 ÷ 18.9	d + 4.9	2.20	1.78
19 ÷ 37.9	d + 7.5	3.20	2.62
38 ÷ 199.9	d + 11.0	4.20	3.53
200 ÷ 255.9	d + 15.5	6.30	5.34
256 ÷ 649.9	d + 21.0	8.10	6.99
650 ÷ 999.9	d + 28.0	9.50	8.40