

DESCRIPTION

Double acting rod seal

MATERIAL ON DYNAMIC SURFACE

Type: Polytetrafluoroethylene + carbon

Designation: SEALFLON

⇒ it can be provided with different fillers according to applications

MATERIAL ON STATIC SURFACE

Type: Nitril Rubber NBR

Designation: RUBSEAL 70

Hardness: 70 °ShA

⇒ it can be provided with different materials according to working conditions

MAIN FEATURES

The rod seal type XL, mainly suitable for low pressure conditions or pneumatic field, is composed of:

- A dynamic seal element which assures exceptional low friction and high speed performance, as well as high compatibility with nearly all media due to the chemical resistance which exceeds that of all other thermoplastics and elastomers.
- A standard size O-Ring with low permanent deformation as energizing component on the static side

- Low static and dynamic friction, also without lubrication
- No tendency of stick-slip
- Space-saving construction and simple groove design
- Good resistance against extrusion
- High compatibility with nearly all fluids (with the right choice of O-Ring material)
- High speed allowed
- High temperature resistance

FIELD OF APPLICATION

Pressure	≤ 160 bar
Speed	≤ 2 m/s
Temperature	-30°C ÷ +130°C (with OR in NBR) -30°C ÷ +200°C (with OR in FKM)
Fluids	High compatibility with nearly all fluids (with the right choice of O-Ring material)

SURFACE ROUGHNESS

Dynamic surface	Ra ≤ 0.3 µm	Rt ≤ 2.5 µm
Static surface	Ra ≤ 1.6 µm	Rt ≤ 6.3 µm

GAP DIMENSION "g"

The largest gap dimension appearing in operation on the non-pressurised side must comply with the ISO f7/H8:

LEAD-IN CHAMFERS		LEAD-IN CHAMFERS	
L	s	L	s
2	3.0	6	6.0
3	3.5	8	8.0
4	4.5		

- to avoid damaging the seal during installation, housing must have rounded chamfers. Sharp edges and burrs within the installation area of the seal must be removed

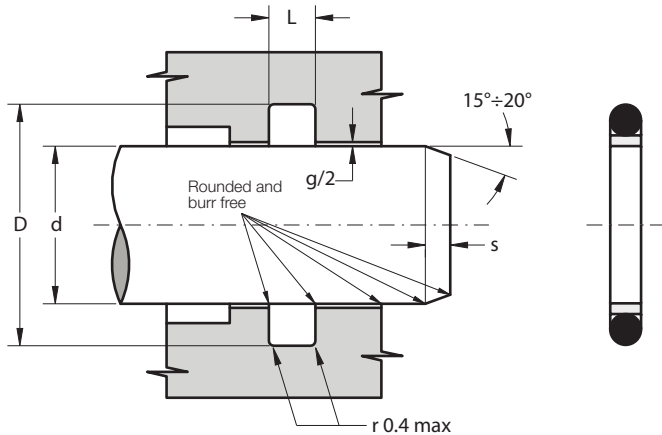

Part.	d ^{f7}	D ^{H9}	L ^{+0.2}	OR
XL 610-5	5	9.5	2	610
XL 011-6	6	10.5	2	011
XL 012-8	8	12.5	2	012
XL 614-10	10	16.2	3	614
XL 113-12	12	18.2	3	113
XL 114-14	14	20.2	3	114
XL 809-15	15	21.1	3	809
XL 617-16	16	22.2	3	617
XL 116-18	18	24.1	3	116
XL 118-20	20	26.2	3	118
XL 119-22	22	28.2	3	119
XL 121-25	25	31.2	3	121
XL 217-28	28	36.0	4	217
XL 218-30	30	38.0	4	218
XL 219-32	32	39.9	4	219
XL 221-35	35	42.9	4	221
XL 824-38	38	46.0	4	824
XL 825-40	40	48.0	4	825
XL 224-42	42	50.0	4	224
XL 225-45	45	53.0	4	225
XL 329-50	50	61.6	6	329
XL 331-55	55	66.7	6	331
XL 331-56	56	67.6	6	331
XL 333-60	60	71.7	6	333

Part.	d ^{f7}	D ^{H9}	L ^{+0.2}	OR
XL 334-63	63	74.7	6	334
XL 334-65	65	76.6	6	334
XL 336-70	70	81.7	6	336
XL 338-75	75	87.1	6	338
XL 339-80	80	92.1	6	339
XL 341-85	85	97.1	6	341
XL 342-90	90	102.1	6	342
XL 344-95	95	107.1	6	344
XL 345-100	100	112.1	6	345
XL 348-110	110	122.0	6	348
XL 428-120	120	135.5	8	428
XL 429-125	125	140.5	8	429
XL 431-130	130	145.5	8	431
XL 434-140	140	155.5	8	434
XL 437-150	150	165.5	8	437
XL 439-160	160	175.5	8	439
XL 878-170	170	186.3	8	878
XL 442-180	180	196.3	8	442
XL 884-190	190	206.3	8	884
XL 445-200	200	216.3	8	445
XL 449-250	250	266.3	8	449
XL 686-280	280	296.3	8	686
XL 453-300	300	316.3	8	453

Other sizes not present in the above table can be provided on request