

DESCRIPTION

Semicompact rod seal with an additional sealing lip and active backup ring

MATERIAL OF SEAL

Type: Polyurethane
 Designation: SEALPUR 93
 Hardness: 93 °ShA

MATERIAL OF ANTI-EXTRUSION RING

Type: Acetal resin
 Designation: BEARITE

MAIN FEATURES

This seal is mainly used with high pressure and the backup ring offsets large gaps without extrusion.

Wear and dry run are largely prevented by additional lubricant retained within the gap created by the secondary lip. In some cases this second sealing lip may even act as a substitute for a costly tandem sealing system when complete sealing under certain working conditions can only be achieved by two seals placed one behind the other in separate housing. It's designed to be less sensitive to pressure fluctuations than typical "U" seals.

The material used to produce this seal is a polyurethane compound that ensures excellent properties on wear-resistance, extended service life and resistance against extrusion.

- Very high resistance against extrusion (backup ring)
- Good sealing performance as well as at low pressure
- Extended service life
- Excellent wear-resistance
- Good temperature resistance
- Insensitive to pressure fluctuation
- Easy installation without expensive auxiliaries

FIELD OF APPLICATION

Pressure	≤ 500 bar
Speed	≤ 0.5 m/s
Temperature	-40°C ÷ +100°C
Fluids	Hydraulic oils (mineral oil based). <i>For other fluids contact our technical department</i>

SURFACE ROUGHNESS

Dynamic surface	Ra ≤ 0.3 µm	Rt ≤ 2.5 µm
Static surface	Ra ≤ 1.6 µm	Rt ≤ 6.3 µm

GAP DIMENSION "g"

The largest gap dimension appearing in operation on the non-pressurised side:

• 200 bar	0.80 mm
• 300 bar	0.65 mm
• 400 bar	0.50 mm
• 500 bar	0.40 mm

LEAD-IN CHAMFERS

d	S _{MIN}
• less 100	5 mm
• 100÷200	7 mm
• over 200	10 mm

- to avoid damaging the sealing lips during installation, housing must have rounded chamfers. Sharp edges and burrs within the installation area of the seal must be removed

SDA SEMICOMPACT ROD SEAL WITH ANTI-EXTRUSION RING

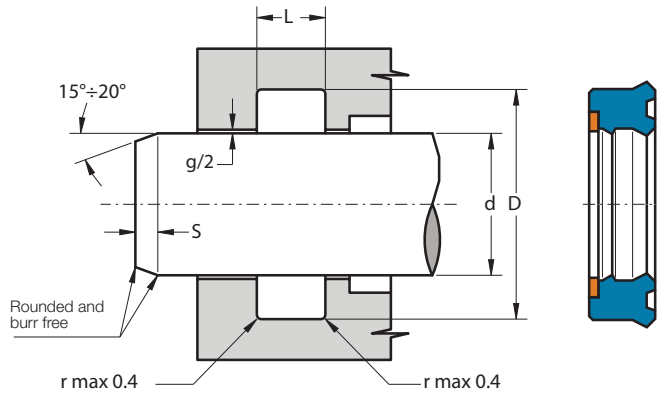

Part.	d ^{f7}	D ^{H10}	L ^{+0.25}
SDA 25 33 5.8	25	33.0	6.3
SDA 40 48 8	40	48.0	9.0
SDA 40 50 10	40	50.0	11.0
SDA 40 52 10	40	52.0	11.0
SDA 40 55 10	40	55.0	11.0
SDA 45 53 9.5	45	53.0	10.5
SDA 45 55 10	45	55.0	11.0
SDA 45 60 10	45	60.0	11.0
SDA 50 60 10	50	60.0	11.0
SDA 50 65 10	50	65.0	11.0
SDA 55 65 10	55	65.0	11.0
SDA 56 71 11.5	56	71.0	12.5
SDA 60 70 12.5	60	70.0	13.5
SDA 60 75 12	60	75.0	13.0
SDA 60 80 12	60	80.0	13.0
SDA 63 75 12	63	75.0	13.0
SDA 63 78 11.5	63	78.0	12.5
SDA 63 83 12	63	83.0	13.0
SDA 65 75 12	65	75.0	13.0
SDA 65 80 11.5	65	80.0	12.5
SDA 70 80 7	70	80.0	8.0
SDA 70 85 12	70	85.0	13.0
SDA 70 90 13.5	70	90.0	14.5
SDA 75 90 12	75	90.0	13.0

Part.	d ^{f7}	D ^{H10}	L ^{+0.25}
SDA 75 95 13.5	75	95.0	14.5
SDA 80 88 9	80	88.0	10.0
SDA 80 95 11	80	95.0	12.0
SDA 80 96 9.5	80	96.0	10.5
SDA 80 100 11.5	80	100.0	12.5
SDA 80 100 13.5	80	100.0	14.5
SDA 90 105 8.5	90	105.0	9.5
SDA 90 105 12	90	105.0	13.0
SDA 90 110 12	90	110.0	13.0
SDA 95 115 13.5	95	115.0	14.5
SDA 100 108 8	100	108.0	9.0
SDA 100 110 12.5	100	110.0	13.5
SDA 100 113 12.5	100	113.0	13.5
SDA 100 120 13.5	100	120.0	14.5
SDA 110 120 13.5	110	120.0	14.5
SDA 110 125 12	110	125.0	13.0
SDA 110 130 11.5	110	130.0	12.5
SDA 120 135 11.5	120	135.0	12.5
SDA 120 140 11.5	120	140.0	12.5
SDA 120 140 15	120	140.0	16.0
SDA 130 145 12	130	145.0	13.0
SDA 135 150 12	135	150.0	13.0
SDA 140 155 12	140	155.0	13.0