

DESCRIPTION

Rod wiper with shoulder

MATERIAL

Type: Polyurethane
 Designation: SEALPUR 93
 Hardness: 93 °ShA

MAIN FEATURES

The function of the SAG wiper ring is to prevent introduction of dust, dirt and foreign matter into the system.

This is achieved by a special wiper lip which produces a very effective cleaning action, prevents the development of scores, protects the guiding parts and extends the service life of the axial moving rod seals.

A flush fitting with the outside diameter reduces moisture entering the groove.

The internal ribs give stability and prevent twisting and sticking of the wiper in the groove.

The material used to produce this wiper is a polyurethane compound that ensures excellent properties in case of dry run, an increased wear-resistance and an extended service life due to good resistance against ozone and radiation caused by weather conditions.

- Extended service life
- External flush fitting for a good housing protection
- Low cost solution
- Excellent wear-resistance
- Space-saving construction
- No close tolerances are necessary
- Easy installation without expensive auxiliaries

FIELD OF APPLICATION

Speed	≤ 0.8 m/s
Temperature	-40°C ÷ +100°C
Fluids	Hydraulic oils (mineral oil based). <i>For other fluids contact our technical department</i>

SURFACE ROUGHNESS

Dynamic surface	Suitable for rod seal system	
Static surface	Ra ≤ 1.6 µm	Rt ≤ 6.3 µm

LEAD-IN CHAMFERS

d	S MIN
• less 100	5 mm
• 100÷200	7 mm
• over 200	10 mm

- Any pressure loads on the back of the rings should be avoided
- Sharp edges and burrs within the installation area must be removed

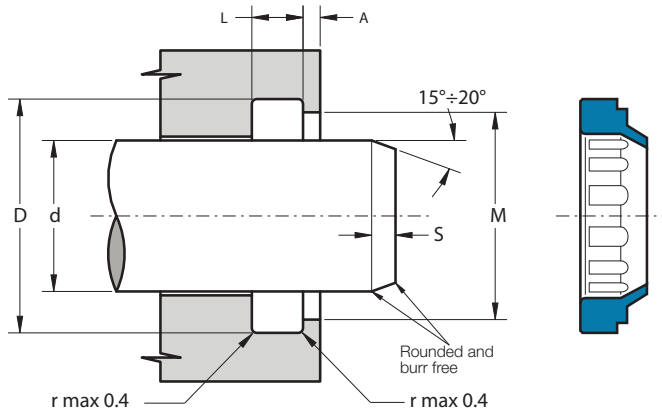

Part.	d ^{f7}	D ^{±0.1}	L ^{+0.15}	M ^{H11}	A ^{±0.1}
SAG 6	6	10	2	9	1
SAG 7	7	11	2	10	1
SAG 10/A	10	16	2.6	14	1
SAG 12	12	20	4	18	1
SAG 14/A	14	20	2.6	18	1
SAG 16	16	24	4	22	1
SAG 16/A	16	20.7	3.7	19	0.8
SAG 16/B	16	20.7	2.2	19	0.8
SAG 18	18	26	4	24	1
SAG 20	20	28	4	26	1
SAG 22	22	30	4	28	1
SAG 24	24	32	4	30	1
SAG 25	25	33	4	31	1
SAG 25/A	25	33.6	5.5	31.4	4
SAG 28	28	36	4	34	1
SAG 30	30	38	4	36	1
SAG 30/A	30	36	4	34	1
SAG 30/B	30	47.5	3	45.5	1.5
SAG 32	32	40	4	38	1
SAG 35	35	43	4	41	1
SAG 36	36	44	4	42	1
SAG 38	38	46	4	44	1
SAG 40	40	48	4	46	1
SAG 42	42	50	4	48	1
SAG 45	45	53	4	51	1

Part.	d ^{f7}	D ^{±0.1}	L ^{+0.15}	M ^{H11}	A ^{±0.1}
SAG 50	50	58	4	56	1
SAG 54	54	62	4	60	1
SAG 55	55	63	4	61	1
SAG 56	56	64	4	62	1
SAG 60	60	68	4	66	1
SAG 63	63	71	4	69	1
SAG 65	65	73	4	71	1
SAG 70	70	78	4	76	1
SAG 75	75	83	4	81	1
SAG 80	80	88	4	86	1
SAG 85	85	93	4	91	1
SAG 90	90	98	4	96	1
SAG 90/A	90	100	5.5	96	2
SAG 97/B	97	107	7	103	2
SAG 100	100	108	4	106	1
SAG 100/A	100	108	6	103.5	2
SAG 110	110	122	5.5	119	1.5
SAG 110/A	110	120	5.5	116	2
SAG 118/B	118	128	7	124	2
SAG 120/A	120	132	8.2	125	2.5
SAG 132/A	132	142	5.5	138	2
SAG 140/A	140	152	8.2	145	2.5
SAG 140/B	140	150	7	146	2
SAG 152/A	152	162	5.5	158	2
SAG 172/A	172	182	5.5	178	2
SAG 194/A	194	204	5.5	200	2

Inch sizes

SAG 3000	76.2	86.2	3.1	82.5	1.9
----------	------	------	-----	------	-----