

### DESCRIPTION

Rod bi-directional wiper

### MATERIAL

Type: Polyurethane  
 Designation: SEALPUR 93  
 Hardness: 93 °ShA

### MAIN FEATURES

The functions of the SAB bi-directional rod wiper are:

- to prevent introduction of dust, dirt and foreign matter into the system; this is achieved by a special wiper lip which produces a very effective cleaning action, prevents the development of scores, protects the guiding parts and extends the service life of the axial moving rod seals.
- to retain residual oil film on the rod; the asymmetric lips are designed to differentiate the behaviour of the lips on the static and dynamic surfaces: the static lips are flexible and more sensitive to pressure fluctuations; the dynamic lip is shorter and stronger to concentrate load against the dynamic surface.

The material used to produce this wiper is a polyurethane compound that ensures excellent properties in case of dry run, an increased wear-resistance and an extended service life due to good resistance against ozone and radiation caused by weather conditions.

- Retaining residual oil film
- Extended service life
- Insensitive to structural deflections
- Excellent wear-resistance
- Space-saving construction
- No close tolerances are necessary
- Easy installation without expensive auxiliaries

### FIELD OF APPLICATION

Pressure	≤ 15 bar
Speed	≤ 0.8 m/s
Temperature	-40°C ÷ +100°C
Fluids	Hydraulic oils (mineral oil based). <i>For other fluids contact our technical department</i>

### SURFACE ROUGHNESS

Dynamic surface	Ra ≤ 0.3 µm	Rt ≤ 2.5 µm
Static surface	Ra ≤ 1.6 µm	Rt ≤ 6.3 µm

### LEAD-IN CHAMFERS

d	S <sub>MIN</sub>
• less 100	5 mm
• 100÷200	7 mm
• over 200	10 mm

- To avoid damaging the sealing lips during installation, housing must have rounded chamfers. Sharp edges and burrs within the installation area of the seal must be removed

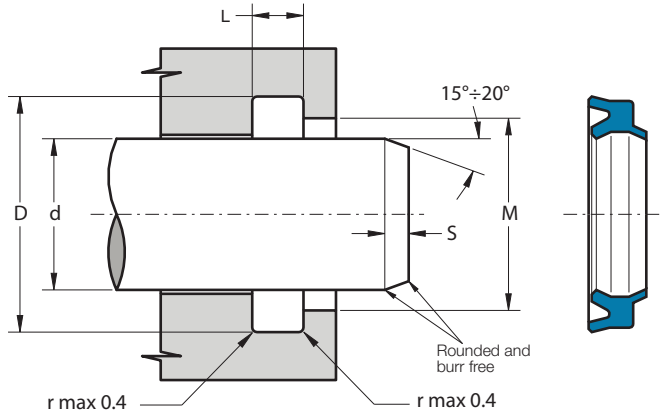

Part.	d <sup>f7</sup>	D <sup>H10</sup>	L <sup>+0.2</sup>	M <sup>+0.2</sup>
SAB 10 20 6	10	20.0	6.5	14.0*
SAB 12	12	18.6	3.8	15.0
SAB 12 26 6.6	12	26.0	7.0	15.0*
SAB 14/ISO	14	20.0	4.0	16.5
SAB 18	18	24.6	3.8	21.0
SAB 20	20	28.6	5.3	23.0
SAB 22	22	30.6	5.3	25.0
SAB 22/ISO	22	28.0	4.0	24.5
SAB 25	25	33.6	5.3	28.0
SAB 28	28	36.6	5.3	31.0
SAB 28/ISO	28	36.0	5.0	31.0
SAB 30	30	38.6	5.3	33.0
SAB 30/A	30	38.0	5.0	33.0
SAB 32	32	40.6	5.3	35.0
SAB 35	35	43.6	5.3	38.0
SAB 36	36	44.6	5.3	39.0
SAB 36/ISO	36	44.0	5.0	39.0
SAB 38	38	46.6	5.3	41.0
SAB 40	40	48.6	5.3	43.0
SAB 40/ISO	40	48.0	5.0	43.0
SAB 42	42	50.6	5.3	45.0
SAB 45	45	53.6	5.3	48.0
SAB 45/ISO	45	53.0	5.0	48.0
SAB 50	50	58.6	5.3	53.0
SAB 50/A	50	58.0	4.0	53.0

Part.	d <sup>f7</sup>	D <sup>H10</sup>	L <sup>+0.2</sup>	M <sup>+0.2</sup>
SAB 50/ISO	50	58.0	5.0	53.0
SAB 55	55	63.6	5.3	58.0
SAB 55/A	55	65.0	6.0	58.0
SAB 60	60	68.6	5.3	63.0
SAB 60/ISO	60	70.0	6.0	63.0
SAB 63	63	71.6	5.3	66.0
SAB 63/ISO	63	73.0	6.0	66.0
SAB 65	65	73.6	5.3	68.0
SAB 65/A	65	75.0	6.0	68.0
SAB 70	70	78.6	5.3	73.0
SAB 75	75	83.6	5.3	78.0
SAB 78/A	78	88.2	7.1	84.0
SAB 80	80	88.6	5.3	83.0
SAB 82/A	82	94.2	7.1	88.0
SAB 85	85	97.2	7.1	91.0
SAB 90	90	102.2	7.1	96.0
SAB 100	100	112.2	7.1	106.0
SAB 104	104	116.2	7.1	110.0
SAB 110	110	122.2	7.1	116.0
SAB 129	129	141.2	7.1	135.0
SAB 154	154	166.2	7.1	160.0
SAB 180	180	192.2	7.1	186.0

\* Open groove assembly