

DESCRIPTION

Guide ring strip to fit cut to size or by meter

MATERIAL

Type: Polytetrafluoroethylene + Bronze
Designation: SEALFLON + Bronze

MAIN FEATURES

The MRB type guide rings have been developed to substitute traditional bronze guides in hydraulic cylinders. They guide the rod or the piston and prevent metallic contact with the cylinder when radial forces act perpendicular to the direction of movement.

Since MRB guide rings are machined, the thickness can be very accurate for high precision guiding.

The compound used for these guides assures exceptional low friction and high speed performance, high compatibility with nearly all media due to the chemical resistance which exceeds that of all other thermoplastics and elastomers.

- Low static and dynamic friction (also without lubrication)
- High speed allowed
- No tendency of stick-slip
- High precision of guiding
- Good damping on radial vibration
- High compatibility with nearly all fluids
- Simple design of groove and assembly
- Good mechanical stability at high temperature
- Easy installation without expensive auxiliaries
- Low resistance to heavy loads

FIELD OF APPLICATION

| | |
|-------------|---|
| Speed | ≤ 5 m/s |
| Temperature | -50°C ÷ +200°C |
| Fluids | High compatibility with nearly all media due to the chemical resistance of the material |

SURFACE ROUGHNESS

| | | |
|-----------------|-------------|-------------|
| Dynamic surface | Ra ≤ 0.3 μm | Rt ≤ 2.5 μm |
| Static surface | Ra ≤ 1.6 μm | Rt ≤ 6.3 μm |

CHOICE OF GUIDE RING WIDTH

A rough estimate of guide width can be calculated with the following formula:

$$h_{mm} \geq \frac{F_N \times k}{p_{N/mm^2} \times d_{mm}}$$

where

| | |
|--------------|--|
| h_{mm} | • guide ring width in mm |
| F_N | • radial load in N |
| k | • safety factor (<i>generally 2</i>) |
| d_{mm} | • diameter in mm |
| p_{N/mm^2} | • surface pressure N/mm ² |
| | 14 a 20 °C |
| | 7 a 80 °C |
| | 5 a 120 °C |

- Before assembly good cleanliness and guides lubrication are recommended.

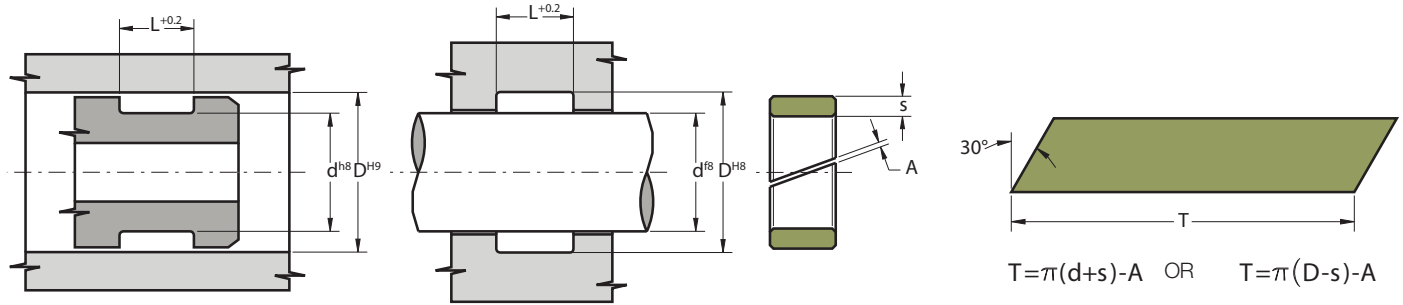

| Part. | s | L | A |
|-----------|-----|------|-----------|
| MRB 15032 | 1.5 | 3.2 | 1.0 ÷ 1.5 |
| MRB 15062 | 1.5 | 6.2 | 1.5 ÷ 3.5 |
| MRB 15063 | 1.5 | 6.3 | 1.5 ÷ 3.5 |
| MRB 15150 | 1.5 | 15.0 | 4.0 ÷ 8.0 |
| MRB 15250 | 1.5 | 25.0 | 6.0 ÷ 8.0 |
| MRB 20042 | 2.0 | 4.2 | 1.0 ÷ 2.0 |
| MRB 20063 | 2.0 | 6.3 | 1.5 ÷ 3.5 |
| MRB 20081 | 2.0 | 8.1 | 2.0 ÷ 5.0 |
| MRB 20097 | 2.0 | 9.7 | 2.0 ÷ 5.0 |
| MRB 20150 | 2.0 | 15.0 | 4.0 ÷ 8.0 |
| MRB 20200 | 2.0 | 20.0 | 4.5 ÷ 8.0 |
| MRB 20250 | 2.0 | 25.0 | 6.0 ÷ 8.0 |
| MRB 20300 | 2.0 | 30.0 | 6.0 ÷ 9.0 |
| MRB 25042 | 2.5 | 4.2 | 1.0 ÷ 2.0 |
| MRB 25056 | 2.5 | 5.6 | 1.0 ÷ 2.0 |
| MRB 25063 | 2.5 | 6.3 | 1.5 ÷ 3.5 |
| MRB 25081 | 2.5 | 8.1 | 2.0 ÷ 5.0 |
| MRB 25097 | 2.5 | 9.7 | 2.0 ÷ 6.0 |
| MRB 25120 | 2.5 | 12.0 | 2.0 ÷ 6.0 |
| MRB 25125 | 2.5 | 12.5 | 2.0 ÷ 6.0 |
| MRB 25128 | 2.5 | 12.8 | 2.0 ÷ 6.0 |
| MRB 25150 | 2.5 | 15.0 | 4.0 ÷ 8.0 |
| MRB 25200 | 2.5 | 20.0 | 4.5 ÷ 8.0 |
| MRB 25250 | 2.5 | 25.0 | 6.0 ÷ 8.0 |

| Part. | s | L | A |
|-----------|-----|------|-----------|
| MRB 25300 | 2.5 | 30.0 | 6.0 ÷ 9.0 |
| MRB 30097 | 3.0 | 9.7 | 2.0 ÷ 6.0 |
| MRB 30128 | 3.0 | 12.8 | 2.0 ÷ 6.0 |
| MRB 30150 | 3.0 | 15.0 | 4.0 ÷ 8.0 |
| MRB 30192 | 3.0 | 19.2 | 4.0 ÷ 8.0 |
| MRB 30200 | 3.0 | 20.0 | 4.5 ÷ 8.0 |
| MRB 30250 | 3.0 | 25.0 | 6.0 ÷ 8.0 |
| MRB 30300 | 3.0 | 30.0 | 6.0 ÷ 9.0 |
| MRB 30350 | 3.0 | 35.0 | 6.0 ÷ 9.0 |
| MRB 30400 | 3.0 | 40.0 | 6.0 ÷ 9.0 |