

DESCRIPTION

Double acting piston seal

MATERIAL ON DYNAMIC SURFACE

Type: Polyurethane
 Designation: SEALPUR 97
 Hardness: 97 °ShA

MATERIAL ON STATIC SURFACE

Type: Nitril Rubber NBR
 Designation: RUBSEAL 70
 Hardness: 70 °ShA

MAIN FEATURES

The piston seal type KPD is composed of:

- A dynamic seal element which assures exceptional high sealing performance. Two compact and small seal edges ensure perfect fluid control and concentrate the load against the dynamic surface. The cavity between the two external seal edges keeps a small quantity of fluid which reduces friction and wear. Side grooves ensure that pressure loads the energizing O-Ring in all work conditions
- A standard size O-Ring with low permanent deformation as energizing component on the static side

- High sealing performance at low pressure also
- Excellent wear-resistance
- Space-saving construction
- Can also work for single action
- Extended service life
- Simple groove design
- Low cost solution
- High resistance against extrusion
- Good temperature resistance
- Easy installation on a solid piston

FIELD OF APPLICATION

Pressure	≤ 400 bar
Speed	≤ 0.5 m/s
Temperature	-30°C ÷ +100°C
Fluids	Hydraulic oils (mineral oil based). <i>For other fluids contact our technical department</i>

SURFACE ROUGHNESS

Dynamic surface	Ra ≤ 0.3 µm	Rt ≤ 2.5 µm
Static surface	Ra ≤ 1.6 µm	Rt ≤ 6.3 µm

GAP DIMENSION “g”

The largest gap dimension appearing in operation on the non-pressurised side:

• 50 bar	1.20 mm
• 100 bar	0.80 mm
• 200 bar	0.40 mm
• 300 bar	0.25 mm
• 400 bar	0.17 mm

LEAD-IN CHAMFERS

D	S MIN
• less 100	5 mm
• 100÷200	7 mm
• over 200	10 mm

- to avoid damaging the sealing lips during installation, housing must have rounded chamfers. Sharp edges and burrs within the installation area of the seal must be removed

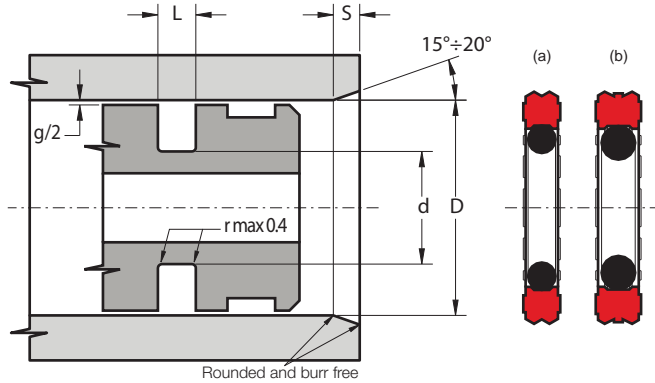

Part.	D ^{H10}	d ^{+0.1}	L ^{+0.2}	OR	TP.
KPD 15 7.5 3.2	15	7.5	3.2	108	(a)
KPD 16 8.5 3.2	16	8.5	3.2	109	(a)
KPD 16 11.1 2.2	16	11.1	2.2	013	(a)
KPD 20 12.5 3.2	20	12.5	3.2	112	(a)
KPD 22 14.5 3.2	22	14.5	3.2	113	(a)
KPD 25 14 4.2	25	14.0	4.2	207	(b)
KPD 25 17.5 3.2	25	17.5	3.2	115	(a)
KPD 30 22.5 3.2	30	22.5	3.2	118	(a)
KPD 30 25.1 2.2	30	25.1	2.2	021	(a)
KPD 32 21 4.2	32	21.0	4.2	211	(b)
KPD 32 24.5 3.2	32	24.5	3.2	119	(a)
KPD 35 24 4.2	35	24.0	4.2	213	(b)
KPD 35 27.5 3.2	35	27.5	3.2	121	(a)
KPD 38 30.5 3.2	38	30.5	3.2	123	(a)
KPD 40 32.5 3.2	40	32.5	3.2	124	(a)
KPD 40 29 4.2	40	29.0	4.2	216	(b)
KPD 40 24.5 6.3	40	24.5	6.3	318	(b)
KPD 42 31 4.2	42	31.0	4.2	217	(b)
KPD 45 29.5 6.3	45	29.5	6.3	320	(b)
KPD 45 34 4.2	45	34.0	4.2	219	(b)
KPD 48 37 4.2	48	37.0	4.2	221	(b)
KPD 49 38 4.2	49	38.0	4.2	222	(b)
KPD 50 34.5 6.3	50	34.5	6.3	324	(b)
KPD 50 39 4.2	50	39.0	4.2	222	(b)

Part.	D ^{H10}	d ^{+0.1}	L ^{+0.2}	OR	TP.
KPD 52 36.5 6.3	52	36.5	6.3	324	(b)
KPD 54 43 4.2	54	43.0	4.2	826	(b)
KPD 55 39.5 6.3	55	39.5	6.3	325	(b)
KPD 55 44 4.2	55	44.0	4.2	224	(b)
KPD 57.16 47.6 4.8	57.16	47.6	4.8	47x4	(b)
KPD 57 46 4.2	57	46.0	4.2	827	(b)
KPD 60 44.5 6.3	60	44.5	6.3	327	(b)
KPD 60 49 4.2	60	49.0	4.2	225	(b)
KPD 63 47.5 6.3	63	47.5	6.3	328	(b)
KPD 63 52 4.2	63	52.0	4.2	226	(b)
KPD 65 49.5 6.3	65	49.5	6.3	328	(b)
KPD 65 54 4.2	65	54.0	4.2	227	(b)
KPD 70 54.5 6.3	70	54.5	6.3	330	(b)
KPD 70 59 4.2	70	59.0	4.2	228	(b)
KPD 75 59.5 6.3	75	59.5	6.3	331	(b)
KPD 75 64 4.2	75	64.0	4.2	230	(b)
KPD 80 64.5 6.3	80	64.5	6.3	333	(b)
KPD 80 69 4.2	80	69.0	4.2	842	(b)
KPD 85 69.5 6.3	85	69.5	6.3	335	(b)
KPD 90 69 8.1	90	69.0	8.1	68x7	(b)
KPD 90 74.5 6.3	90	74.5	6.3	336	(b)
KPD 95 79.5 6.3	95	79.5	6.3	338	(b)
KPD 100 84.5 6.3	100	84.5	6.3	339	(b)
KPD 105 89.5 6.3	105	89.5	6.3	341	(b)
KPD 110 94.5 6.3	110	94.5	6.3	343	(b)
KPD 115 94 8.1	115	94.0	8.1	94x7	(b)
KPD 120 104.5 6.3	120	104.5	6.3	346	(b)
KPD 125 109.5 6.3	125	109.5	6.3	347	(b)
KPD 130 114.5 6.3	130	114.5	6.3	349	(b)
KPD 140 119 8.1	140	119.0	8.1	426	(b)
KPD 140 124.5 6.3	140	124.5	6.3	352	(b)
KPD 150 129 8.1	150	129.0	8.1	430	(b)
KPD 160 139 8.1	160	139.0	8.1	433	(b)
KPD 170 149 8.1	170	149.0	8.1	436	(b)
KPD 180 159 8.1	180	159.0	8.1	438	(b)
KPD 200 179 8.1	200	179.0	8.1	441	(b)
KPD 220 199 8.1	220	199.0	8.1	444	(b)
KPD 250 229 8.1	250	229.0	8.1	447	(b)