

DESCRIPTION

Rod seal with asymmetric lips and double lip

MATERIAL

Type: Polyurethane
 Designation: SEALPUR 93
 Hardness: 93 °ShA

MAIN FEATURES

The rod seal type AD assures a good reaction against shock pressure peaks and low friction in the low pressure range.

The asymmetric lips are designed to differentiate the behaviour of the lips on the static and dynamic surfaces: the static lip is flexible and more sensitive to pressure fluctuations; the dynamic lip is shorter and stronger to concentrate load against the dynamic surface.

Wear and dry run are largely prevented by additional lubricant retained within the gap created by the secondary lip.

The material used to produce this seal is a polyurethane compound that ensures excellent properties on wear-resistance, extended service life and resistance against extrusion.

- Extended service life
- High resistance against extrusion
- Excellent wear-resistance
- Good temperature resistance
- Insensitive to structural deflections
- Easy installation without expensive auxiliaries

FIELD OF APPLICATION

Pressure	≤ 400 bar
Speed	≤ 0.5 m/s
Temperature	-40°C ÷ +100°C
Fluids	Hydraulic oils (mineral oil based). For other fluids contact our technical department

SURFACE ROUGHNESS

Dynamic surface	Ra ≤ 0.3 µm	Rt ≤ 2.5 µm
Static surface	Ra ≤ 1.6 µm	Rt ≤ 6.3 µm

GAP DIMENSION "g"

The largest gap dimension appearing in operation on the non-pressurised side:

• 50 bar	1.20 mm
• 100 bar	0.80 mm
• 200 bar	0.40 mm
• 300 bar	0.25 mm
• 400 bar	0.17 mm

LEAD-IN CHAMFERS

d	S MIN
• less 100	5 mm
• 100÷200	7 mm
• over 200	10 mm

- to avoid damaging the sealing lips during installation, housing must have rounded chamfers. Sharp edges and burrs within the installation area of the seal must be removed

Part.	d ^{f7}	D ^{H10}	L ^{+0.25}
AD 5 10 3.5	5	10.0	4.0
AD 6 11 3.5	6	11.0	4.0
AD 7 12 4	7	12.0	4.5
AD 12 22 8	12	22.0	9.0
AD 16 24 6	16	24.0	7.0
AD 20 26 5	20	26.0	5.5
AD 20 28 6	20	28.0	7.0
AD 22 28 5.8	22	28.0	6.3
AD 22 30 5.8	22	30.0	6.3
AD 22 30 6	22	30.0	7.0
AD 25 33 5.5	25	33.0	6.0
AD 25 33 5.8	25	33.0	6.3
AD 25 33 6.5	25	33.0	7.5
AD 26 36 10	26	36.0	11.0
AD 28 38.7 3.7	28	38.7	4.2
AD 30 40 6	30	40.0	7
AD 30 40 7	30	40.0	8.0
AD 30 40 10	30	40.0	11
AD 30 42 11	30	42.0	12.0
AD 32 40 6.5	32	40.0	7.5
AD 32 41.53 7.9	32	41.53	8.9
AD 32 42 7.3	32	42.0	8.3
AD 35 43 7	35	43.0	8.0
AD 35 45.7 3.7	35	45.7	4.2

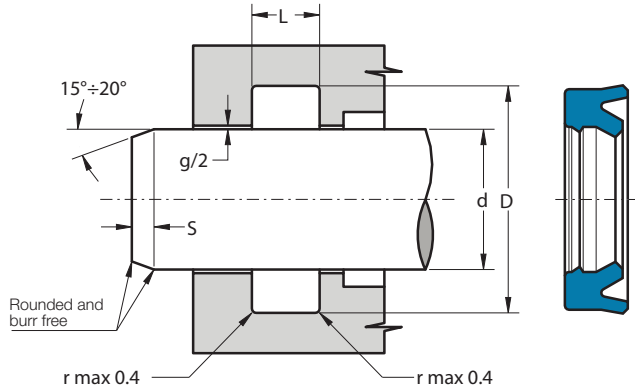

Part.	d ^{f7}	D ^{H10}	L ^{+0.25}
AD 36 46 7	36	46.0	8
AD 36 46 10	36	46.0	11.0
AD 38 48 8	38	48.0	9.0
AD 40 48 5.8	40	48.0	6.3
AD 40 49.52 9.5	40	49.52	10.5
AD 40 50 7	40	50.0	8.0
AD 40 50 8	40	50.0	9.0
AD 40 50 10	40	50.0	11.0
AD 40 52 11	40	52.0	12.0
AD 40 55 10	40	55.0	11.0
AD 40 55.1 5.8	40	55.1	6.3
AD 45 55 7	45	55.0	8.0
AD 45 55 10	45	55.0	11.0
AD 45 60 11.5	45	60.0	12.5
AD 45 60.1 5.8	45	60.1	6.3
AD 50 60 7	50	60.0	8.0
AD 50 60 10	50	60.0	11.0
AD 50 65.1 5.8	50	65.1	6.3
AD 55 63 11.5	55	63.0	12.5
AD 55 65 8.5	55	65.0	9.5
AD 55 65 10	55	65.0	11.0
AD 56 71 11.5	56	71.0	12.5
AD 60 69.3 5.5	60	69.3	6.2
AD 60 70 7	60	70.0	8.0
AD 60 70 14	60	70.0	15.0
AD 65 73 9	65	73.0	10.0
AD 65 73 11.5	65	73.0	12.5
AD 65 80 12	65	80.0	13.0
AD 70 80 12	70	80.0	13.0

Part.	d ^{f7}	D ^{H10}	L ^{+0.25}
AD 70 85 11.5	70	85.0	12.5
AD 75 83 11.5	75	83.0	12.5
AD 75 85 11.5	75	85.0	12.5
AD 78 88 14	78	88.0	15.0
AD 80 95 11.5	80	95.0	12.5
AD 85 93 10	85	93.0	11.0
AD 88.9 101.6 9.5	88.9	101.6	10.5
AD 90 98 11.5	90	98.0	12.5
AD 90 100 11.5	90	100.0	12.5
AD 90 105 11.5	90	105.0	12.5
AD 90 110 14	90	110.0	15.0
AD 95 103 11.5	95	103.0	12.5
AD 99 109 14	99	109.0	15.0
AD 100 110 10	100	110.0	11.0
AD 100 110 11.5	100	110.0	12.5
AD 100 115 12	100	115.0	13.0
AD 100 120 12	100	120.0	13.0
AD 105 115 11.5	105	115.0	12.5
AD 105 120 10	105	120.0	11.0
AD 110 120 10.5	110	120.0	11.5
AD 115 123 11.5	115	123.0	12.5
AD 115 125 12	115	125.0	13.0
AD 118 133 9.8	118	133.0	10.8
AD 120 130 14	120	130.0	15.0
AD 125 133 11.5	125	133.0	12.5
AD 125 135 11	125	135.0	12.0
AD 135 143 11.5	135	143.0	12.5
AD 135 150 11.5	135	150.0	12.5
AD 141 151 14	141	151.0	15.0
AD 145 160 12	145	160.0	13.0
AD 150 160 11	150	160.0	12.0
AD 155 163 11.5	155	163.0	12.5
AD 160 170 11.5	160	170.0	12.5
AD 162 172 14	162	172.0	15.0
AD 175 185 11	175	185.0	12.0
AD 180 190 10	180	190.0	11.0
AD 183 193 14	183	193.0	15.0
AD 207 217 14	207	217.0	15.0

Inch sizes

AD 1250 1750 0250	31.75	44.45	7.0
AD 1500 2000 0335	38.1	50.8	9.5