

# SERIE RAL

Scambiatori di calore ARIA/OLIO

AIR/OIL heat exchangers





## SERIE RAL

### INTRODUZIONE

Il presente catalogo illustra gli scambiatori di calore della serie RAL costruiti in lega d'alluminio ad alta resistenza ottenuta mediante processo costruttivo di saldobrasatura sottovuoto.

Ogni scheda fornisce i dati tecnici relativi allo scambiatore impiegato per il raffreddamento di circuiti oleodinamici e ai ventilatori azionati da motore elettrico o idraulico.

Caratteristiche tecniche massa radiante

- Materiale: alluminio
- Pressione di esercizio: 26 bar
- Pressione di collaudo: 39 bar
- Temperatura massima di esercizio: 120°C
- Consultare IRA RADIATORI per ambienti particolarmente aggressivi

### INSTALLAZIONE

Lo scambiatore deve essere installato in modo tale da evitare la presenza di ostacoli alla circolazione dell'aria, rispettando la distanza minima dalla parete (1/2 diametro ventola) in modo da assicurare il naturale flusso dell'aria di raffreddamento. Può essere montato sia in posizione orizzontale che verticale.

Gli scambiatori di calore aria/olio RAL sono normalmente utilizzati per il raffreddamento di circuiti oleodinamici e installati sulle linee di ritorno, devono essere protetti da urti e vibrazioni meccaniche mediante supporti elastici e collegati all'impianto mediante tubi flessibili.

Per evitare danni che brusche variazioni di portata o eventuali colpi d'ariete o pulsazioni continue arrecano agli scambiatori, si consiglia l'inserimento di una valvola by-pass.

### FLUIDI COMPATIBILI

- Oli minerali
- Emulsioni acqua-olio
- Acqua-glicole

Per altri fluidi consultare IRA RADIATORI

### MANUTENZIONE

#### Pulizia lato olio

Dopo aver smontato lo scambiatore effettuare la pulizia facendo circolare all'interno del radiatore un prodotto sgrassante compatibile con alluminio.

Effettuare un lavaggio con olio idraulico prima di ricollegare lo scambiatore all'impianto.

#### Pulizia lato aria

Eeguire questa operazione mediante aria compressa o acqua. Assicurarsi che la direzione del getto sia paral-

lela alle alette per non danneggiarle.

Per ottenere risultati migliori durante questo tipo di intervento si consiglia di utilizzare un prodotto detergente.

Se l'intasamento dello scambiatore è causato da un accumulo di olio o di grasso, la pulizia potrà essere effettuata con un getto di vapore o di acqua calda.

Durante le operazioni di pulizia il motore elettrico dovrà essere convenientemente protetto.

### SICUREZZA

Nell'utilizzo dello scambiatore occorre attenersi ad alcune importanti avvertenze:

- Non togliere le protezioni delle ventole
- Far eseguire i collegamenti elettrici a personale specializzato seguendo gli schemi allegati
- Le superfici esterne dello scambiatore potrebbero avere temperature molto elevate, occorre quindi prevedere nel montaggio adeguate protezioni o posizionamenti poco accessibili
- Non intervenire sul motore idraulico senza prima aver scollegato i tubi

### ESEMPIO DI SCELTA DELLO SCAMBIATORE

Per effettuare la scelta dello scambiatore si procede secondo l'esempio seguente:

1. Potenza da dissipare: 10 kW
2. Portata olio ISO VG 46: 80 lt/1'
3. Temperatura ingresso olio: 80°C
4. Temperatura ambiente: 50°C
5. Ventilatore elettrico 12 Volt

Occorre calcolare il coefficiente di scambio termico espresso in KW/°C dividendo la potenza da dissipare, per la differenza di temperatura tra olio e ambiente:

$$10KW : 30 \text{ °C } (80\text{°C}-50\text{°C}) = 0,33 \text{ kW/°C}$$

Occorre valutare sui diagrammi di rendimento quale scambiatore a corrente continua esprime la potenza specifica risultante (0,33kW/°C) con una portata di 80 lt/1'



### APPLICAZIONI

- MACCHINE MOVIMENTO TERRA
- MACCHINE AGRICOLE e FORESTALI
- FERROVIARIO
- ENERGIA
- APPARECCHIATURE ELETTRONICHE
- MARINO
- PNEUMATICA e OLEODINAMICA
- VEICOLI ON-ROAD
- SETTORE INDUSTRIALE
- MOTORI ENDOTERMICI

## APPLICATIONS

- EARTH MOVING MACHINES
- FORESTRY AND AGRICULTURAL MACHINES
- RAILWAY INDUSTRY
- ENERGY
- ELECTRONIC DEVICES
- MARINE INDUSTRY
- PNEUMATICS AND HYDRAULICS
- VEHICLES ON-ROAD
- ENDOTHERMIC ENGINES



## INTRODUCTION

This catalogue describes RAL SERIES COOLERS. The cooler element, in high resistance aluminium alloy, is obtained by means of a braze-welding process carried out under vacuum. Each data sheet provides the technical information about the heat exchanger used for cooling oil hydraulic system and about fans operated by electric or hydraulic motor.

Core's technical specification

- Material: aluminium
- Working pressure: 26 bar
- Test pressure: 39 bar
- Max working temperature: 120°C
- Please contact IRA for aggressive ambient

## INSTALLATION

The heat exchanger should be installed in such a way that there should be no obstacles to the air flow, respecting the minimum distance from the wall (1/2 fan diameter) so as to ensure a natural flow of cooling air.

The cooler can be fitted in vertical and horizontal position. RAL series coolers are normally used for cooling hydraulic

circuits and installed on the return lines: they must be protected from impact and mechanical vibrations by support and must be connected to the circuit with flexible pipes. To prevent any damage caused by changes in flow, hammering and pulsations we recommend installing a by-pass valve.

## COMPATIBLE FLUIDS

- Mineral oils
- Water-oil emulsion
- water-Glycol

For other fluid consults IRA RADIATORI

## MAINTENANCE

## Cleaning oil side

After having dismantled the exchanger, carry out the cleaning procedure by circulating de-greasing substance inside the radiator compatible with aluminium. Wash with hydraulic oil before reconnecting the cooler.

## Cleaning air side

Carry out this procedure using water or compressed air. Make sure that the direction of the jet is parallel to the fins so that they are not damaged.

In order to obtain optimal results during this type of procedure we advise using a cleansing agent.

If the blockage of the exchanger is caused by build up of oil or grease, cleaning can be carried out using a jet of steam or hot water.

During cleaning procedures the electric motor must be adequately protected.

## SAFETY

During operation of heat exchangers observe following instructions:

- Do not remove the fan grilles
- Electrical connections must be made by skilled electricians in accordance with the attached electrical diagrams
- Exterior surfaces of heat exchangers may reach high temperatures so adequate guards must be installed or the unit must be mounted in an inaccessible position

- Do not perform work on the hydraulic motor until the hydraulic pipelines have been disconnected

## HOW TO CHOOSE RIGHT HEAT EXCHANGER

To choose right heat exchanger follows the below example:

1. Power to dissipate: 10 KW
2. Oil flow ISO VG 46: 80 lt/1'
3. Inlet oil temperature: 80°C
4. Ambient temperature: 50°C
5. Electric fan 12 Volt

You can calculate the specific coefficient of heat exchange (kW/°C) if you divide the power to dissipate with the difference between oil input temperature and ambient temperature:

$$10KW : 30 \text{ }^{\circ}\text{C} (80^{\circ}\text{C}-50^{\circ}\text{C}) = 0,33 \text{ kW}/^{\circ}\text{C}$$

Note the oil flow (80 lt/1') and specific exchange power (0,33 kW/°C) and research the cooler that has in performance diagram this result with direct electric fan

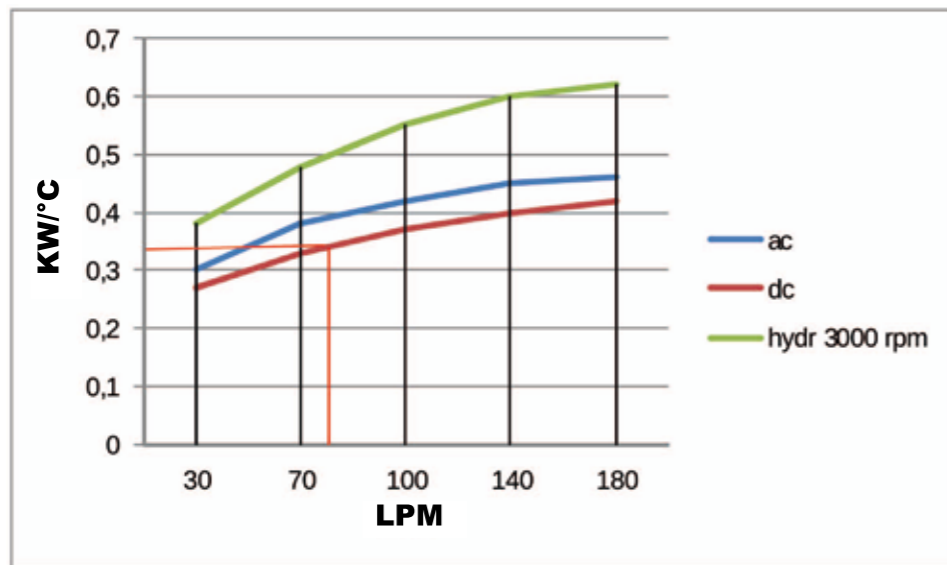

Lo scambiatore selezionato è il modello RAL40/3 - 12/24 V.  
Per la corretta denominazione del prodotto consultare la scheda di CODIFICA PRODOTTO.  
Se non sono conosciuti tutti i dati contattare IRA RADIATORI.

The selected heat exchanger is model RAL40/3 - 12/24 V.  
For a complete description of heat exchanger consul the PRODUCT ORDERING CODE page.  
If you don't know all required data for selecting cooler, please contact IRA RADIATORI.

**Codifica prodotto serie RAL**  
Ordering code RAL series

**RAL40/3V12A40XX**

Serie Series	Modello Model	Ventilazione Fan	A/S	TERM.	ACC/MOD
RAL	40	3	V	12	A40XX

RAL = RADIATORE OLIO ALLUMINIO/ALUMINIUM OIL COOLER

V12 VCC  
V24 VCC  
V230 VAC  
V400 VAC  
V230/400 VAC B14  
GR1  
GR2

A = ASPIRANTE/SUCHING  
S = SOFFIANTE/BLOWING

TERMOSTATI/THERMOSTAT  
30 = 30/38°  
40 = 40/48°  
50 = 50/60°

ACCESSORI / MODIFICHE  
COMPLEMENTS/MODIFICATIONS  
P = PIEDI / FEET  
A = MODIFICA SULLO STANDARD  
A = CHANGE ON STANDARD VERSION

**ESEMPIO:**  
**RAL40/3V12AT40P**  
MODELLO RAL40/3 COMPLETO DI ELETTROVENTOLA 12 VOLT ASPIRANTE, TERMOSTATO FISSO T40/48°C E PIEDI DI FISSAGGIO.

**EXAMPLE:**  
**RAL40/3V12AT40P**  
MODEL RAL40/3 COMPLETE WITH ELECTRIC FAN 12V SUCHING, FIXED THERMOSTAT 40/48°C AND FEET.

**CABLAGGIO 12/24 V - C.C.**  
12/24 V D.C. WIRING

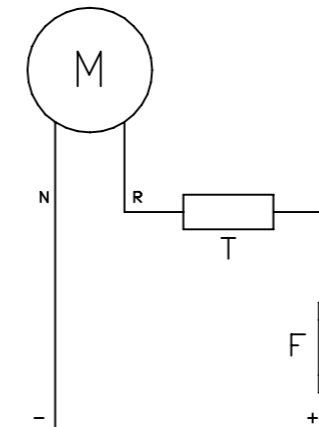

N - NERO / BLACK  
R - ROSSO / RED  
T - TERMOSTATO / THERMO SWITCH  
F - FUSIBILE / FUSE

**CABLAGGIO 230 V - C.A.**  
230 V A.C. WIRING

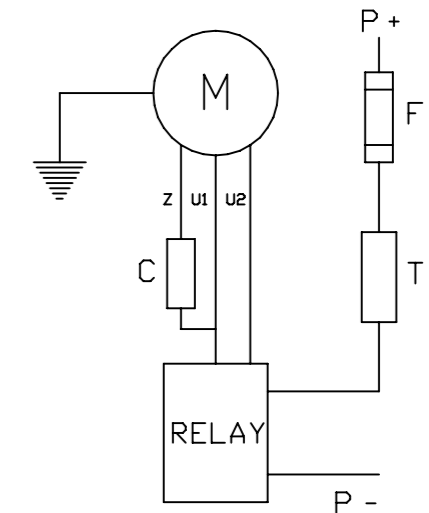

Z - MARRONE / BROWN  
U1 - NERO / BLACK  
U2 - VERDE / GREEN  
T - TERMOSTATO / THERMO SWITCH  
F - FUSIBILE / FUSE  
P - ALIMENTAZIONE A RELE' / RELAY CURRENT SUPPLY  
C - CONDENSATORE / VOLT CAPACITOR

**CABLAGGIO 230/400 V A STELLA**  
230/400V STAR WIRING

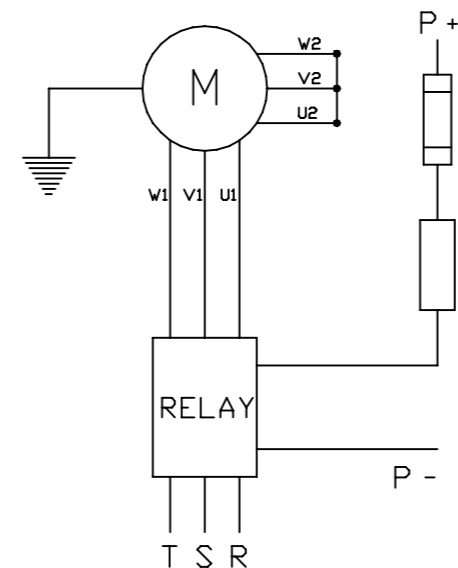

U1 - NERO / BLACK  
U2 - VERDE / GREEN  
V1 - AZZURRO / BLUE  
V2 - BIANCO / WHITE  
W1 - MARRONE / BROWN  
W2 - GIALLO / YELLOW  
T - TERMOSTATO / THERMO SWITCH  
F - FUSIBILE / FUSE  
P - ALIMENTAZIONE RELE' / RELAY CURRENT SUPPLY

**CABLAGGIO 230/400 V A TRIANGOLO**  
230/400V TRIANGLE WIRING

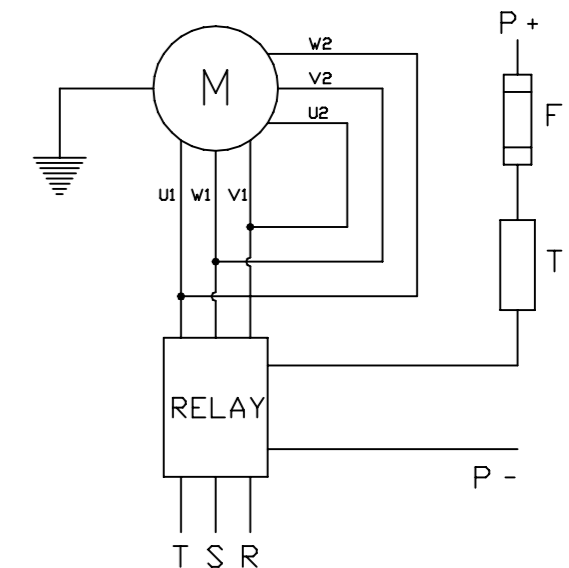

U1 - NERO / BLACK  
U2 - VERDE / GREEN  
V1 - AZZURRO / BLUE  
V2 - BIANCO / WHITE  
W1 - MARRONE / BROWN  
W2 - GIALLO / YELLOW  
T - TERMOSTATO / THERMO SWITCH  
F - FUSIBILE / FUSE  
P - ALIMENTAZIONE RELE' / RELAY CURRENT SUPPLY

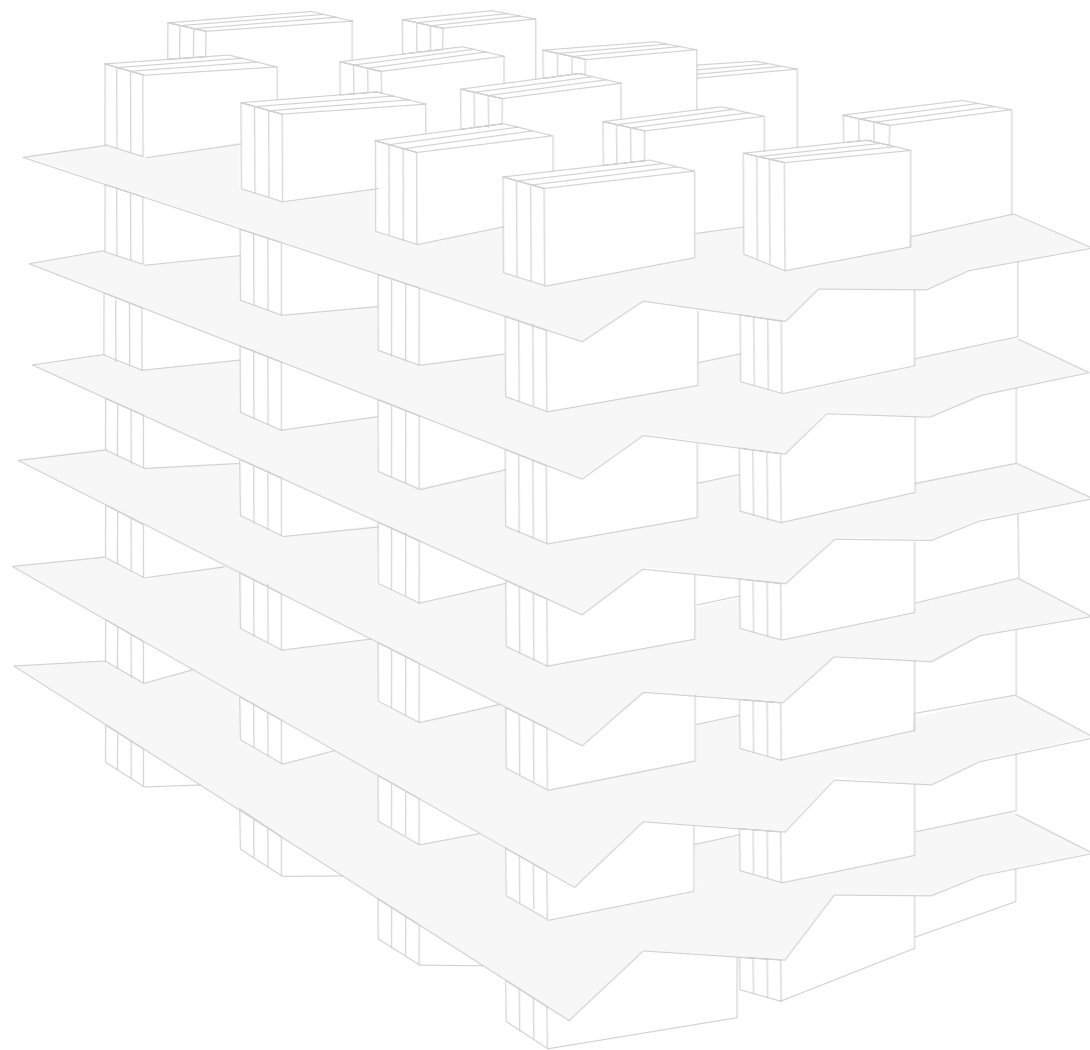
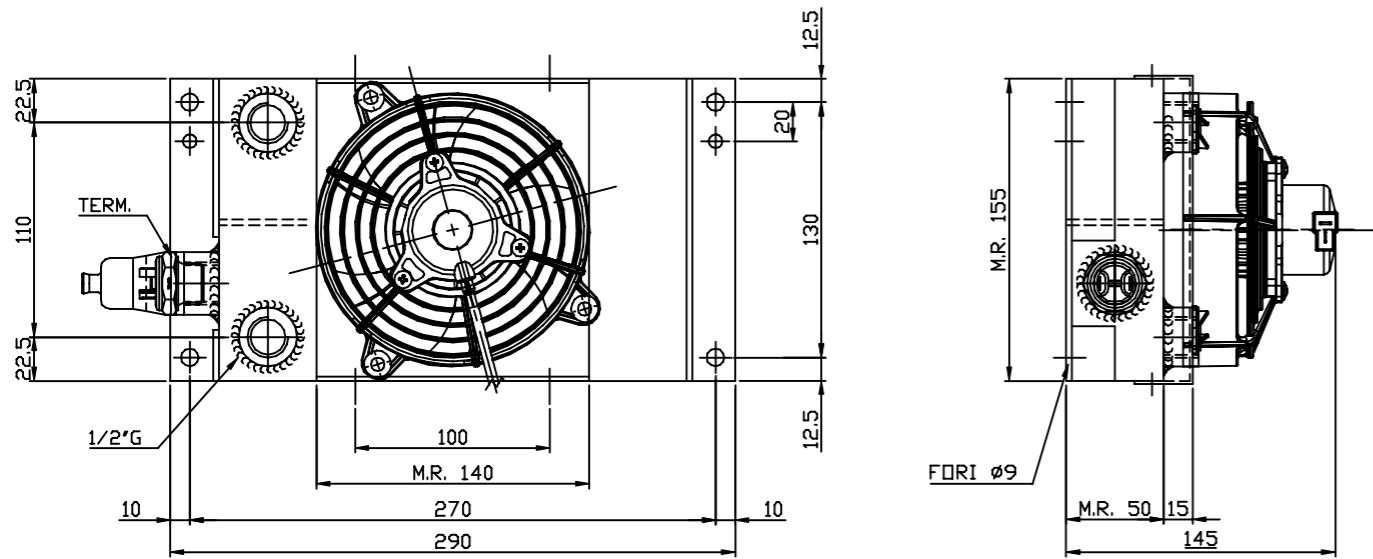

**DATI TECNICI - TECHNICAL DATA**

TENSIONE VOLTAGE	ASSORBIMENTO CURRENT	PORTATA ARIA AIR FLOW	PROTEZIONE PROTECTION	Ø
V	A	m <sup>3</sup> /h	IP	mm
12	2,65	360	66	130
24	2,65	360	66	130

**DIAGRAMMA DI RENDIMENTO - PERFORMANCE DIAGRAM**

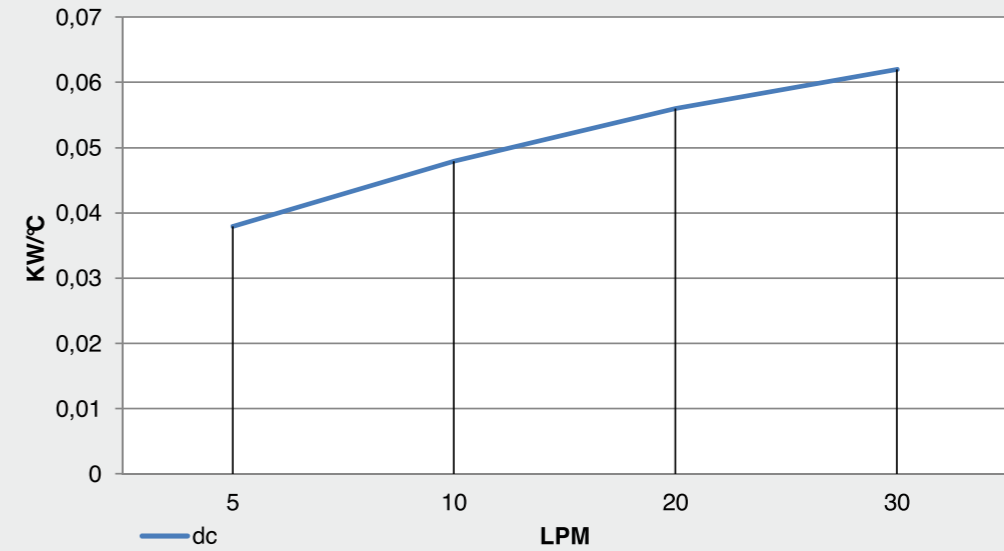

**DIAGRAMMA PERDITE DI CARICO - PRESSURE DROP DIAGRAM**

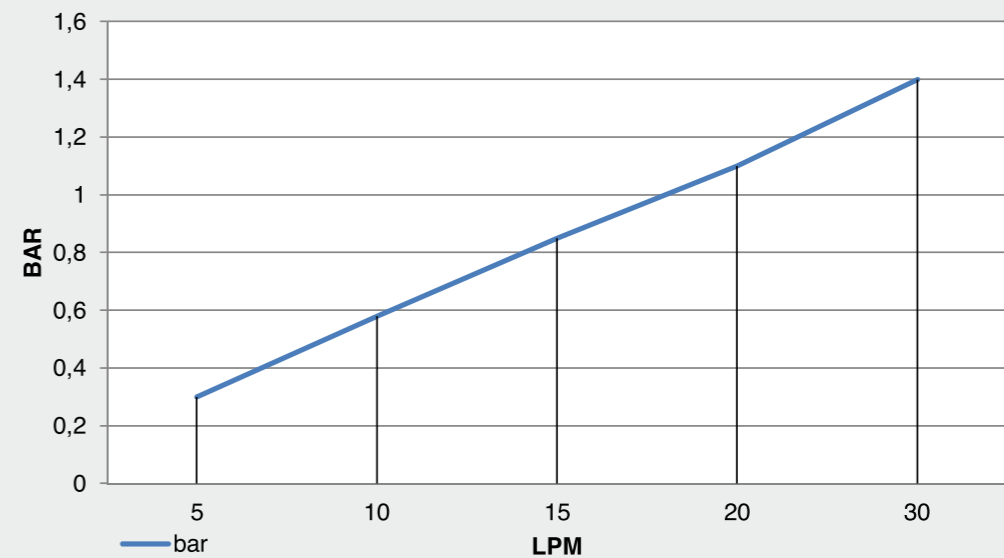

Portata olio - Oil flow: 5-30 lt/1'

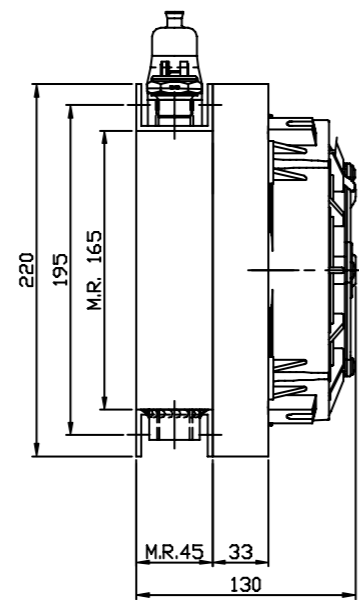
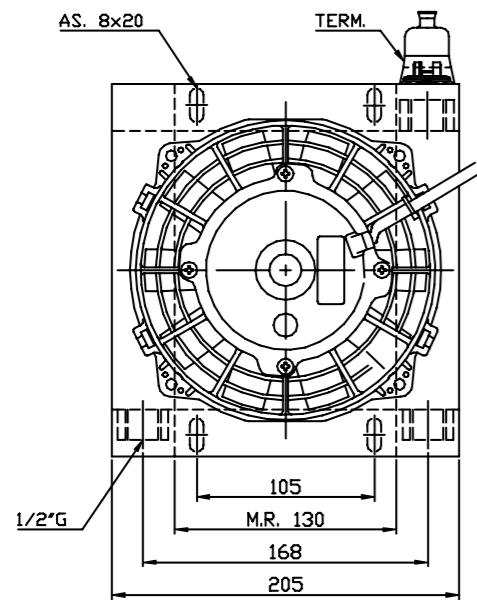

Vcc

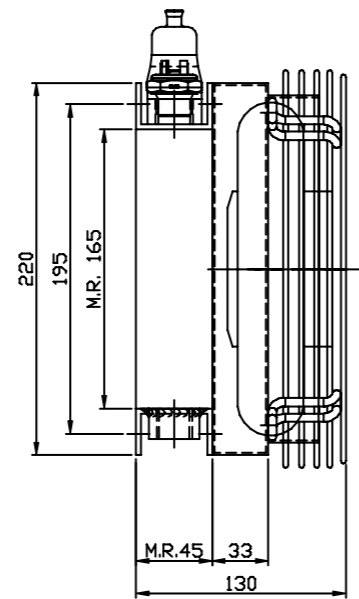
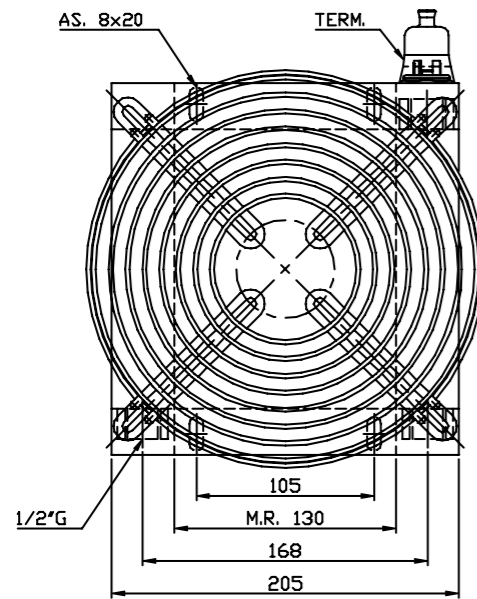

Vac

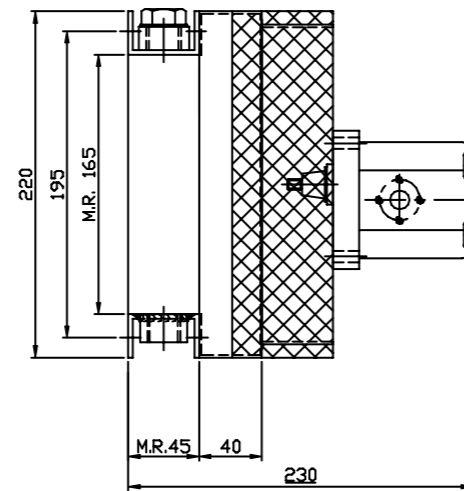
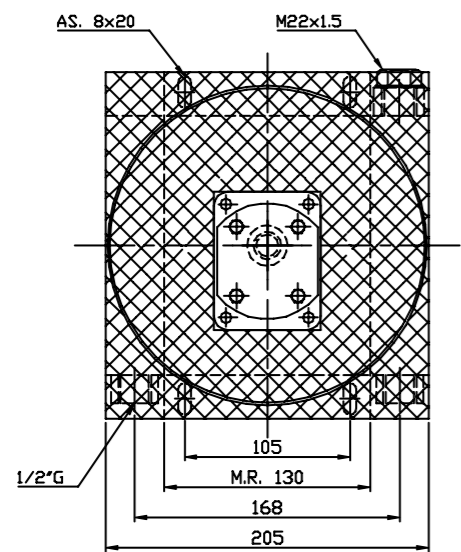

GR1

**DATI TECNICI - TECHNICAL DATA**

TENSIONE VOLTAGE	ASSORBIMENTO CURRENT	PORTATA ARIA AIR FLOW	PROTEZIONE PROTECTION	Ø
V	A	m <sup>3</sup> /h	IP	mm
12	7,7	480	68	167
24	3,7	470	68	167
230 Hz 50/60	0,30 / 0,34	890 / 990	44	200
230/400 Hz 50/60	0,29-0,17 / 0,23-0,13	890 / 990	44	200
Predisposizione GR1 - Prepared for GR1			/	190

**DIAGRAMMA DI RENDIMENTO - PERFORMANCE DIAGRAM**

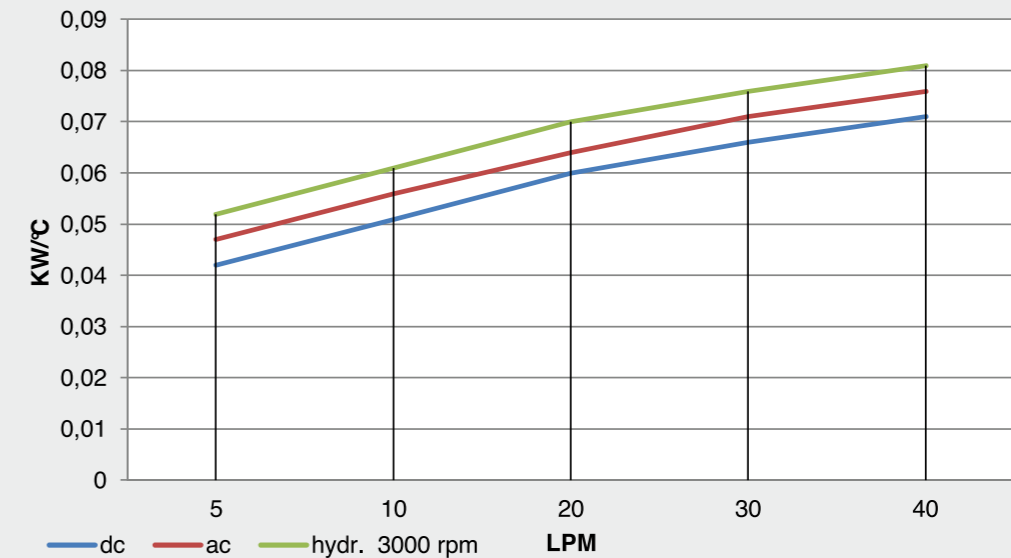

**DIAGRAMMA PERDITE DI CARICO - PRESSURE DROP DIAGRAM**

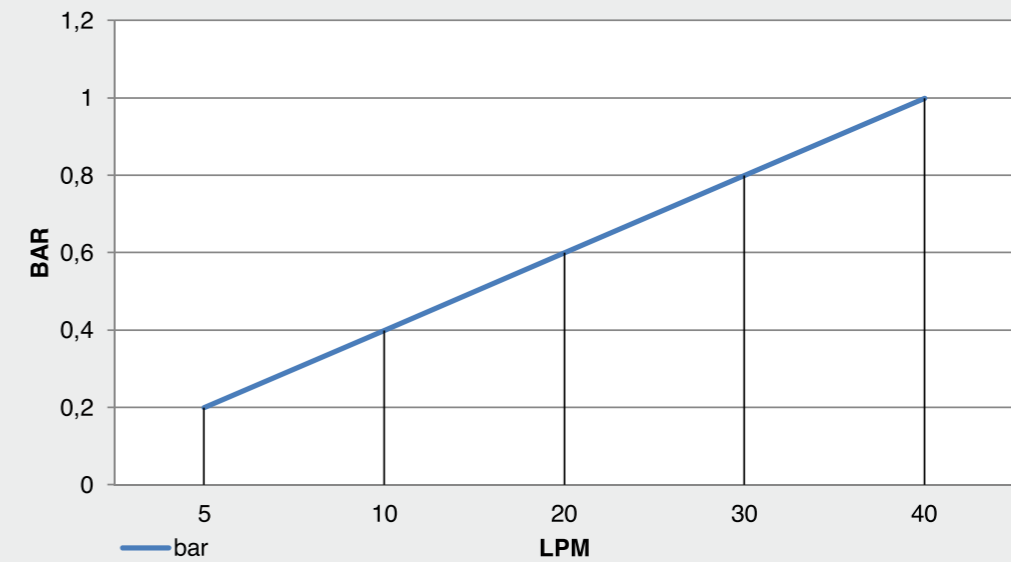

Portata olio - Oil flow: 5-40 lt/1'

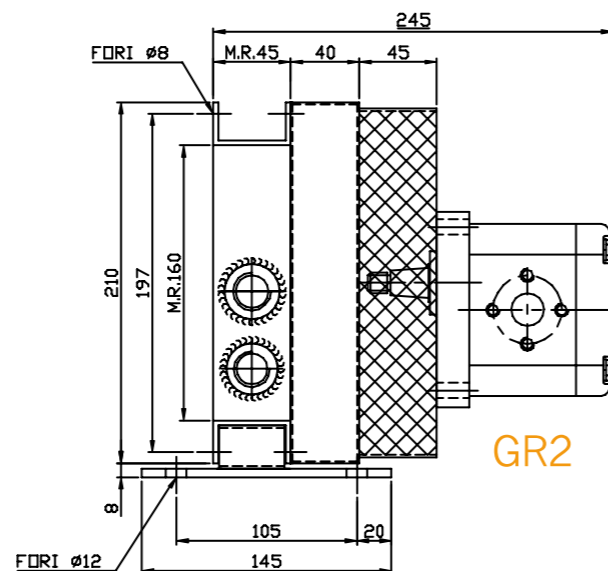
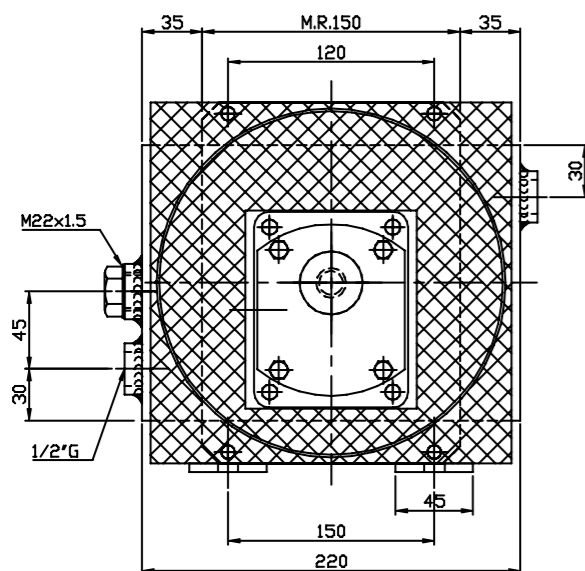
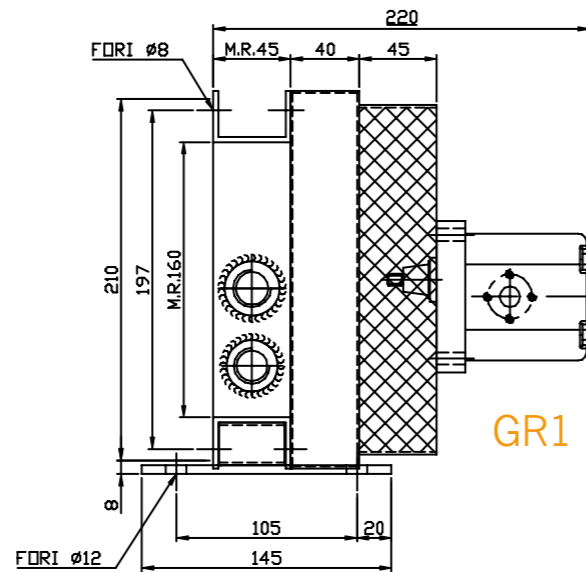
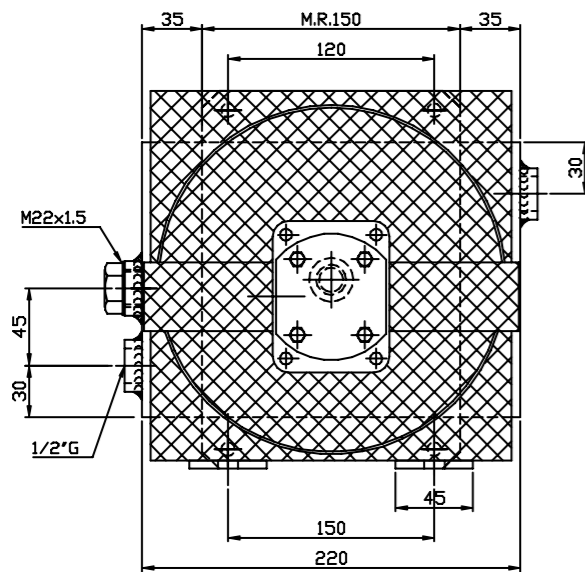
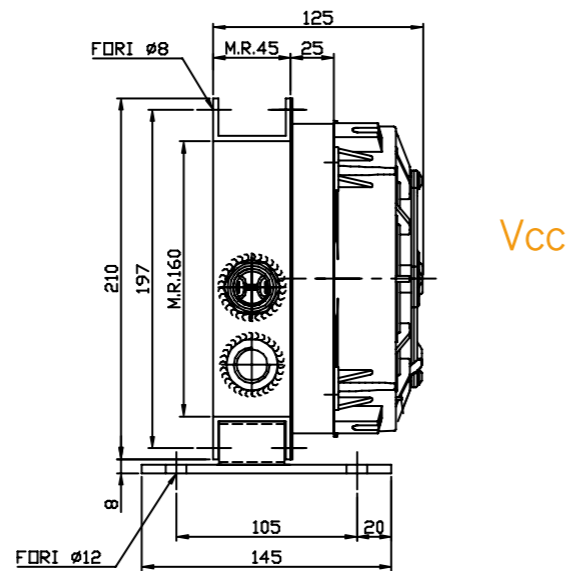
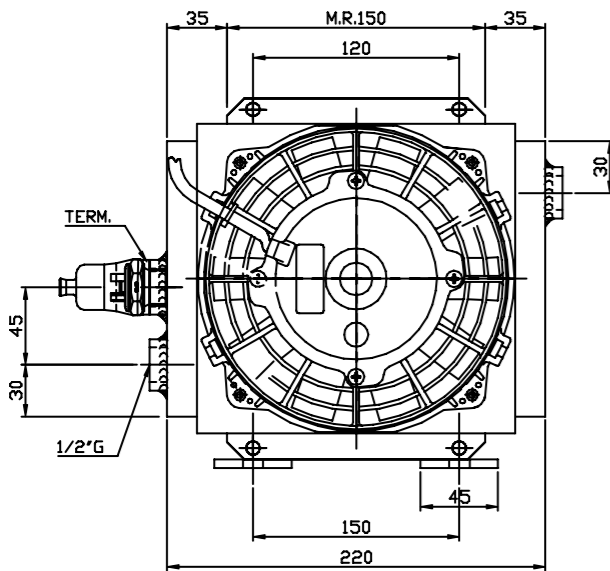

**DATI TECNICI - TECHNICAL DATA**

TENSIONE VOLTAGE	ASSORBIMENTO CURRENT	PORTATA ARIA AIR FLOW	PROTEZIONE PROTECTION	Ø
V	A	m <sup>3</sup> /h	IP	mm
12	7,7	480	68	167
24	3,7	470	68	167
Predisposizione GR1 e GR2 - Prepared for GR1 and GR2			/	190

**DIAGRAMMA DI RENDIMENTO - PERFORMANCE DIAGRAM**

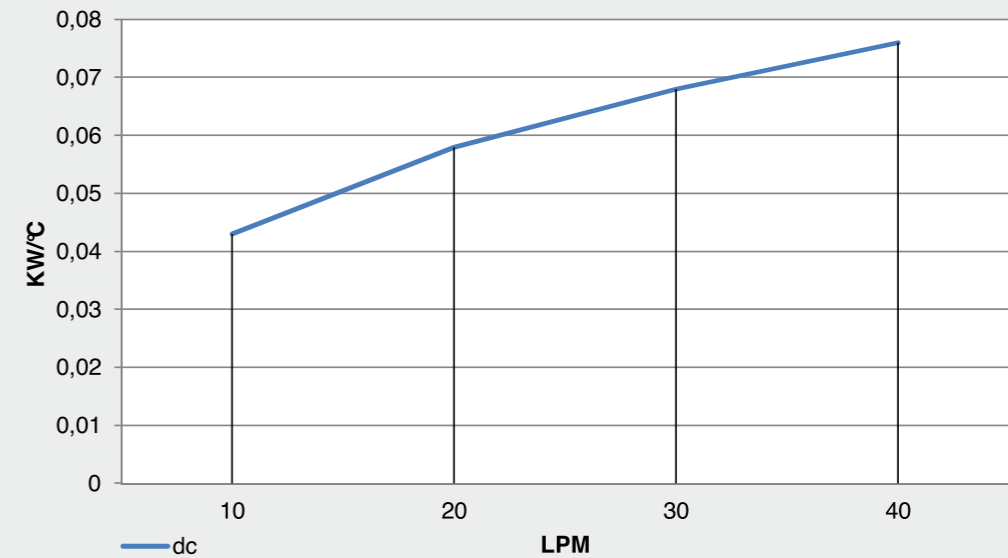

**DIAGRAMMA PERDITE DI CARICO - PRESSURE DROP DIAGRAM**

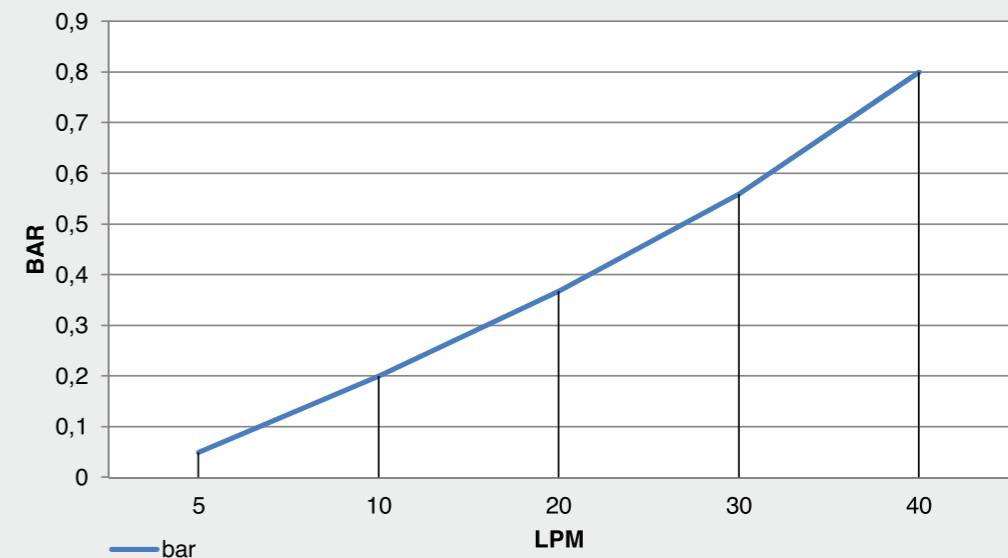

Portata olio - Oil flow: 10-40 lt/1'

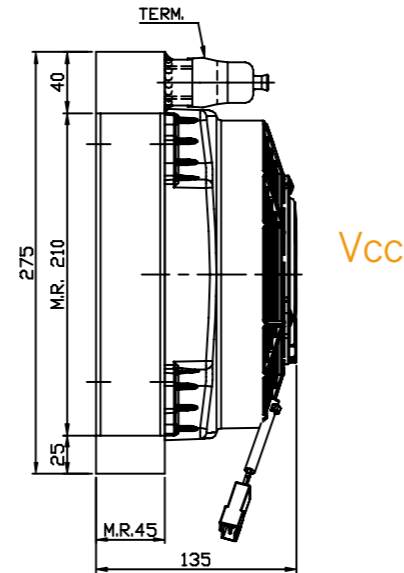
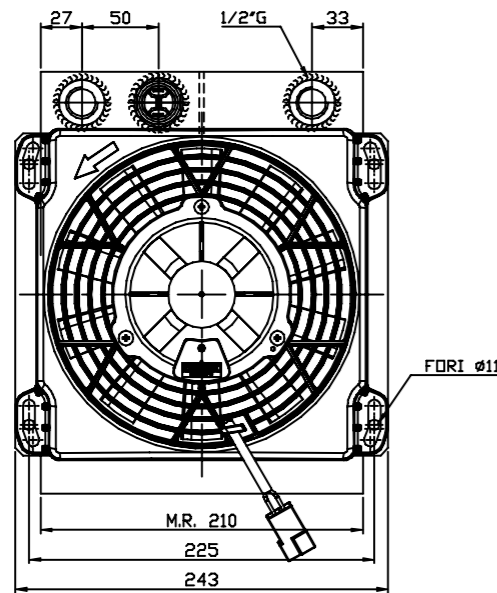

Vcc

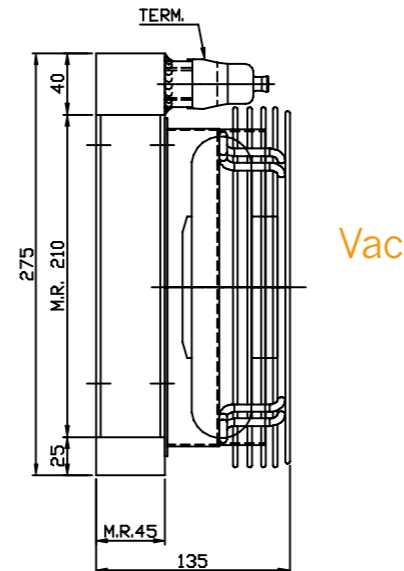
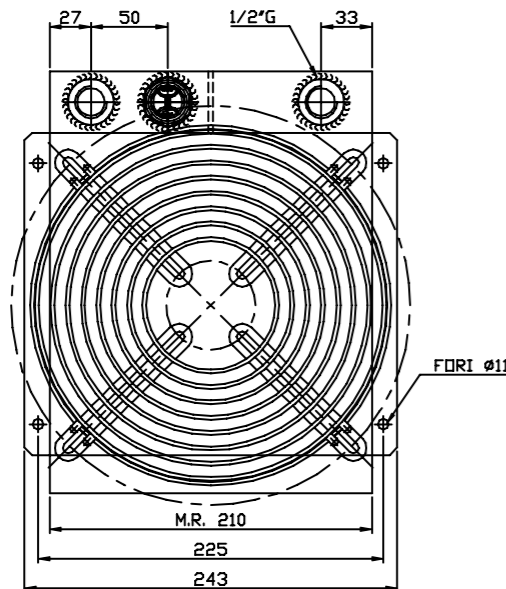

Vac

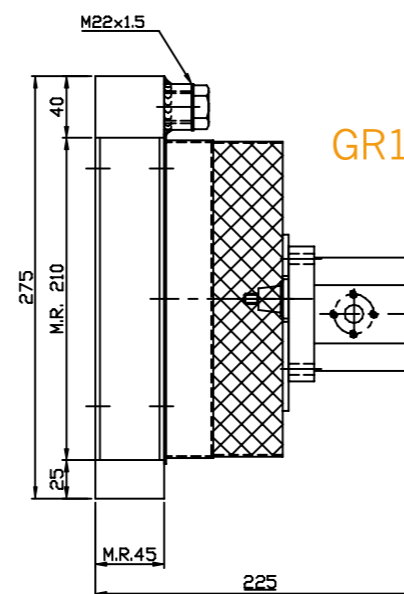
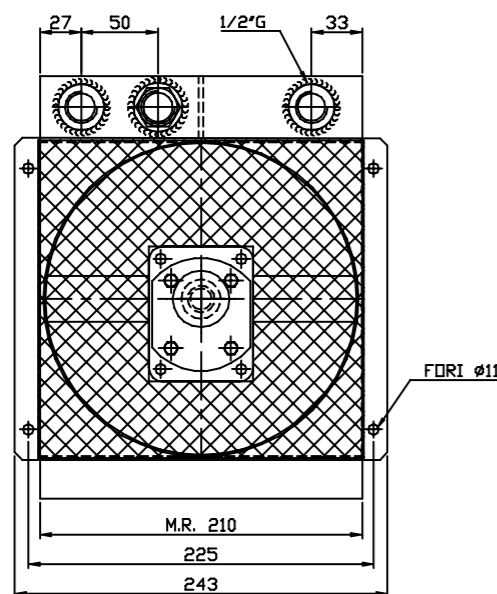

GR1

**DATI TECNICI - TECHNICAL DATA**

TENSIONE VOLTAGE	ASSORBIMENTO CURRENT	PORTATA ARIA AIR FLOW	PROTEZIONE PROTECTION	Ø
V	A	m <sup>3</sup> /h	IP	mm
12	6,2	630	68	190
24	3,1	630	68	190
230 Hz 50/60	0,30 / 0,34	890 / 990	44	200
230/400 Hz 50/60	0,29-0,17 / 0,23-0,13	890 / 990	44	200
Predisposizione GR1 - Prepared for GR1				190

**DIAGRAMMA DI RENDIMENTO - PERFORMANCE DIAGRAM**

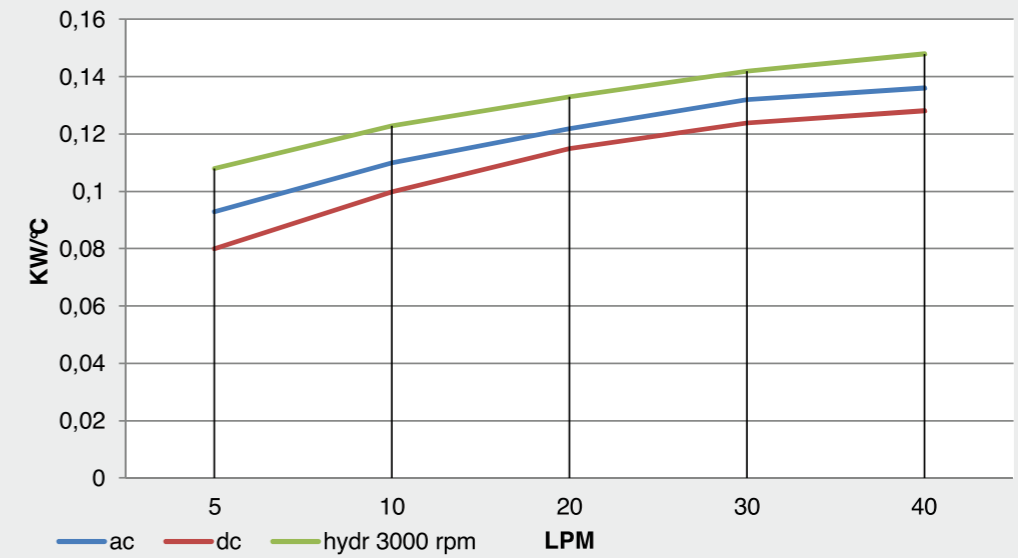

**DIAGRAMMA PERDITE DI CARICO - PRESSURE DROP DIAGRAM**

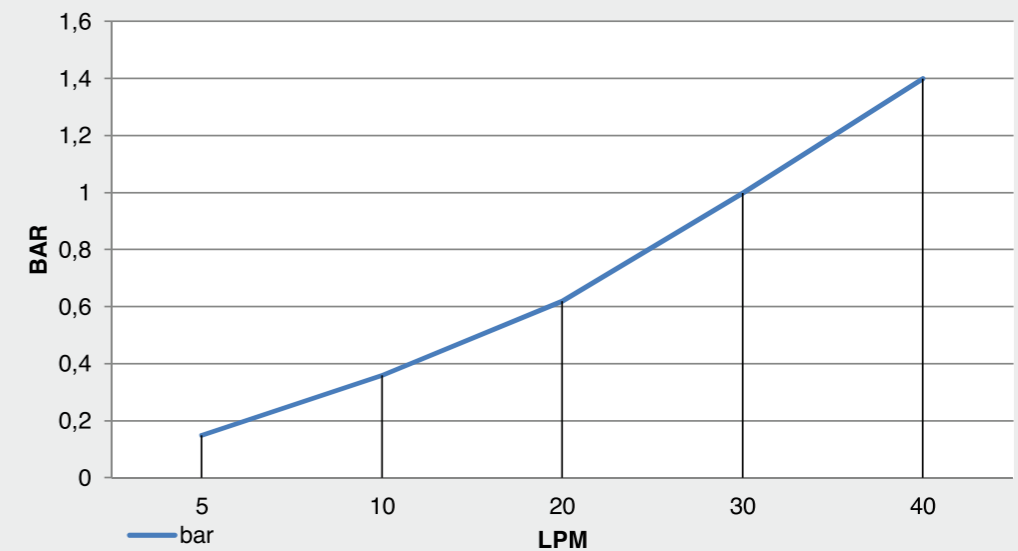

Portata olio - Oil flow: 5-40 lt/1'



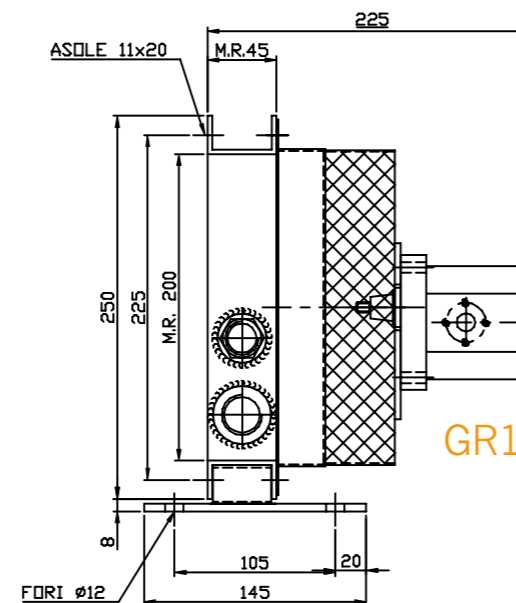
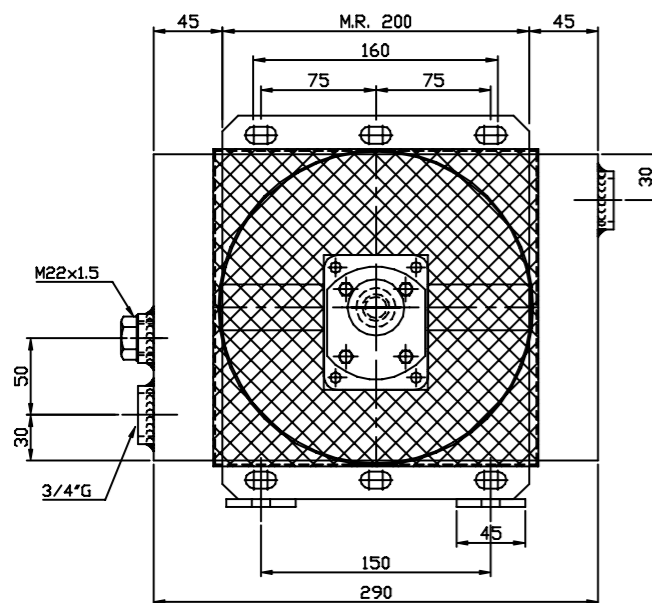
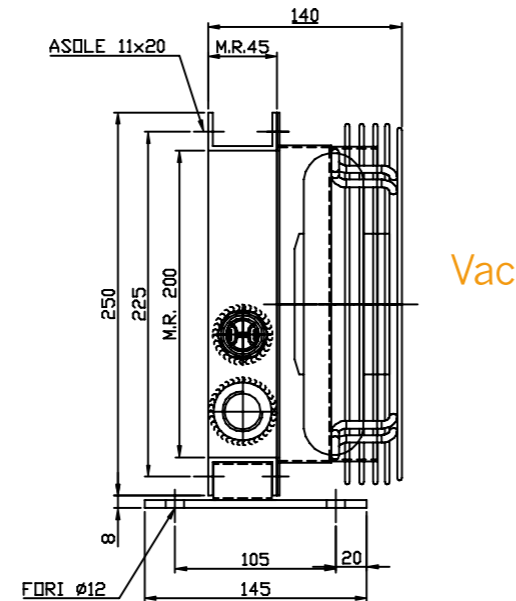
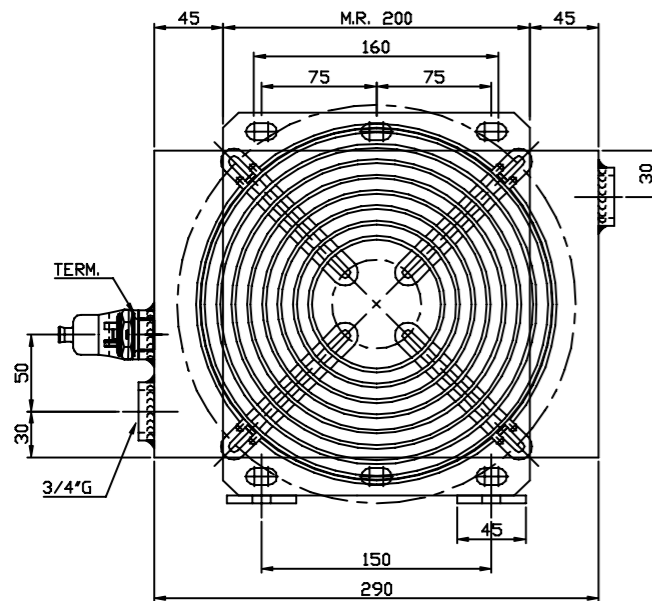
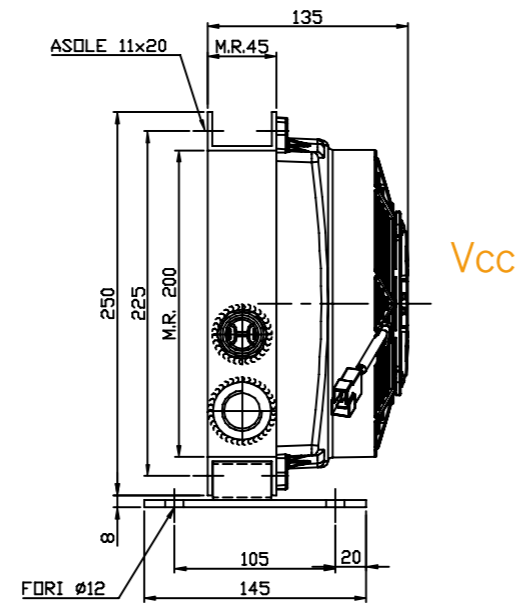
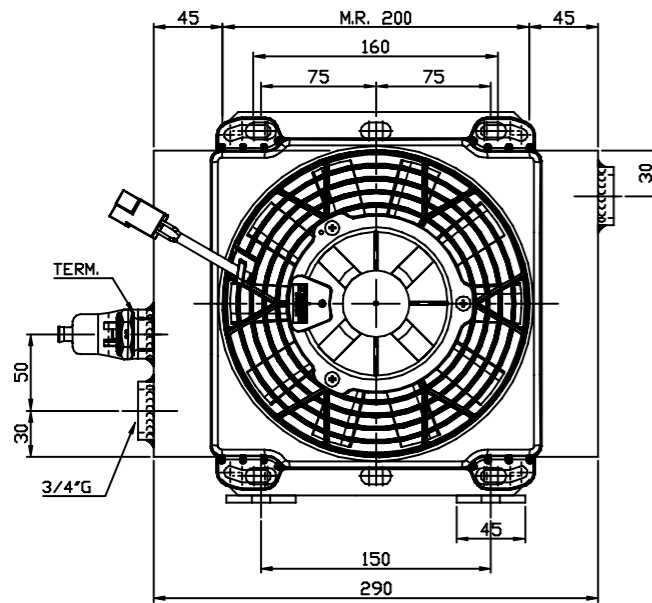

**DATI TECNICI - TECHNICAL DATA**

TENSIONE VOLTAGE	ASSORBIMENTO CURRENT	PORTATA ARIA AIR FLOW	PROTEZIONE PROTECTION	Ø
V	A	m <sup>3</sup> /h	IP	mm
12	6,2	630	68	190
24	3,1	630	68	190
230 Hz 50/60	0,30 / 0,34	890 / 990	44	200
230/400 Hz 50/60	0,29-0,17 / 0,23-0,13	890 / 990	44	200
Predisposizione GR1 - Prepared for GR1			/	190

**DIAGRAMMA DI RENDIMENTO - PERFORMANCE DIAGRAM**

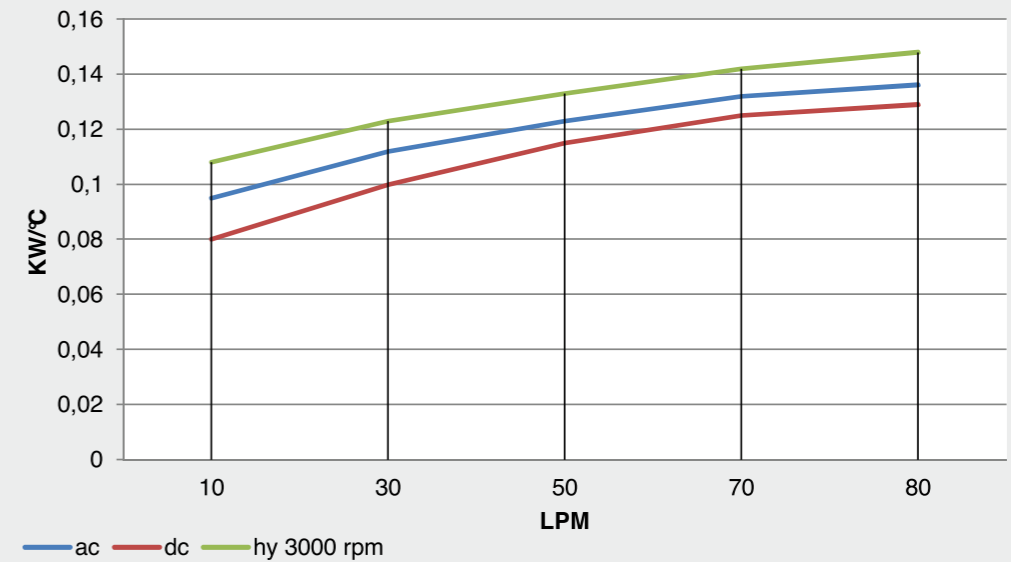

**DIAGRAMMA PERDITE DI CARICO - PRESSURE DROP DIAGRAM**

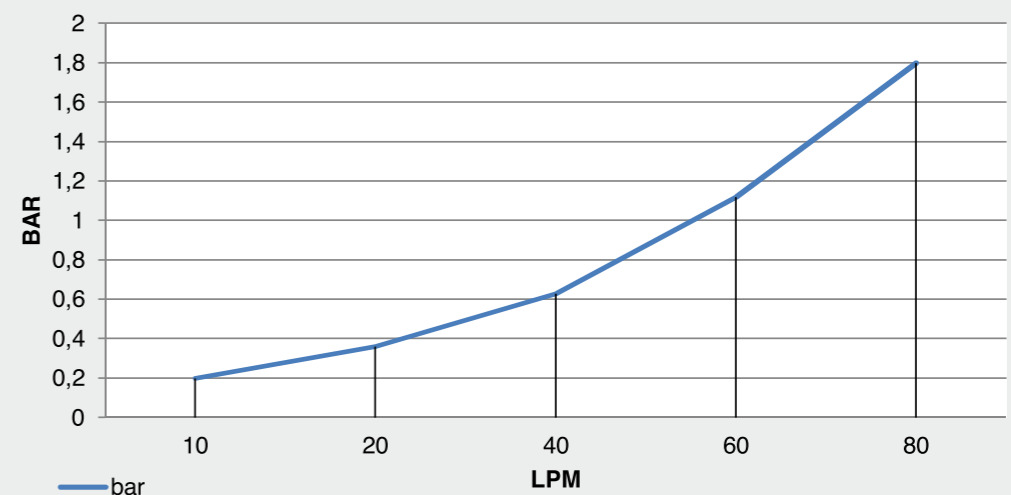

Portata olio - Oil flow: 10-80 lt/1'

Predisposizione per by-pass interno - Prepared for internal by-pass

Predisposizione per by-pass interno - Prepared for internal by-pass

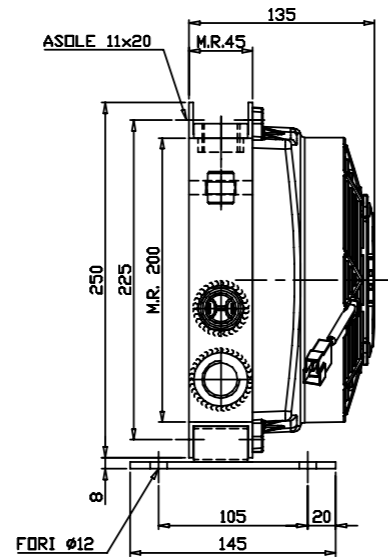
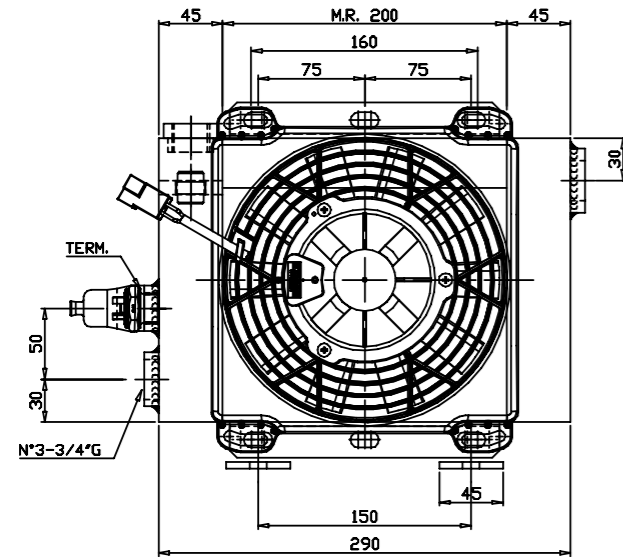

Vcc

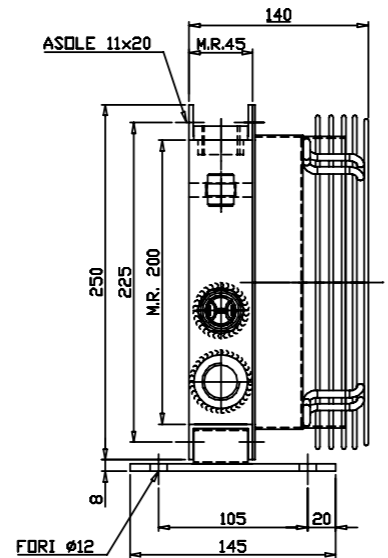
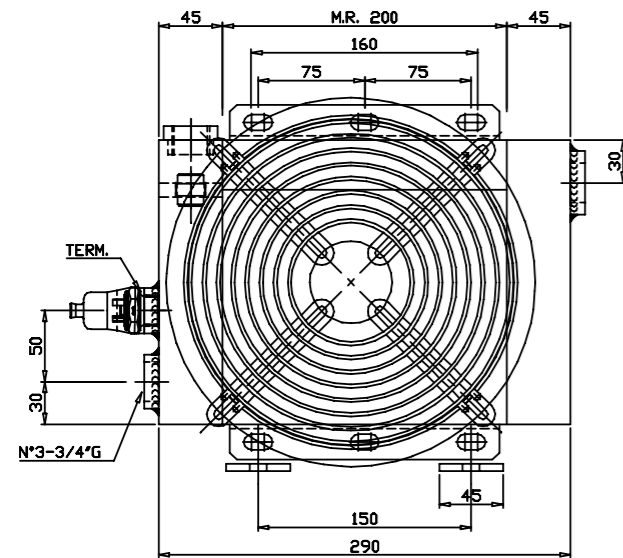

Vac

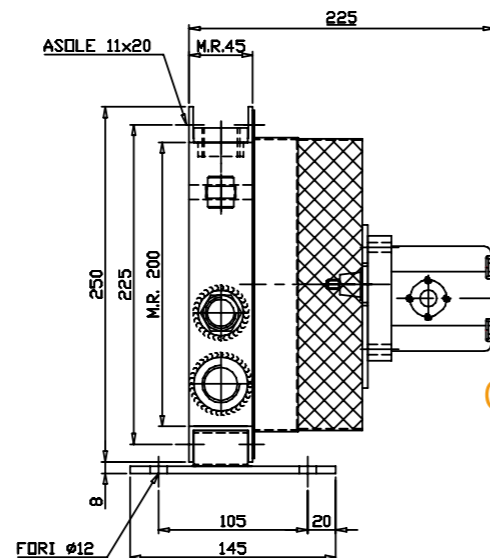
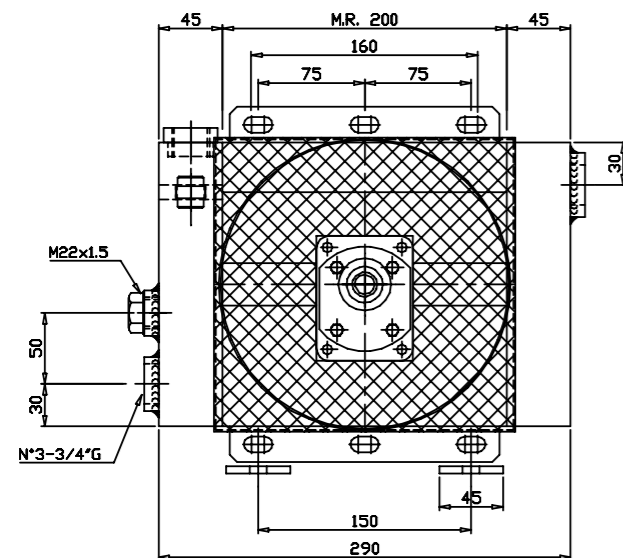

GR1

DATI TECNICI - TECHNICAL DATA

TENSIONE VOLTAGE	ASSORBIMENTO CURRENT	PORTATA ARIA AIR FLOW	PROTEZIONE PROTECTION	Ø
V	A	m <sup>3</sup> /h	IP	mm
12	6,2	630	68	190
24	3,1	630	68	190
230 Hz 50/60	0,30 / 0,34	890 / 990	44	200
230/400 Hz 50/60	0,29-0,17 / 0,23-0,13	890 / 990	44	200
Predisposizione GR1 - Prepared for GR1				190

DIAGRAMMA DI RENDIMENTO - PERFORMANCE DIAGRAM



DIAGRAMMA PERDITE DI CARICO - PRESSURE DROP DIAGRAM



Portata olio - Oil flow: 10-80 lt/1'

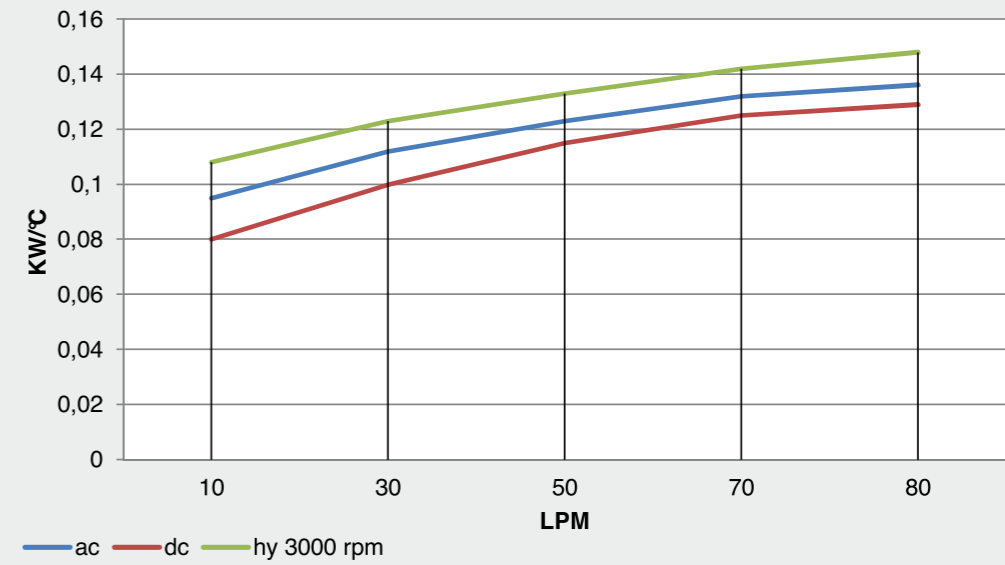
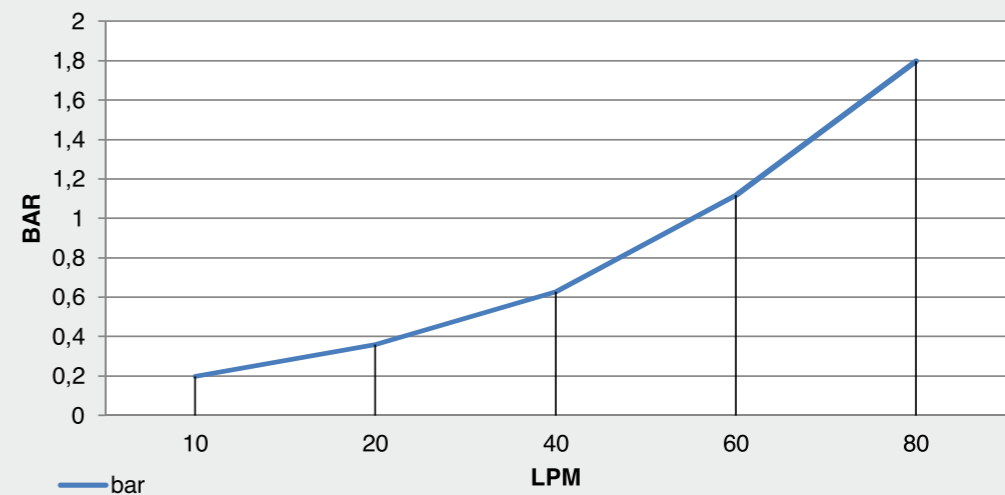
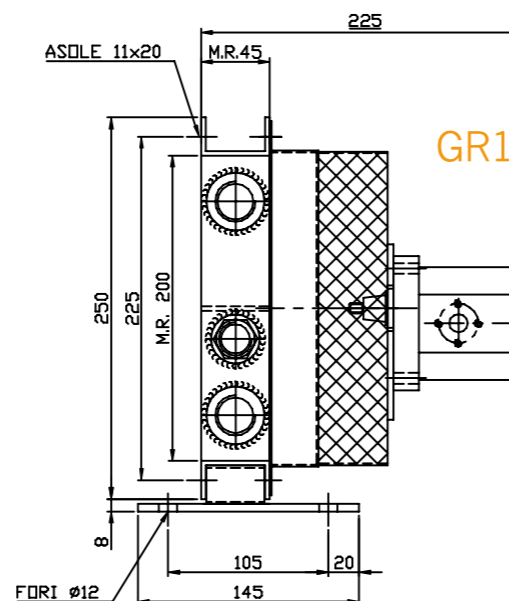
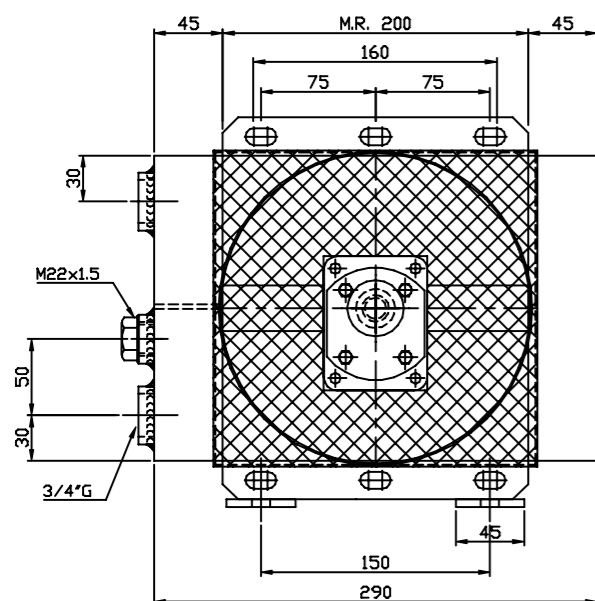
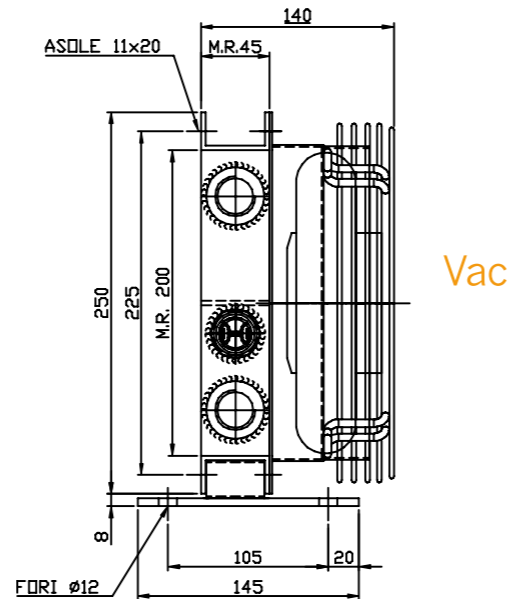
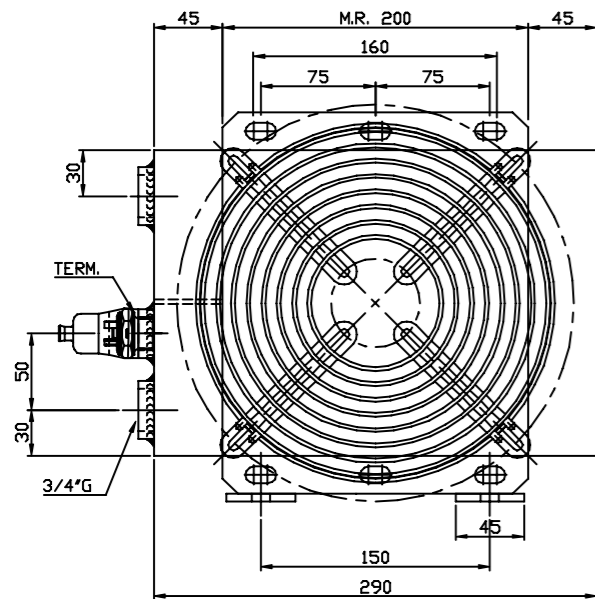
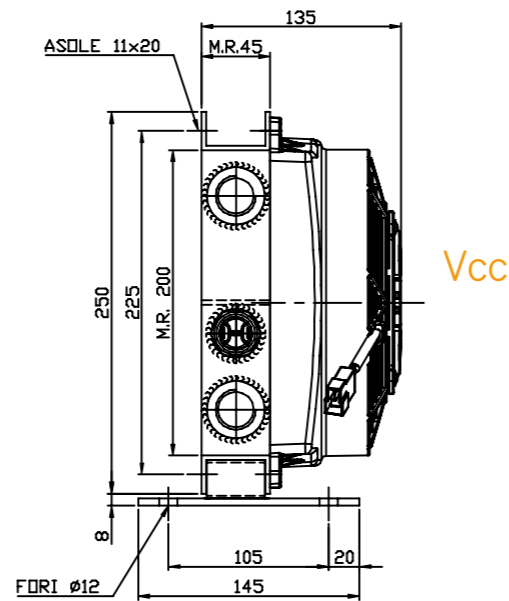
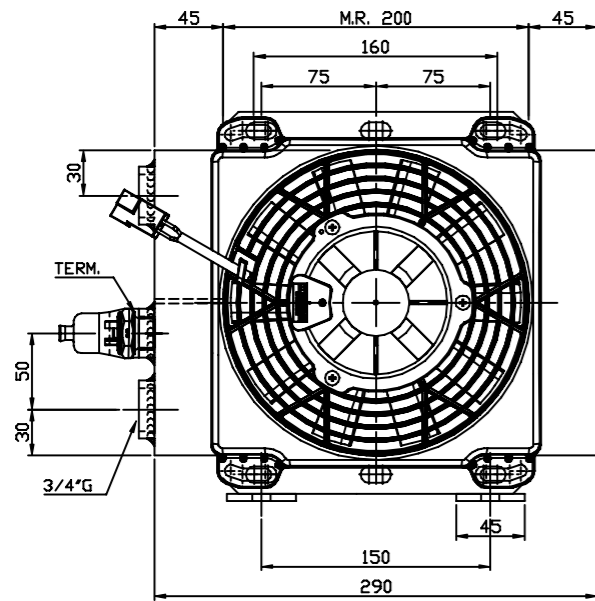

**DATI TECNICI - TECHNICAL DATA**

TENSIONE VOLTAGE	ASSORBIMENTO CURRENT	PORTATA ARIA AIR FLOW	PROTEZIONE PROTECTION	Ø
V	A	m <sup>3</sup> /h	IP	mm
12	6,2	630	68	190
24	3,1	630	68	190
230 Hz 50/60	0,30 / 0,34	890 / 990	44	200
230/400 Hz 50/60	0,29-0,17 / 0,23-0,13	890 / 990	44	200
Predisposizione GR1 - Prepared for GR1				190

**DIAGRAMMA DI RENDIMENTO - PERFORMANCE DIAGRAM**

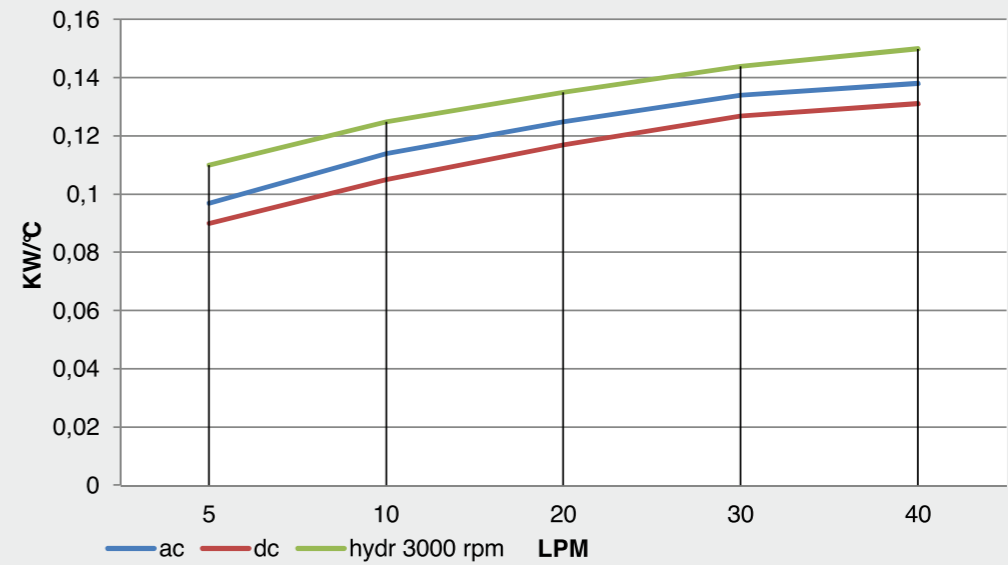

**DIAGRAMMA PERDITE DI CARICO - PRESSURE DROP DIAGRAM**

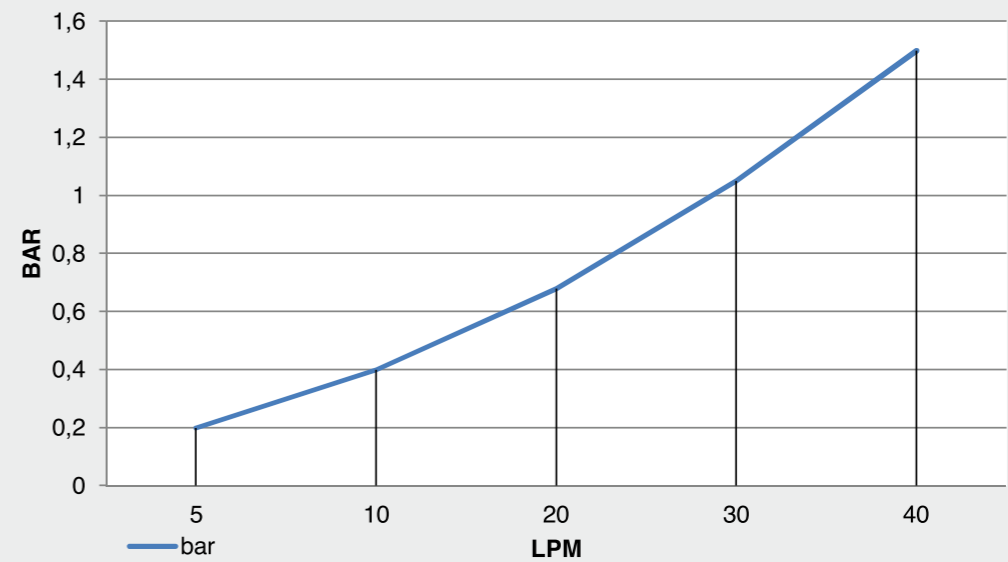

Portata olio - Oil flow: 5-40 lt/1'

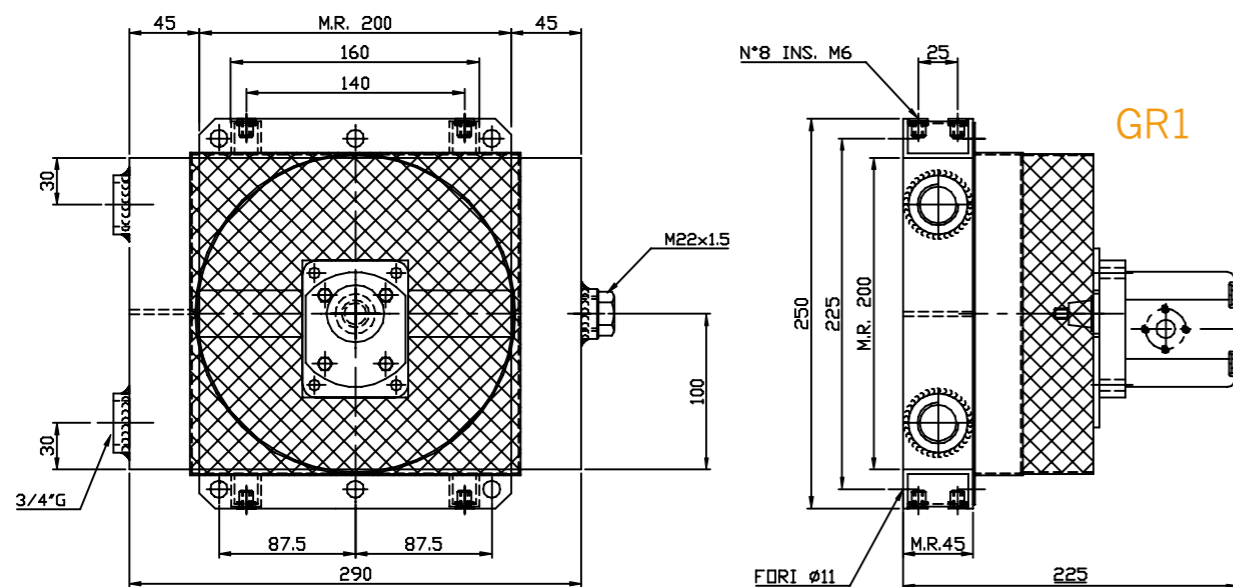
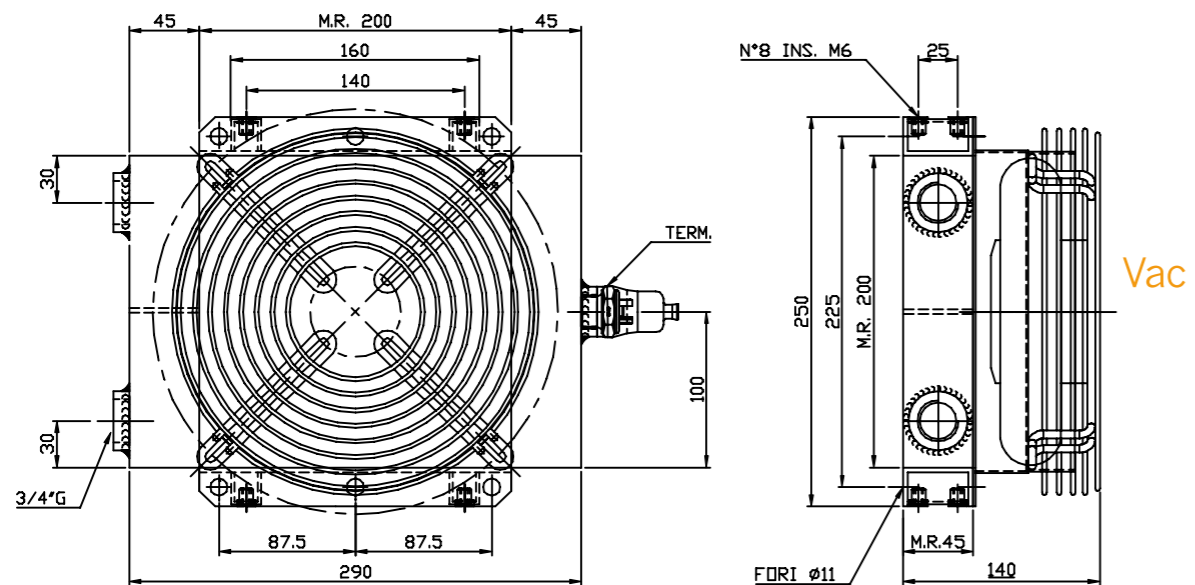
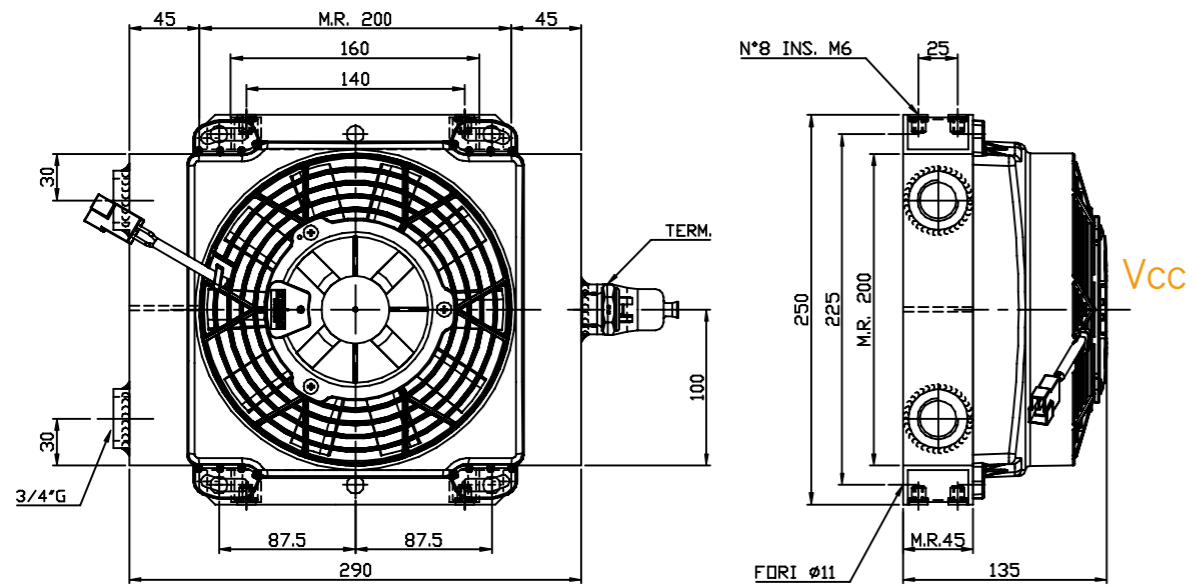

**DATI TECNICI - TECHNICAL DATA**

TENSIONE VOLTAGE	ASSORBIMENTO CURRENT	PORTATA ARIA AIR FLOW	PROTEZIONE PROTECTION	Ø
V	A	m <sup>3</sup> /h	IP	mm
12	6,2	630	68	190
24	3,1	630	68	190
230 Hz 50/60	0,30 / 0,34	890 / 990	44	200
230/400 Hz 50/60	0,29-0,17 / 0,23-0,13	890 / 990	44	200
Predisposizione GR1 - Prepared for GR1			/	190

**DIAGRAMMA DI RENDIMENTO - PERFORMANCE DIAGRAM**

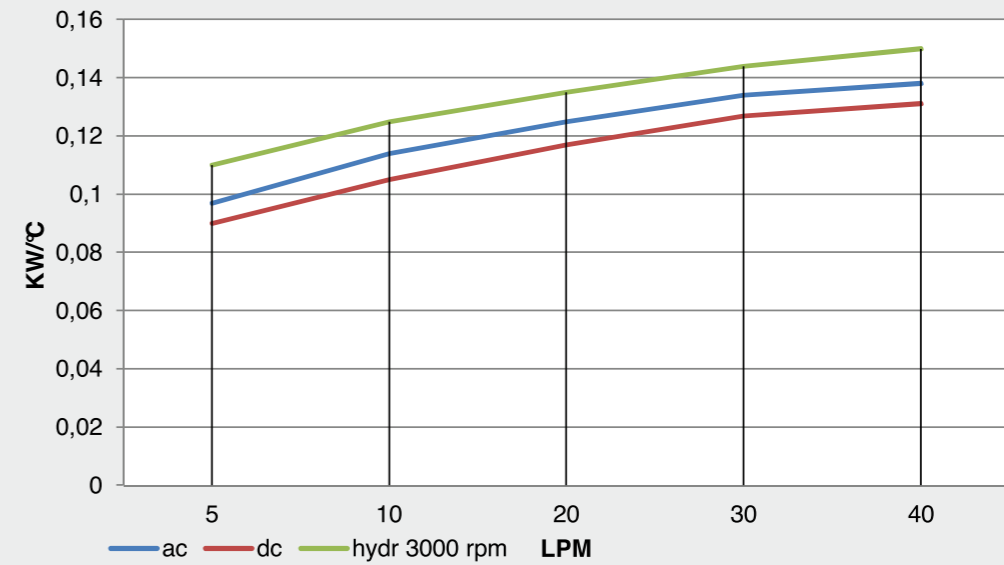

**DIAGRAMMA PERDITE DI CARICO - PRESSURE DROP DIAGRAM**

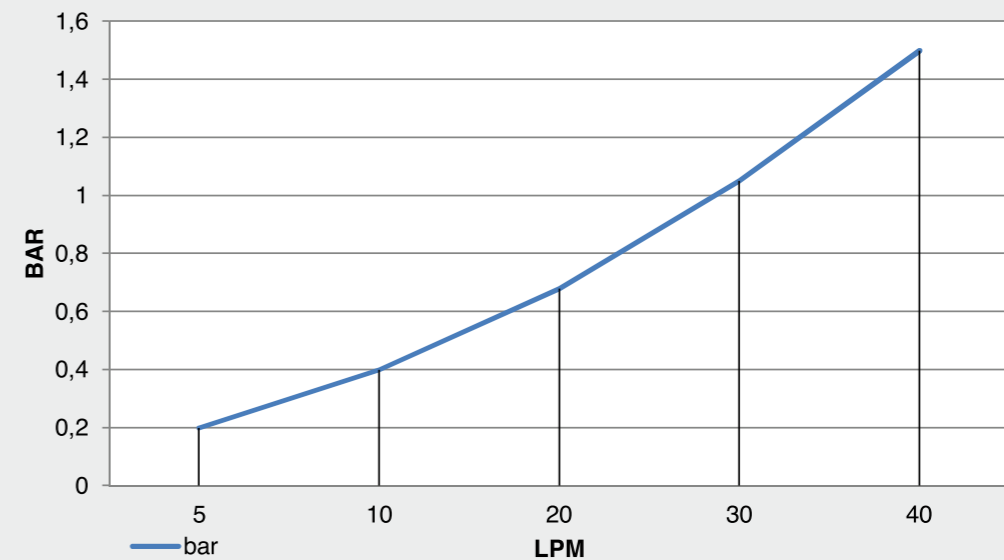

Portata olio - Oil flow: 5-40 lt/1'

**DATI TECNICI - TECHNICAL DATA**

TENSIONE VOLTAGE	ASSORBIMENTO CURRENT	PORTATA ARIA AIR FLOW	PROTEZIONE PROTECTION	Ø
V	A	m <sup>3</sup> /h	IP	mm
12	6,2	630	68	190
24	3,1	630	68	190
230 Hz 50/60	0,30 / 0,34	890 / 990	44	200
230/400 Hz 50/60	0,29-0,17 / 0,23-0,13	890 / 990	44	200
Predisposizione GR1 - Prepared for GR1			/	190

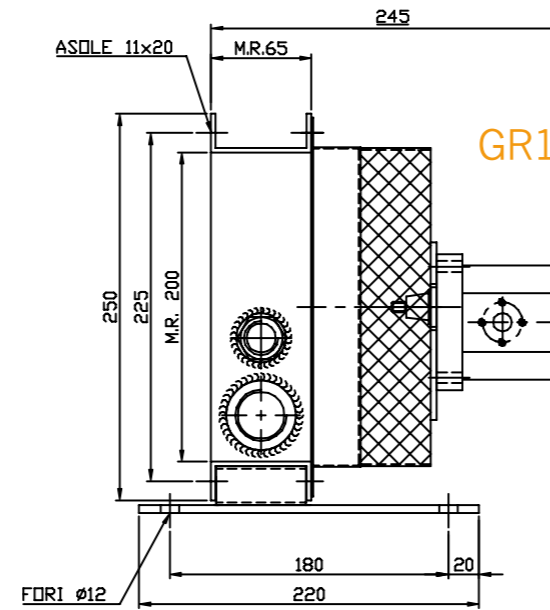
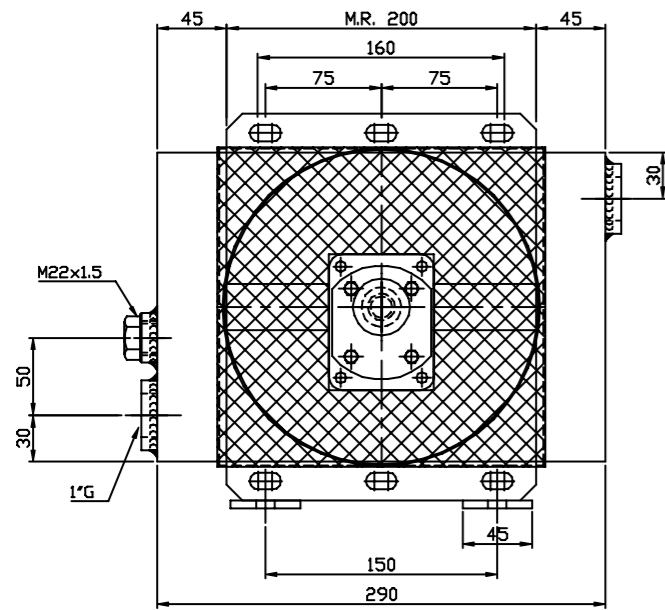
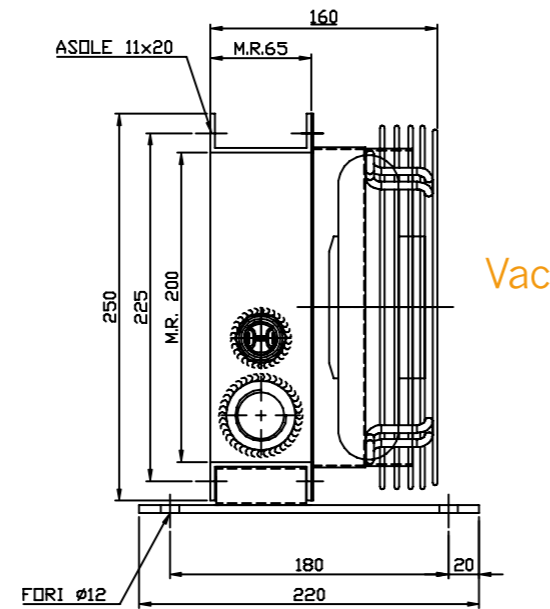
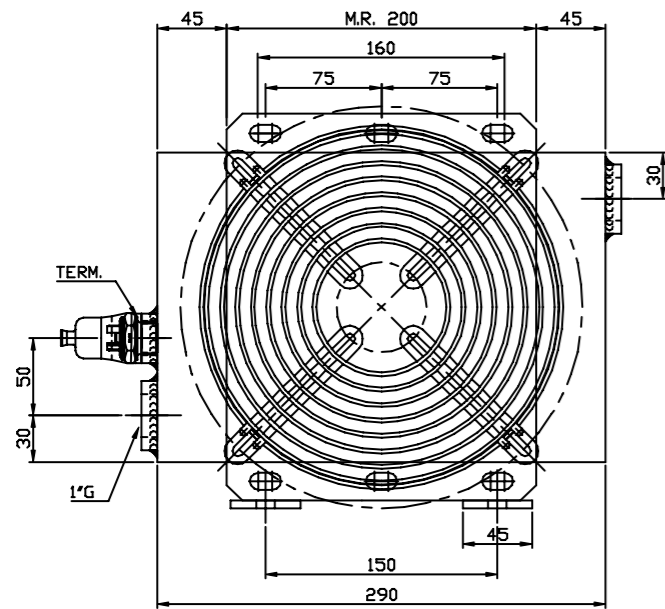
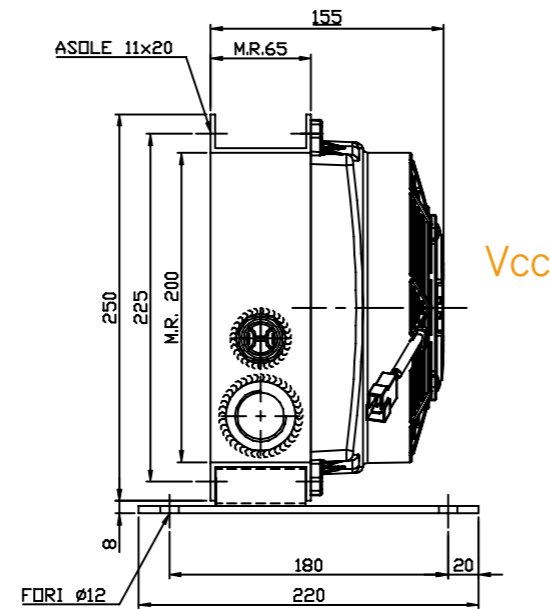
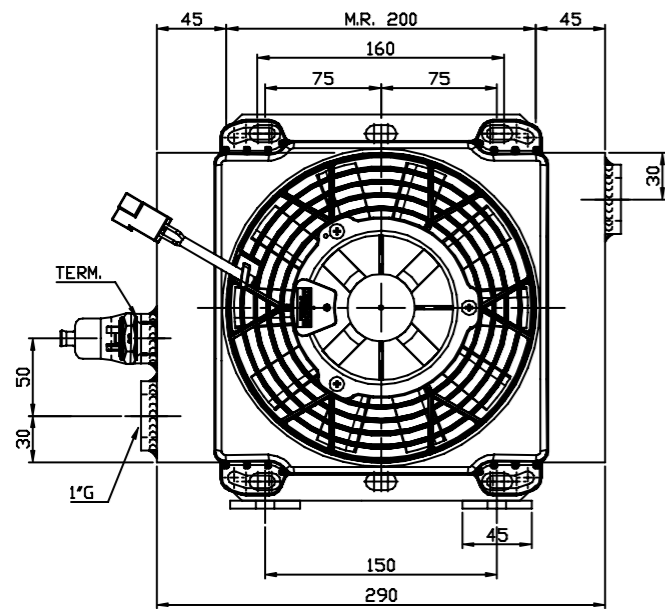

**DIAGRAMMA DI RENDIMENTO - PERFORMANCE DIAGRAM**

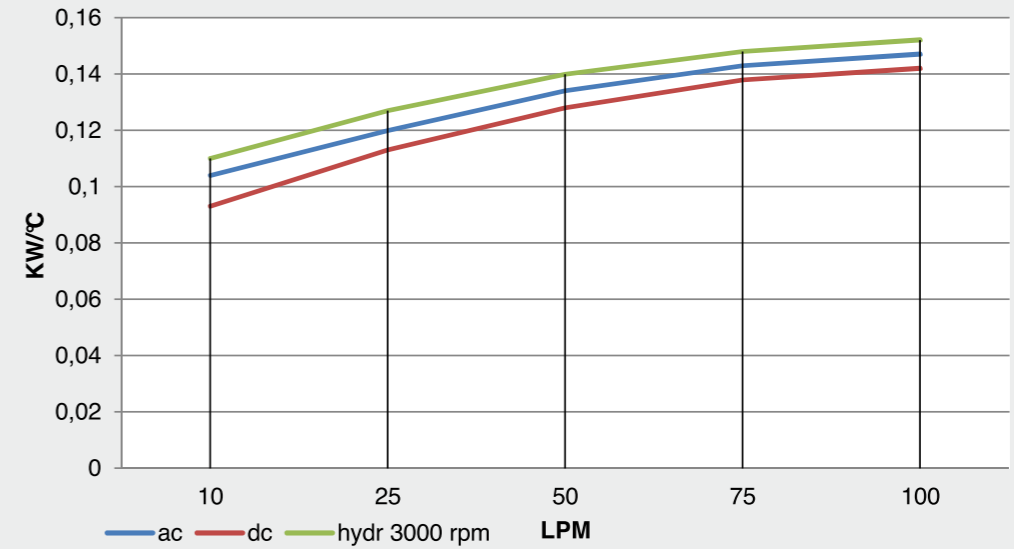

**DIAGRAMMA PERDITE DI CARICO - PRESSURE DROP DIAGRAM**

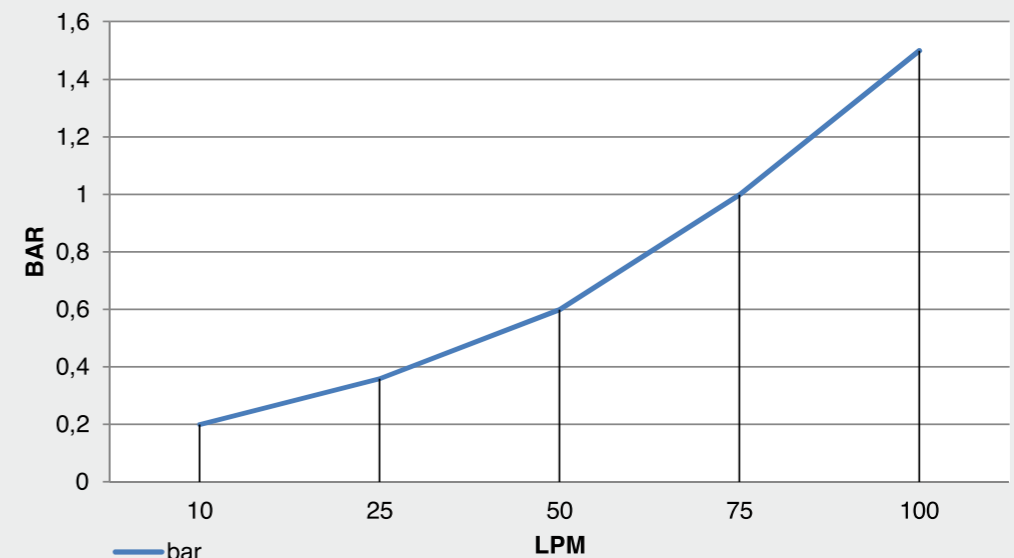

Portata olio - Oil flow: 10-100 lt/1'

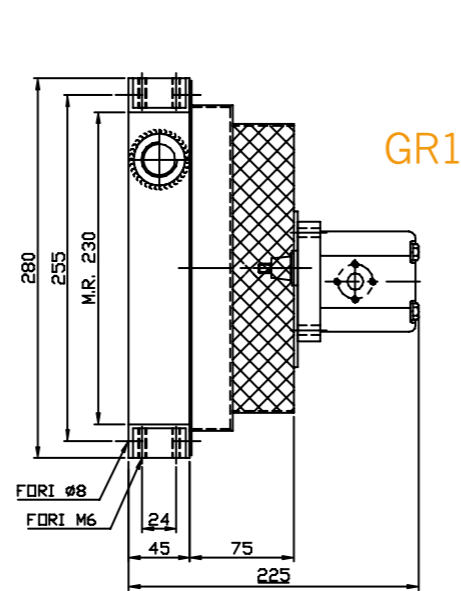
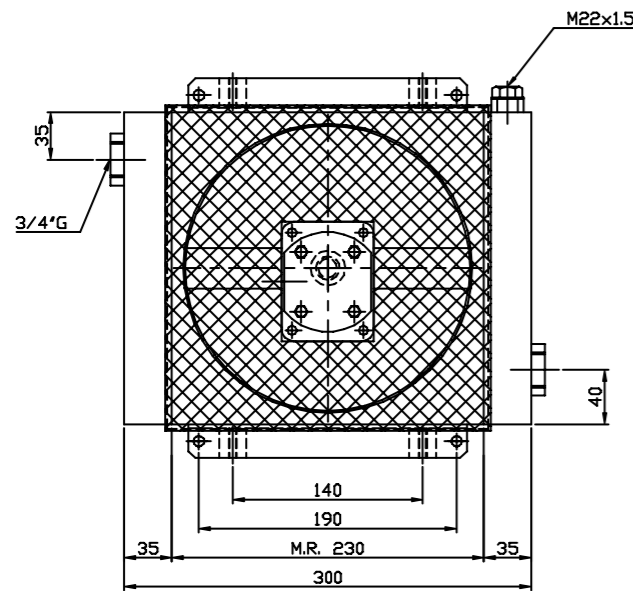
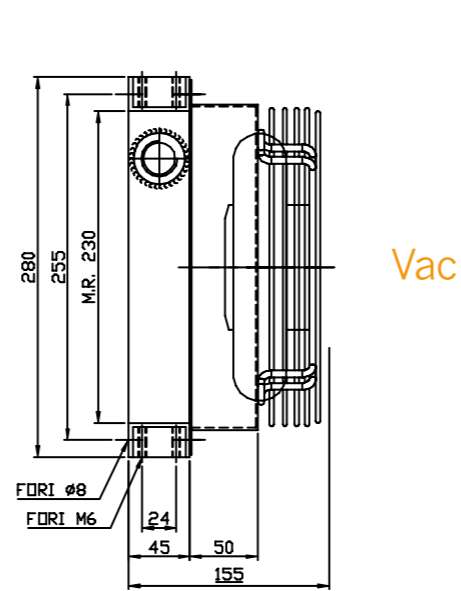
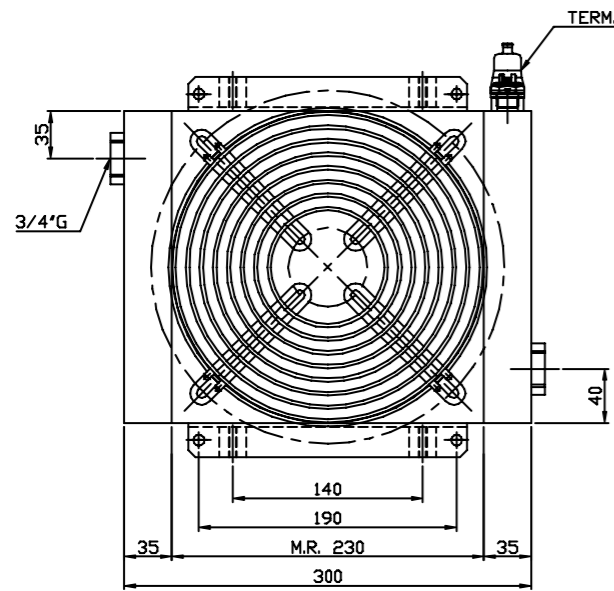
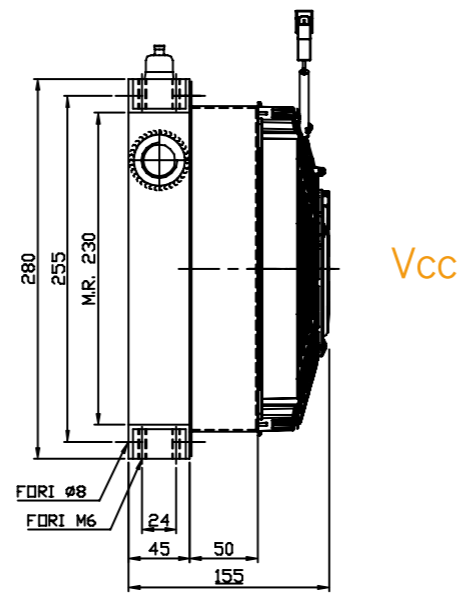
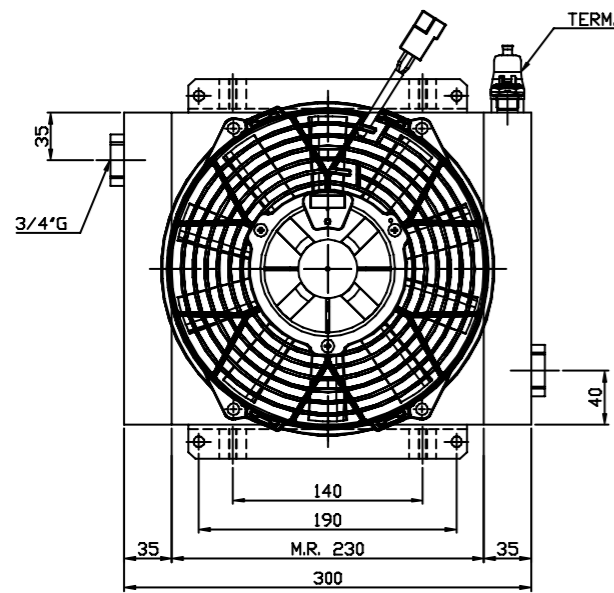

**DATI TECNICI - TECHNICAL DATA**

TENSIONE VOLTAGE	ASSORBIMENTO CURRENT	PORTATA ARIA AIR FLOW	PROTEZIONE PROTECTION	Ø
V	A	m <sup>3</sup> /h	IP	mm
12	7,7	1010	68	225
24	4,3	1070	68	225
230 Hz 50/60	0,30 / 0,34	890 / 990	44	200
230/400 Hz 50/60	0,17 / 0,13	890 / 990	44	200
Predisposizione GR1 - Prepared for GR1				190

**DIAGRAMMA DI RENDIMENTO - PERFORMANCE DIAGRAM**

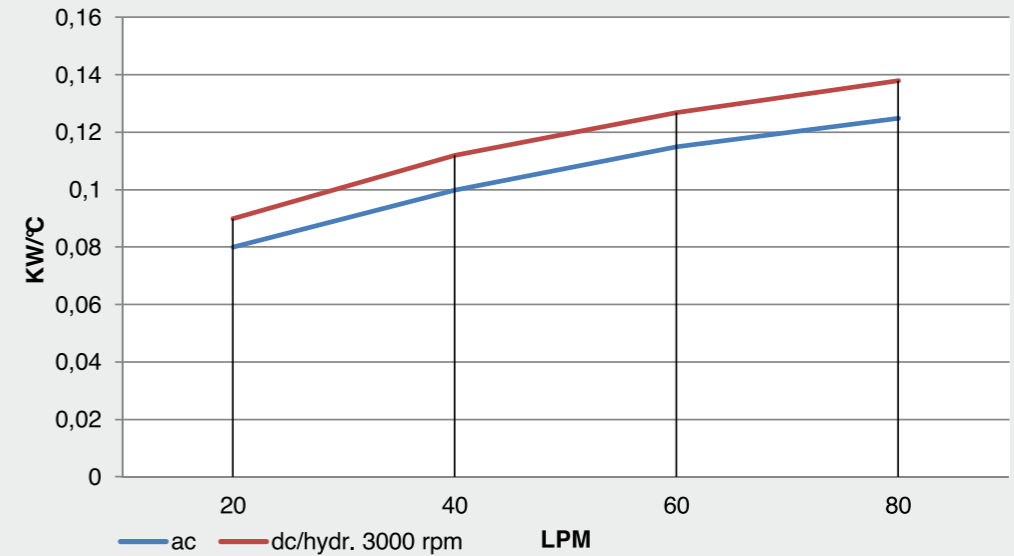

**DIAGRAMMA PERDITE DI CARICO - PRESSURE DROP DIAGRAM**

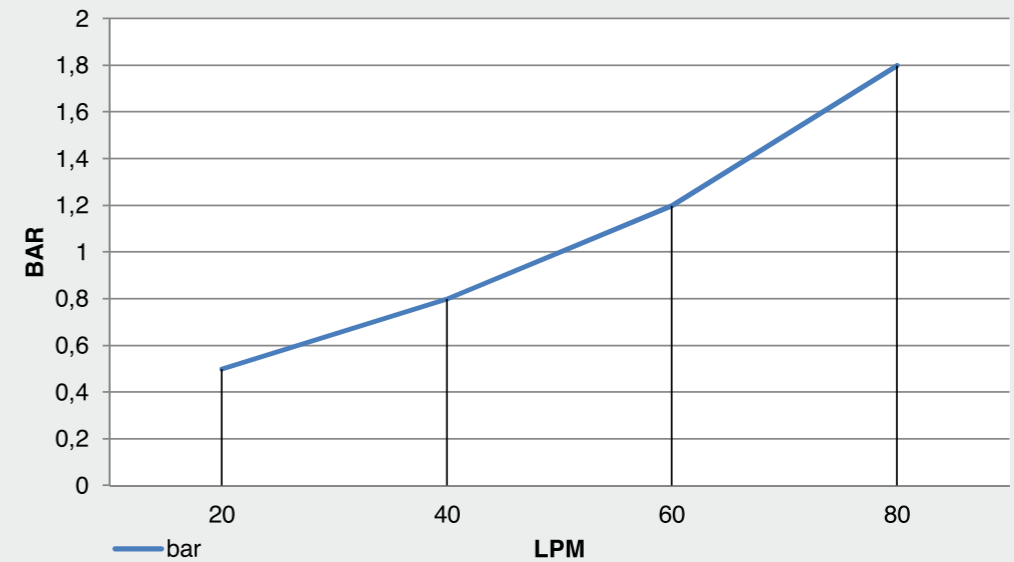

Portata olio - Oil flow: 20-80 lt/1'

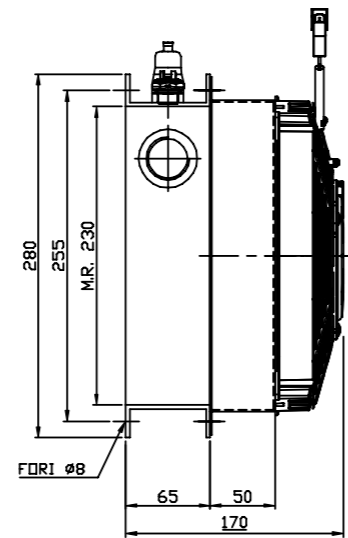
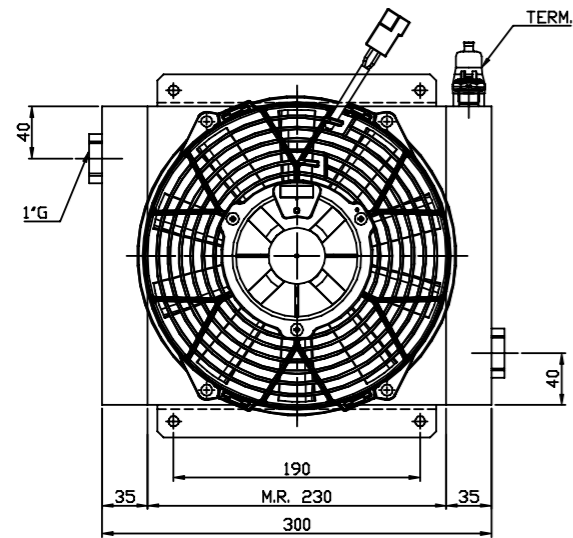

Vcc

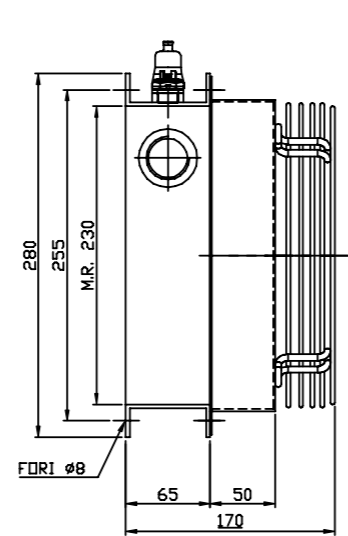
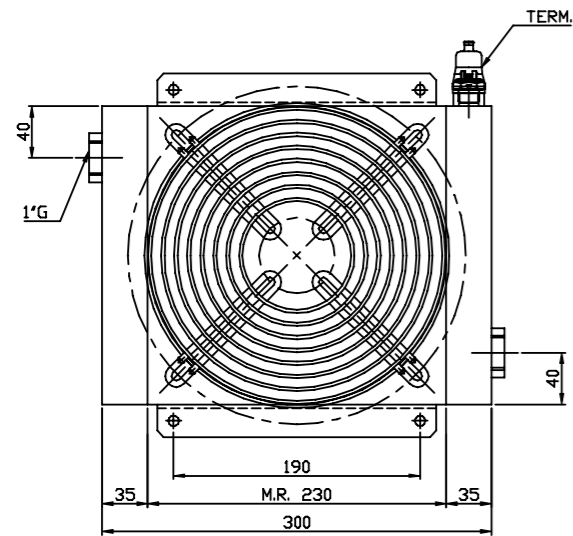

Vac

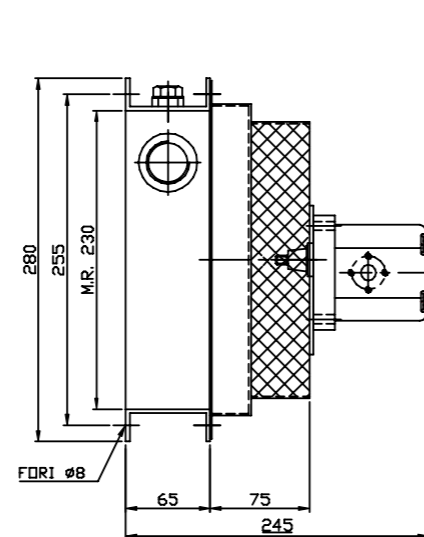
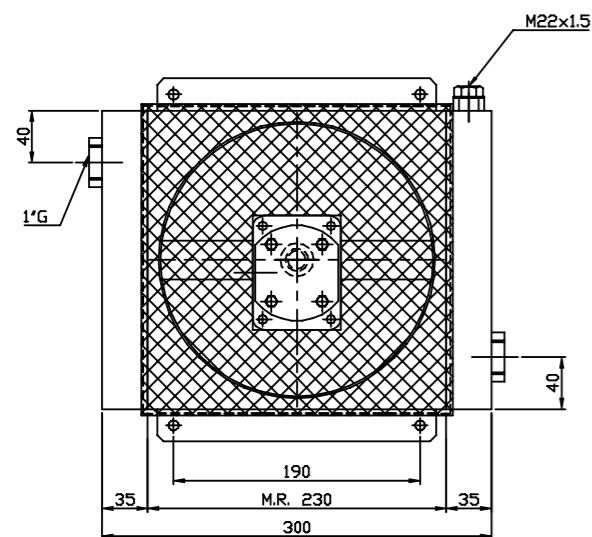

GR1

**DATI TECNICI - TECHNICAL DATA**

TENSIONE VOLTAGE	ASSORBIMENTO CURRENT	PORTATA ARIA AIR FLOW	PROTEZIONE PROTECTION	Ø
V	A	m <sup>3</sup> /h	IP	mm
12	7,7	1010	68	225
24	4,3	1070	68	225
230 Hz 50/60	0,30 / 0,34	890 / 990	44	200
230/400 Hz 50/60	0,17 / 0,13	890 / 990	44	200
Predisposizione GR1 - Prepared for GR1				190

**DIAGRAMMA DI RENDIMENTO - PERFORMANCE DIAGRAM**

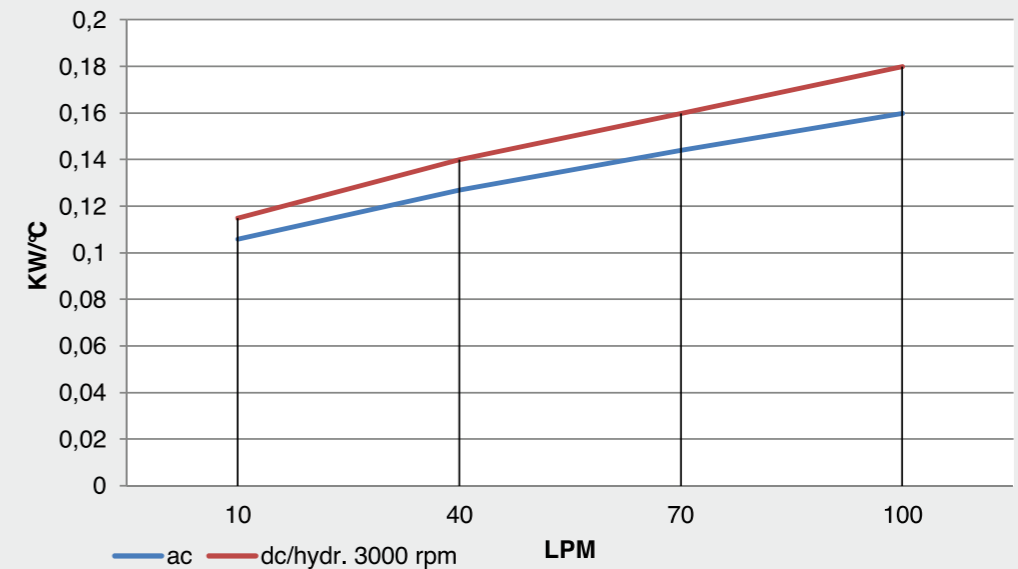

**DIAGRAMMA PERDITE DI CARICO - PRESSURE DROP DIAGRAM**

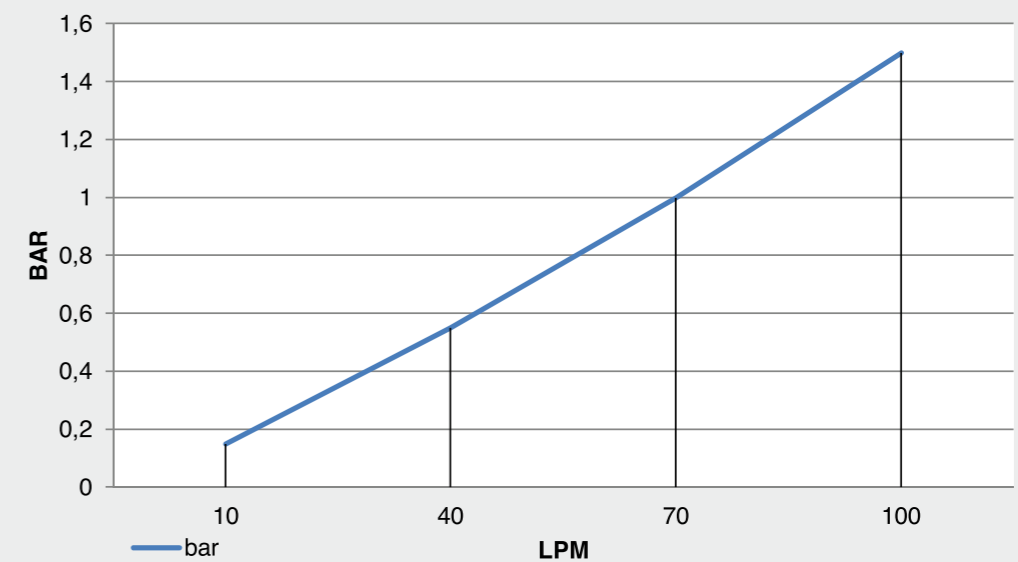

Portata olio - Oil flow: 20-100 lt/1'

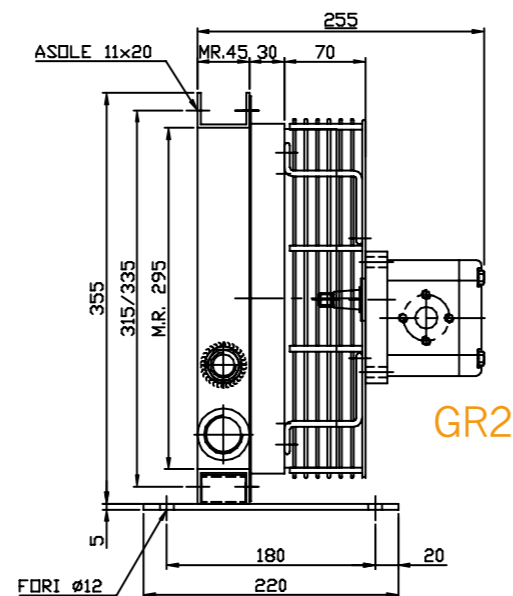
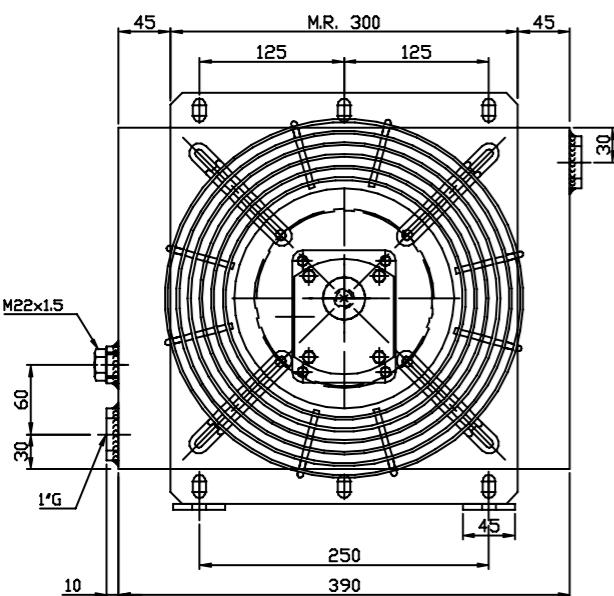
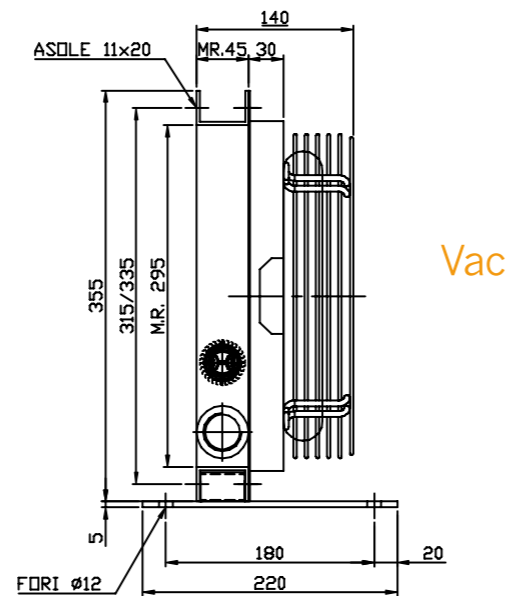
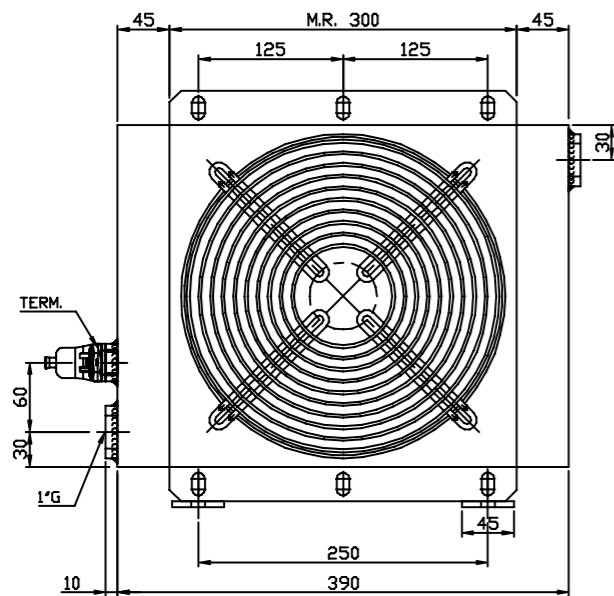
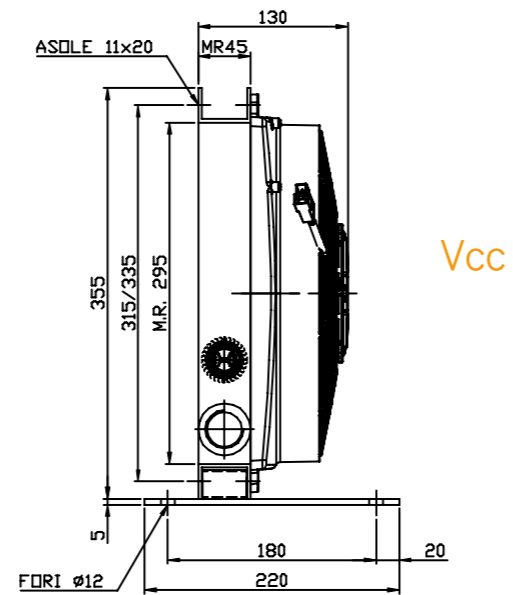
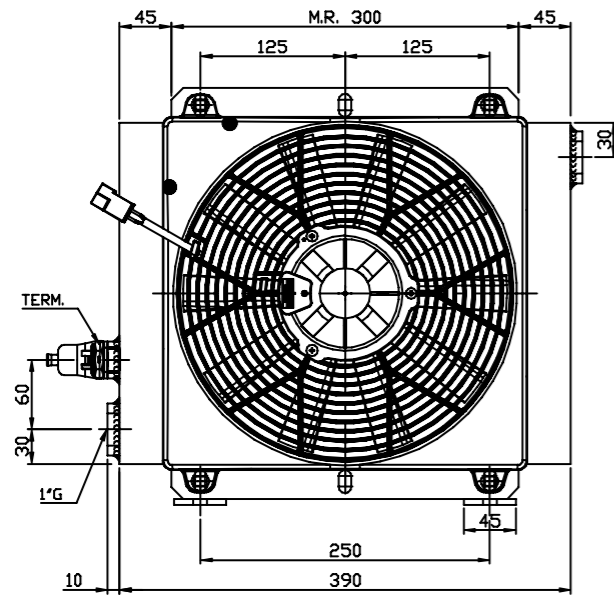

**DATI TECNICI - TECHNICAL DATA**

TENSIONE VOLTAGE	ASSORBIMENTO CURRENT	PORTATA ARIA AIR FLOW	PROTEZIONE PROTECTION	Ø
V	A	m <sup>3</sup> /h	IP	mm
12	7,8	1290	68	280
24	3,9	1270	68	280
230 Hz 50/60	0,51/ 0,66	1820 / 1970	44	250
230/400 Hz 50/60	0,34-0,20 / 0,40-0,23	1830 / 1950	44	250
Predisposizione GR2 - Prepared for GR2			/	280

**DIAGRAMMA DI RENDIMENTO - PERFORMANCE DIAGRAM**

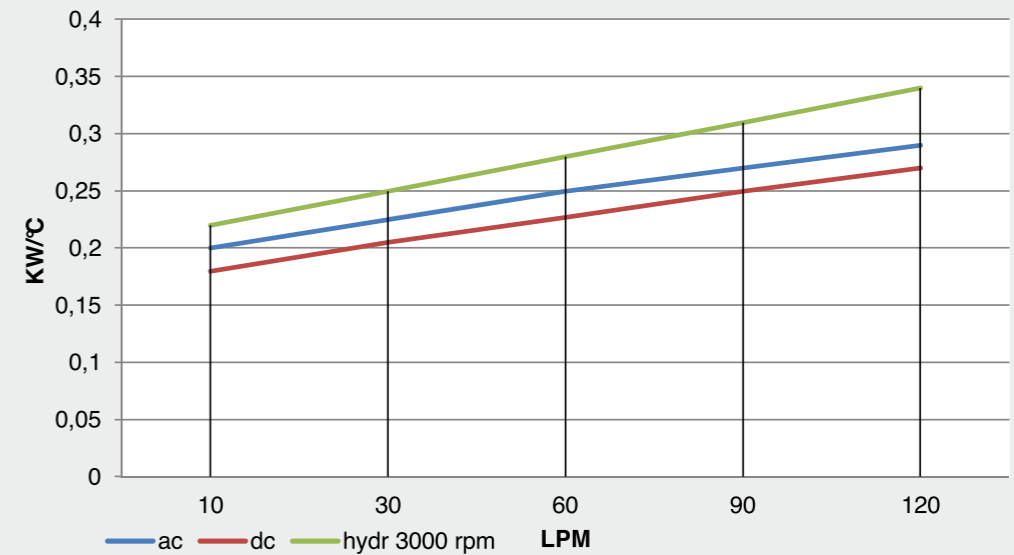

**DIAGRAMMA PERDITE DI CARICO - PRESSURE DROP DIAGRAM**

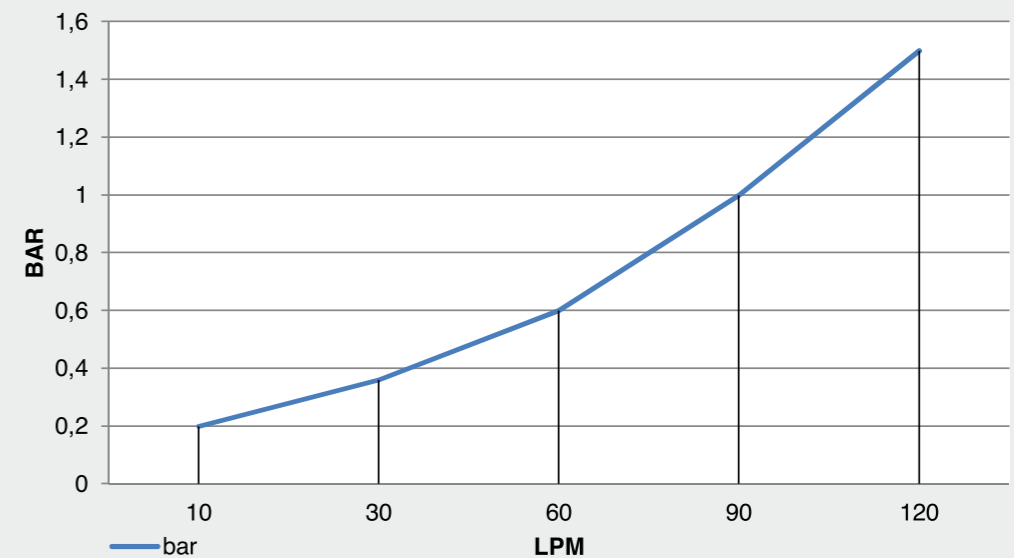

Portata olio - Oil flow: 10-120 lt/1'



Predisposizione per by-pass interno - Prepared for internal by-pass

Predisposizione per by-pass interno - Prepared for internal by-pass

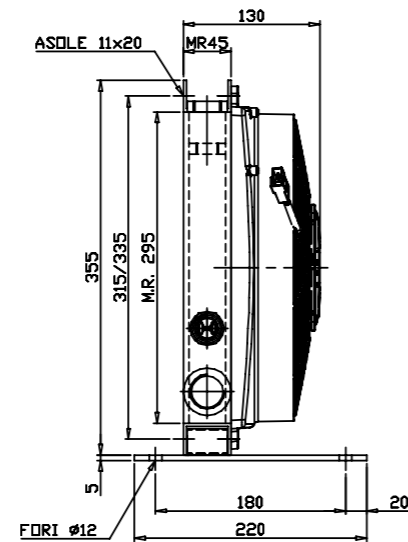
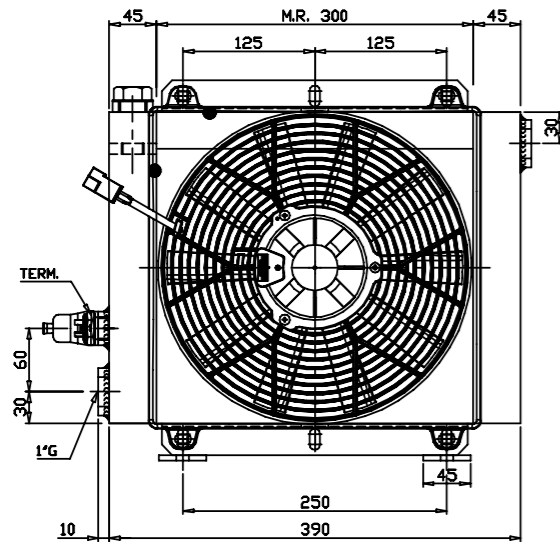

Vcc

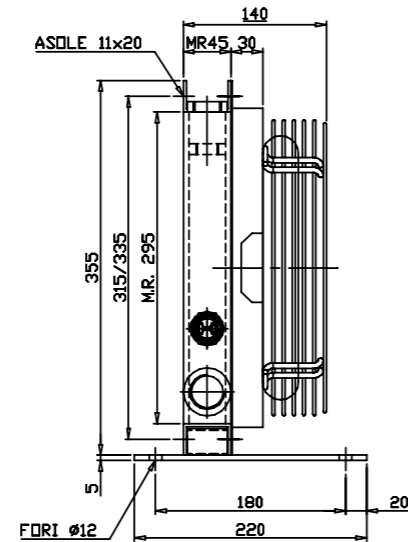
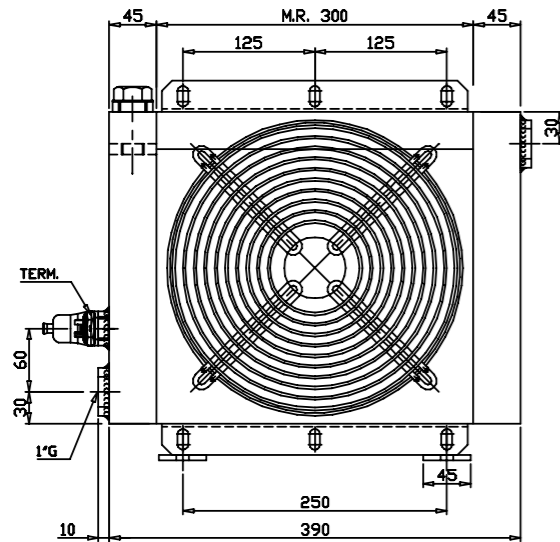

Vac

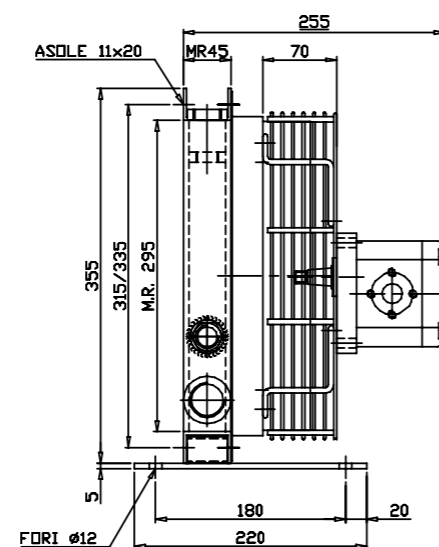
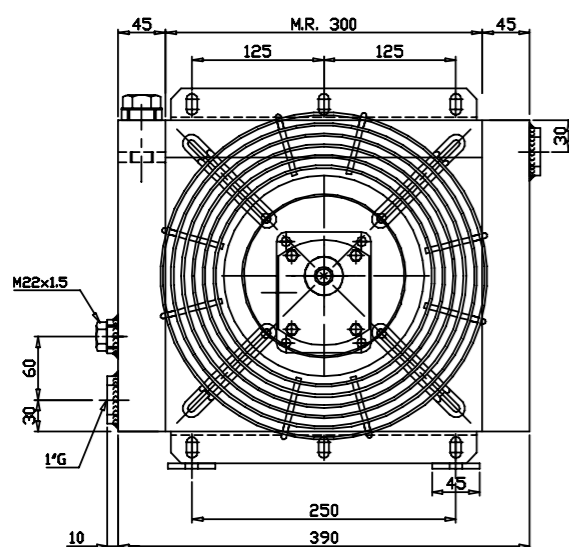

GR2

**DATI TECNICI - TECHNICAL DATA**

TENSIONE VOLTAGE	ASSORBIMENTO CURRENT	PORTATA ARIA AIR FLOW	PROTEZIONE PROTECTION	Ø
V	A	m <sup>3</sup> /h	IP	mm
12	7,8	1290	68	280
24	3,9	1270	68	280
230 Hz 50/60	0,51/ 0,66	1820 / 1970	44	250
230/400 Hz 50/60	0,34-0,20 / 0,40-0,23	1830 / 1950	44	250
Predisposizione GR2 - Prepared for GR2				280

**DIAGRAMMA DI RENDIMENTO - PERFORMANCE DIAGRAM**

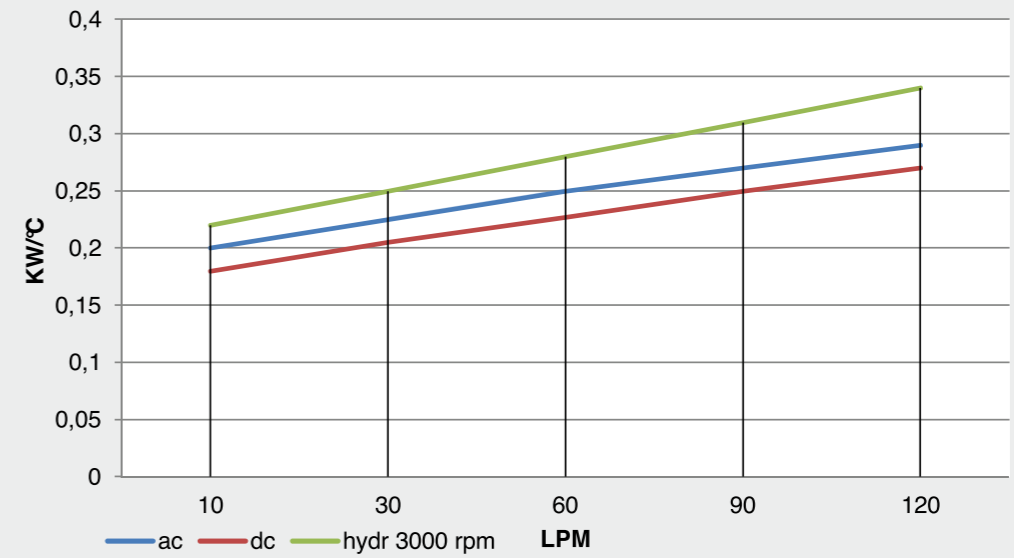

**DIAGRAMMA PERDITE DI CARICO - PRESSURE DROP DIAGRAM**

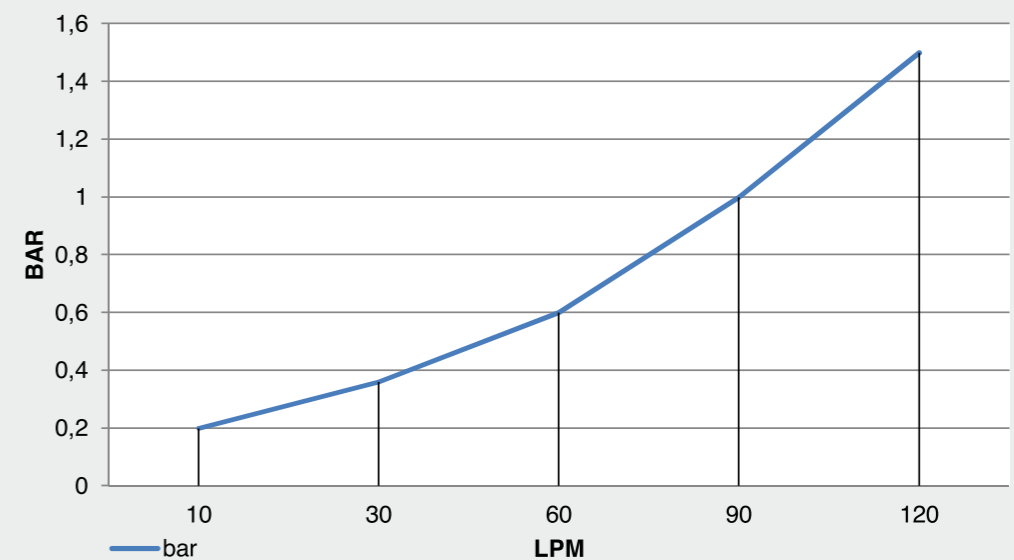

Portata olio - Oil flow: 10-120 lt/1'

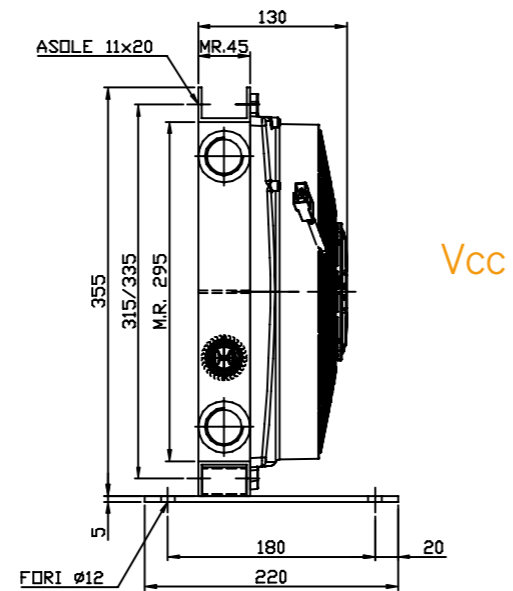
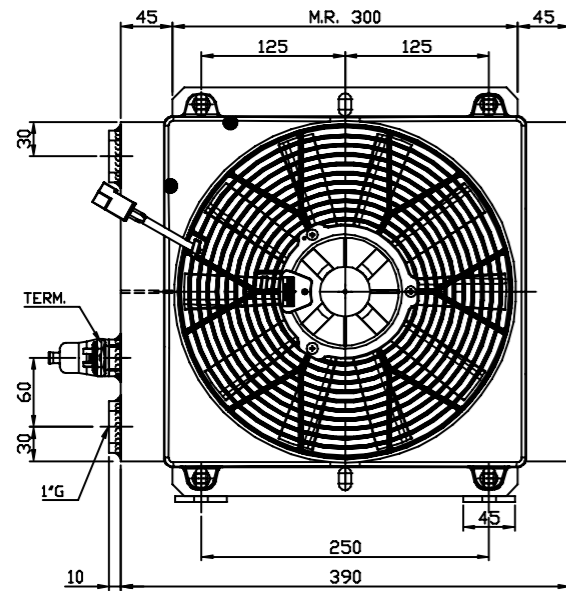

Vcc

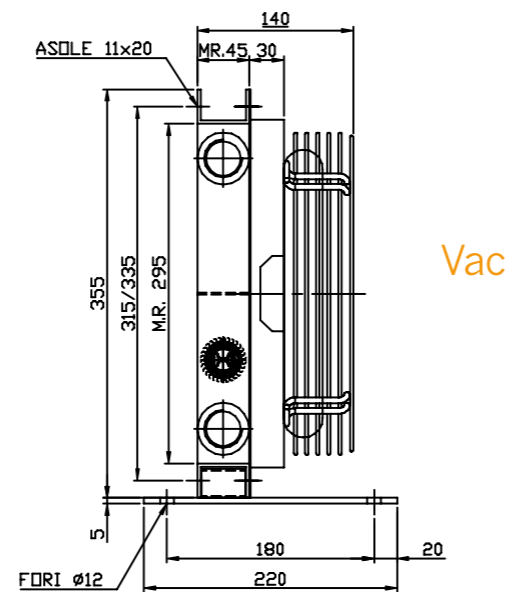
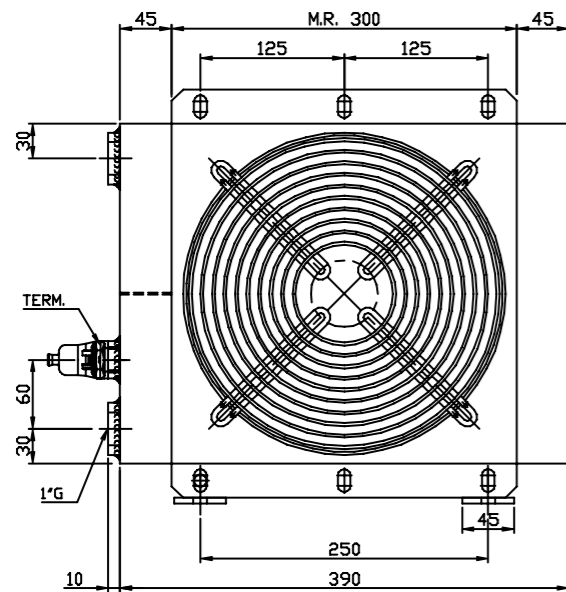

Vac

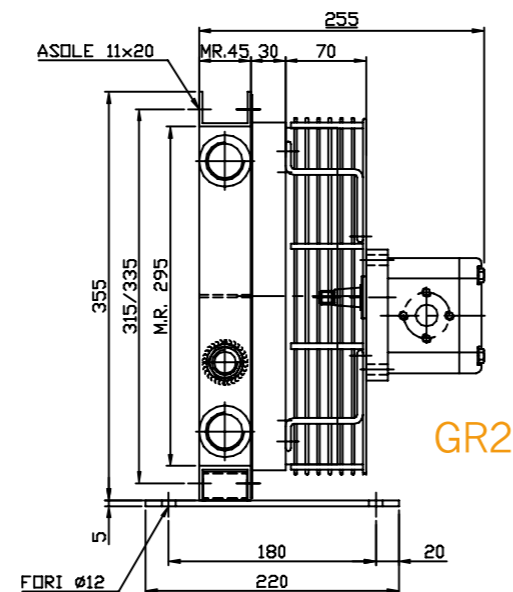
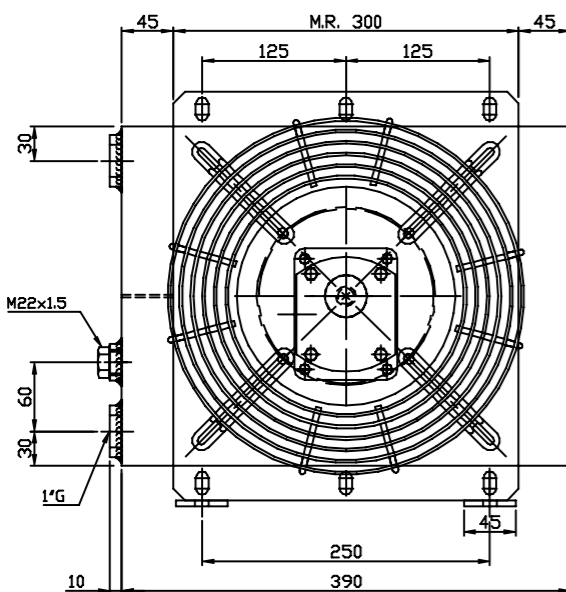

GR2

**DATI TECNICI - TECHNICAL DATA**

TENSIONE VOLTAGE	ASSORBIMENTO CURRENT	PORTATA ARIA AIR FLOW	PROTEZIONE PROTECTION	Ø
V	A	m <sup>3</sup> /h	IP	mm
12	7,8	1290	68	280
24	3,9	1270	68	280
230 Hz 50/60	0,51/ 0,66	1820 / 1970	44	250
230/400 Hz 50/60	0,34-0,20 / 0,40-0,23	1830 / 1950	44	250
Predisposizione GR2 - Prepared for GR2				280

**DIAGRAMMA DI RENDIMENTO - PERFORMANCE DIAGRAM**

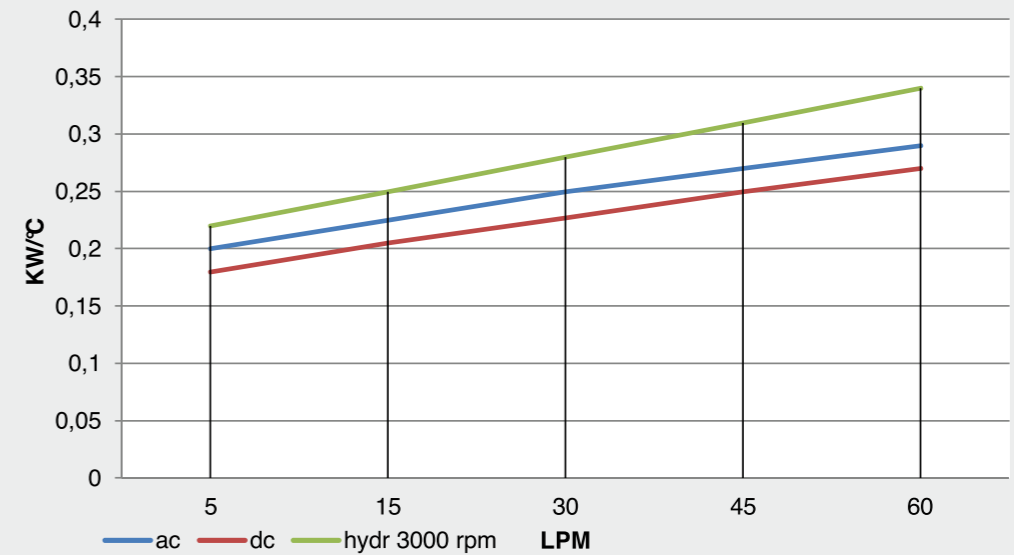

**DIAGRAMMA PERDITE DI CARICO - PRESSURE DROP DIAGRAM**

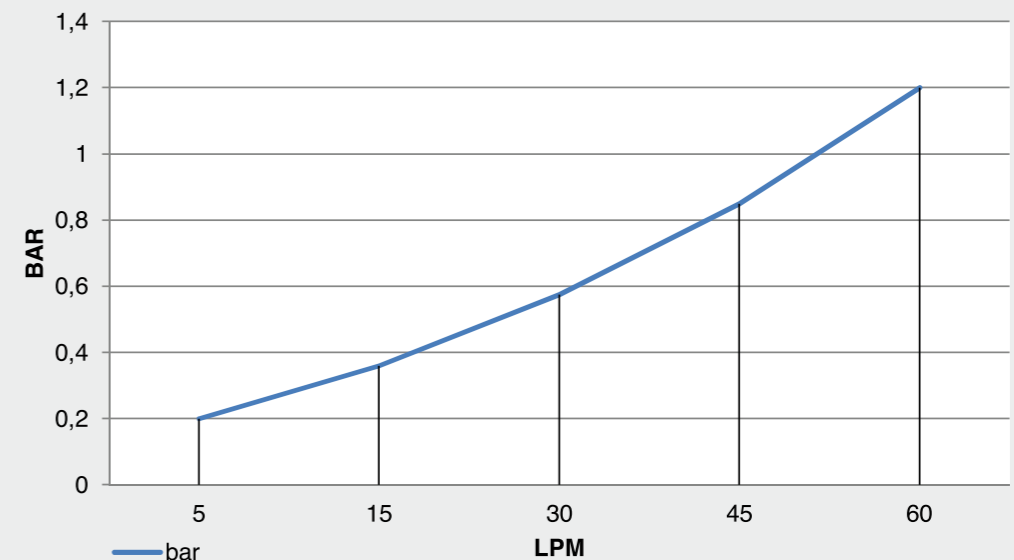

Portata olio - Oil flow: 5-60 lt/1'

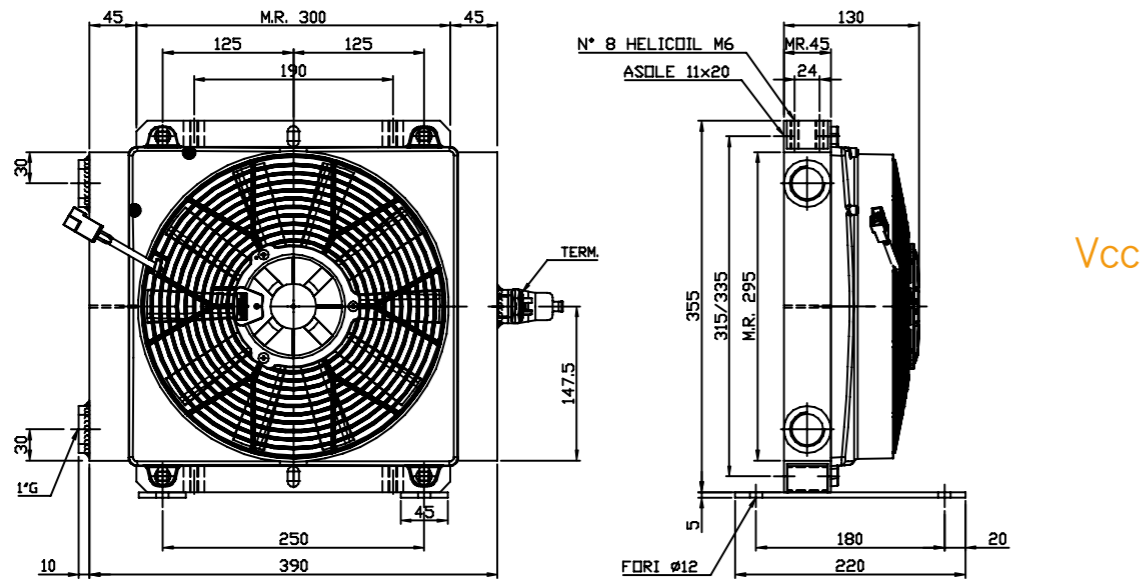

Vcc

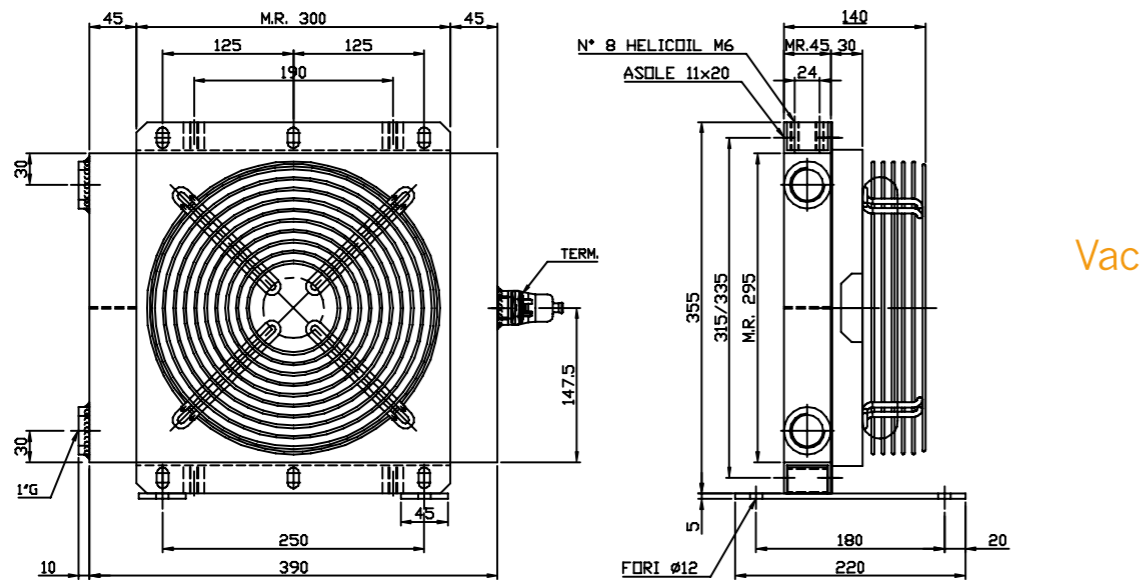

Vac

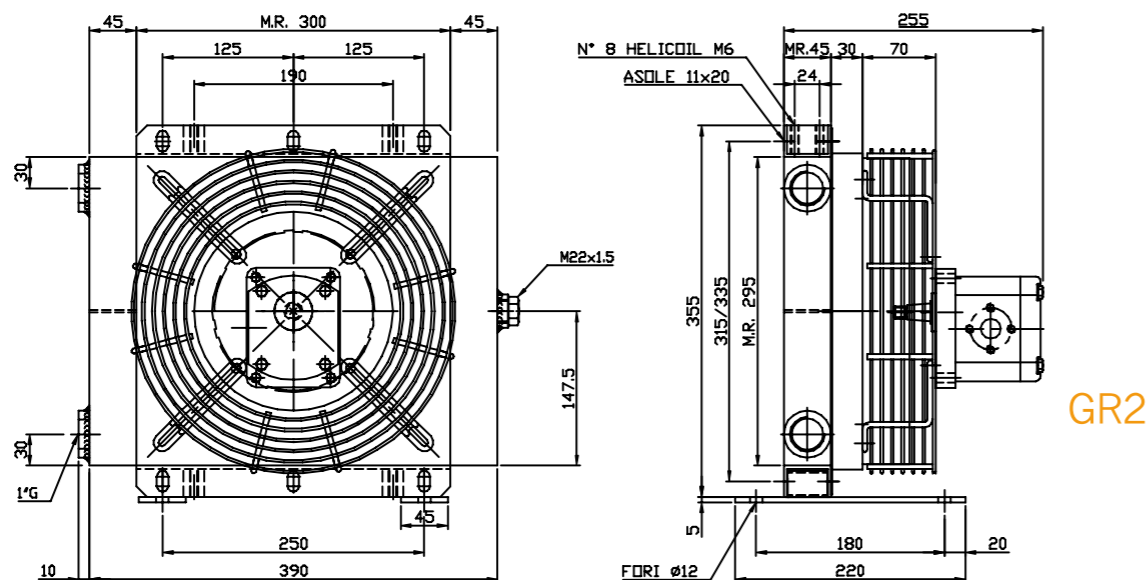

GR2

**DATI TECNICI - TECHNICAL DATA**

TENSIONE VOLTAGE	ASSORBIMENTO CURRENT	PORTATA ARIA AIR FLOW	PROTEZIONE PROTECTION	Ø
V	A	m <sup>3</sup> /h	IP	mm
12	7,8	1290	68	280
24	3,9	1270	68	280
230 Hz 50/60	0,51/ 0,66	1820 / 1970	44	250
230/400 Hz 50/60	0,34-0,20 / 0,40-0,23	1830 / 1950	44	250
Predisposizione GR2 - Prepared for GR2				280

**DIAGRAMMA DI RENDIMENTO - PERFORMANCE DIAGRAM**

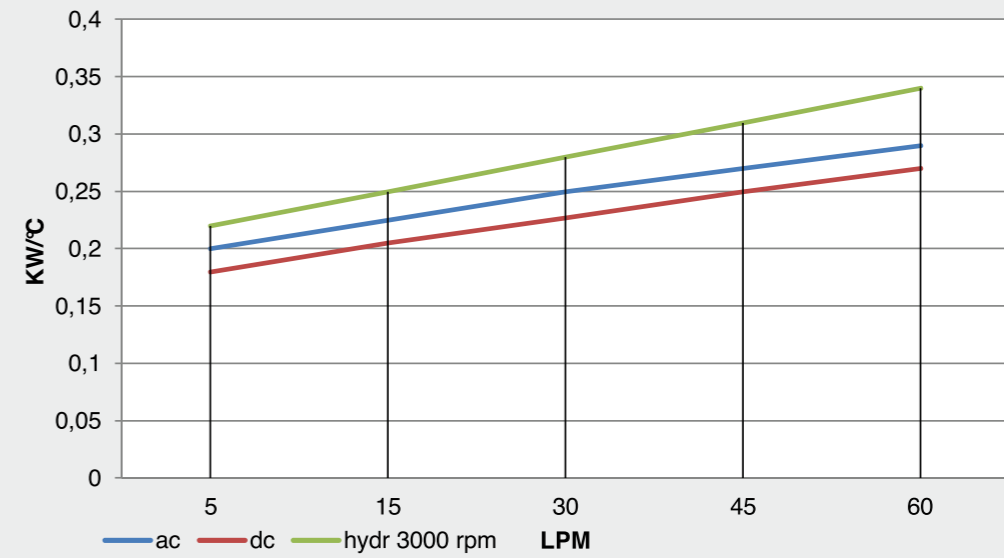

**DIAGRAMMA PERDITE DI CARICO - PRESSURE DROP DIAGRAM**

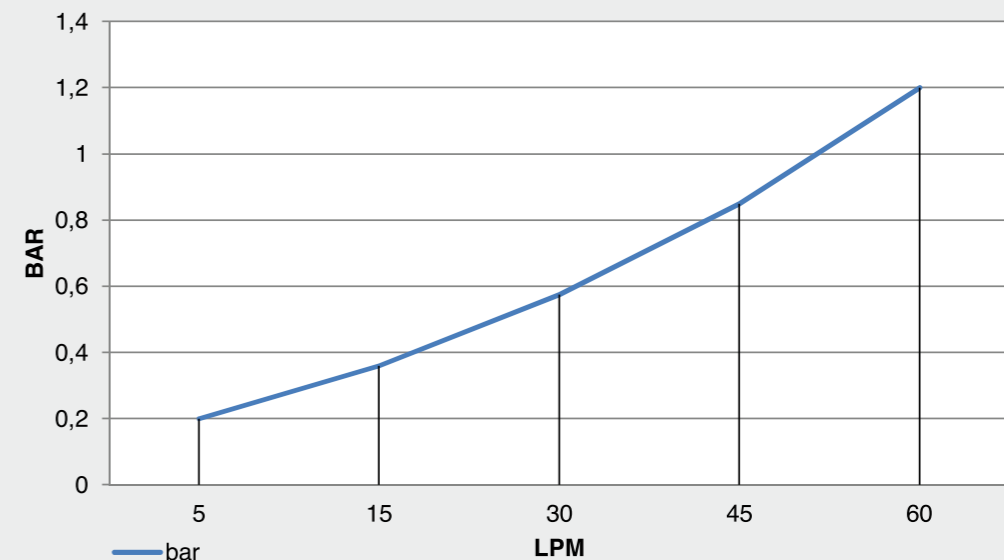

Portata olio - Oil flow: 5-60 lt/1'

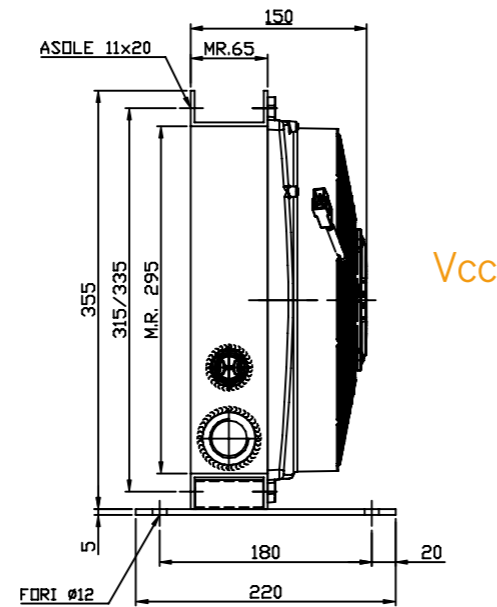
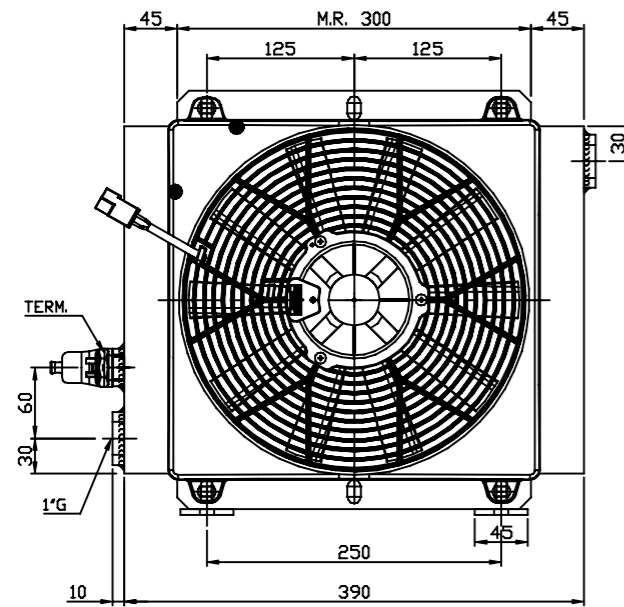

Vcc

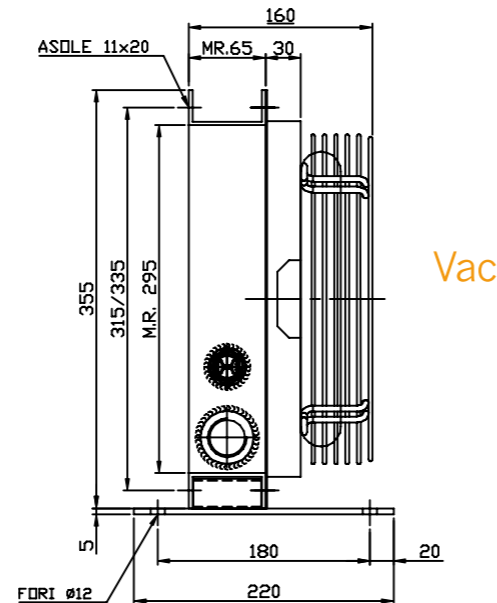
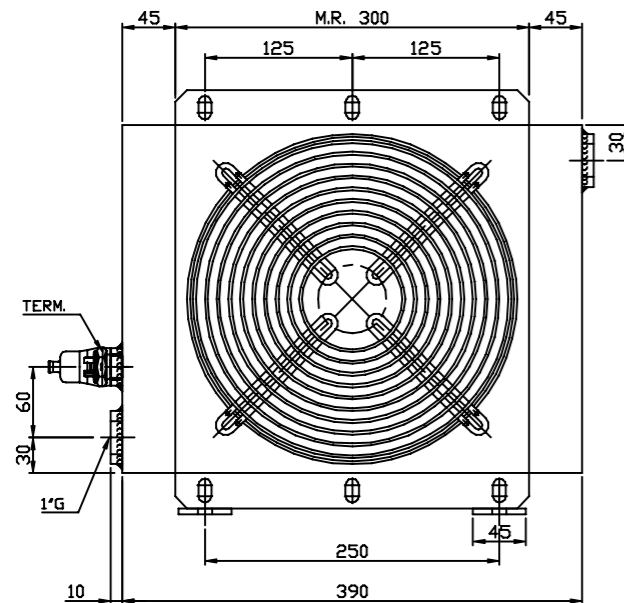

Vac

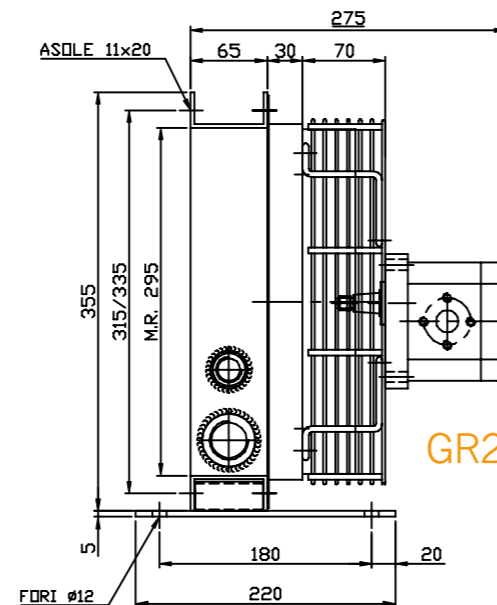
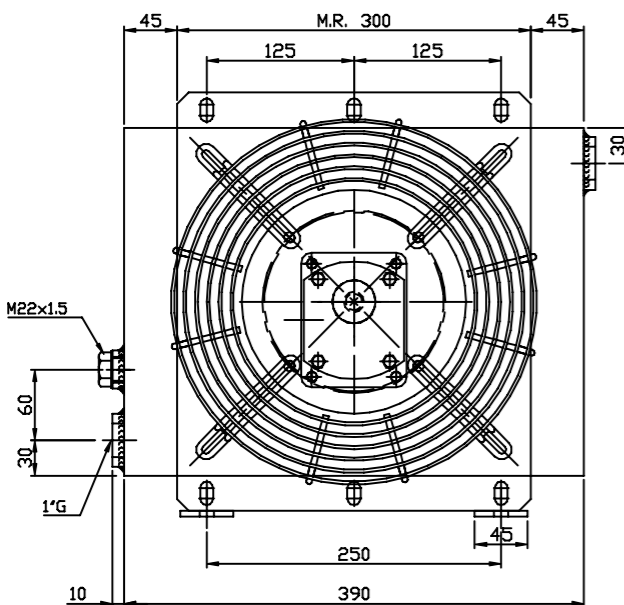

GR2

**DATI TECNICI - TECHNICAL DATA**

TENSIONE VOLTAGE	ASSORBIMENTO CURRENT	PORTATA ARIA AIR FLOW	PROTEZIONE PROTECTION	Ø
V	A	m <sup>3</sup> /h	IP	mm
12	7,8	1290	68	280
24	3,9	1270	68	280
230 Hz 50/60	0,51/ 0,66	1820 / 1970	44	250
230/400 Hz 50/60	0,34-0,20 / 0,40-0,23	1830 / 1950	44	250
Predisposizione GR2 - Prepared for GR2				280

**DIAGRAMMA DI RENDIMENTO - PERFORMANCE DIAGRAM**

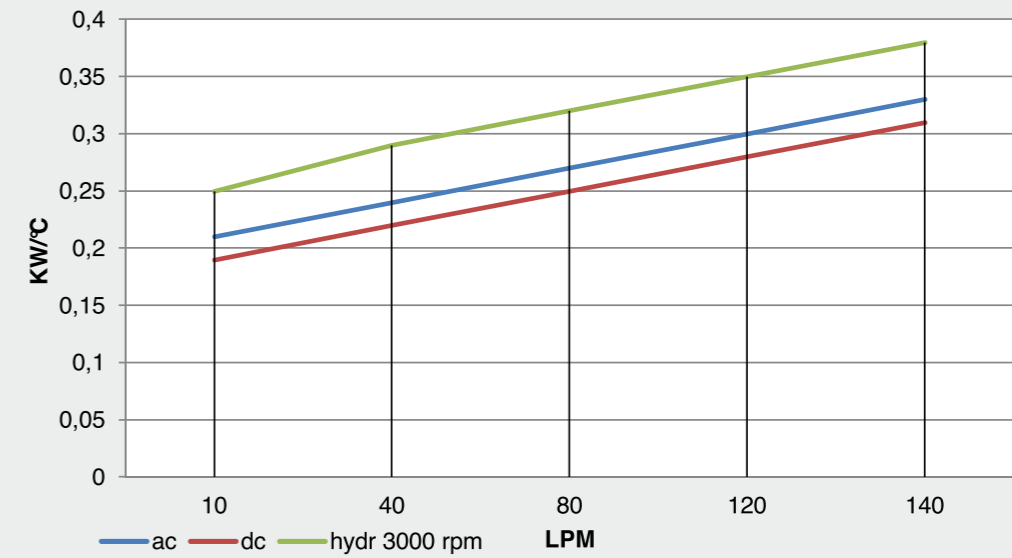

**DIAGRAMMA PERDITE DI CARICO - PRESSURE DROP DIAGRAM**

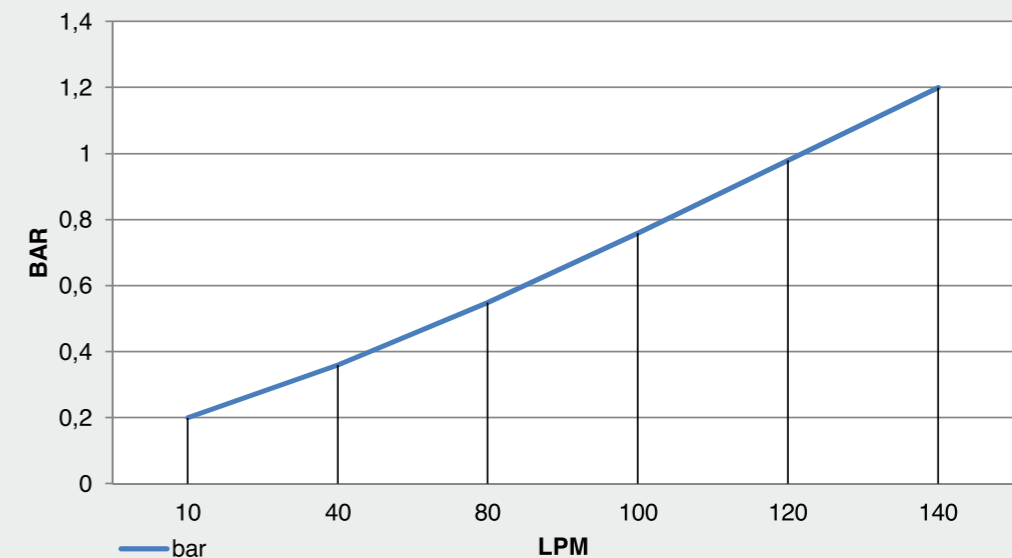

Portata olio - Oil flow: 10-140 lt/1'

Predisposizione per by-pass interno - Prepared for internal by-pass

Predisposizione per by-pass interno - Prepared for internal by-pass

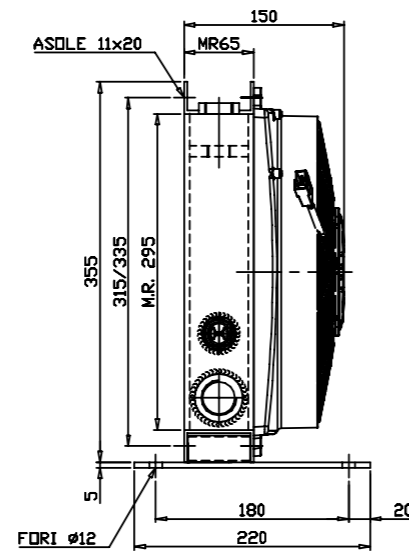
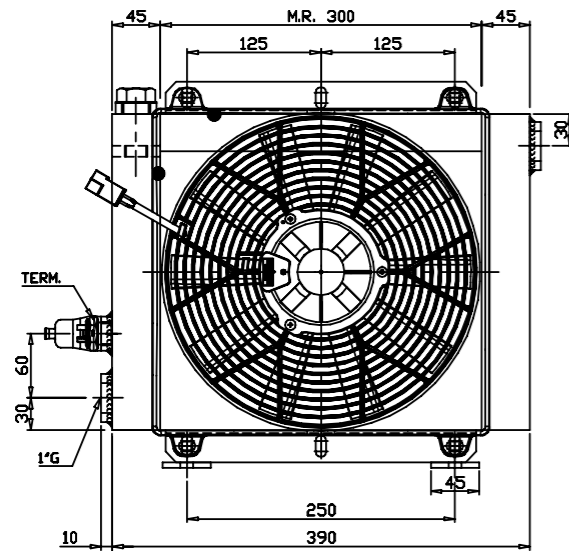

Vcc

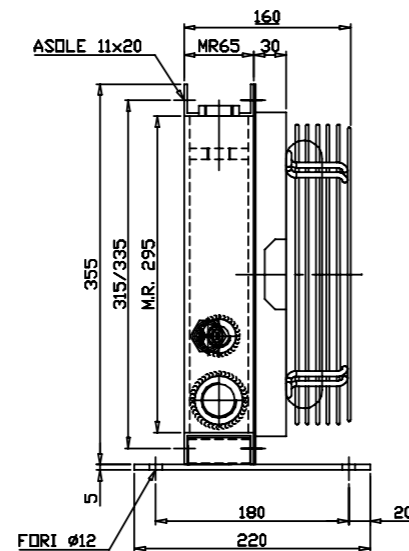
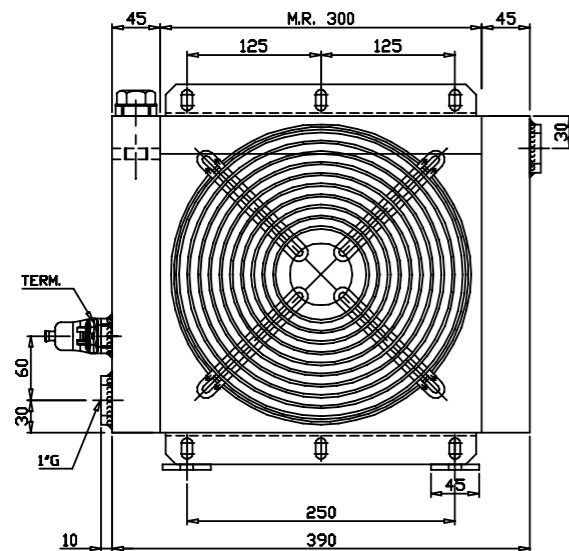

Vac

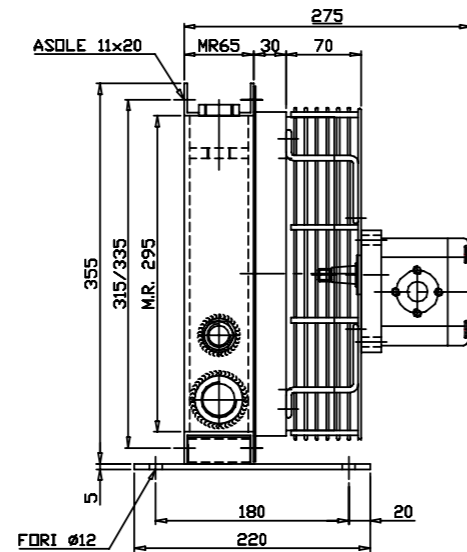
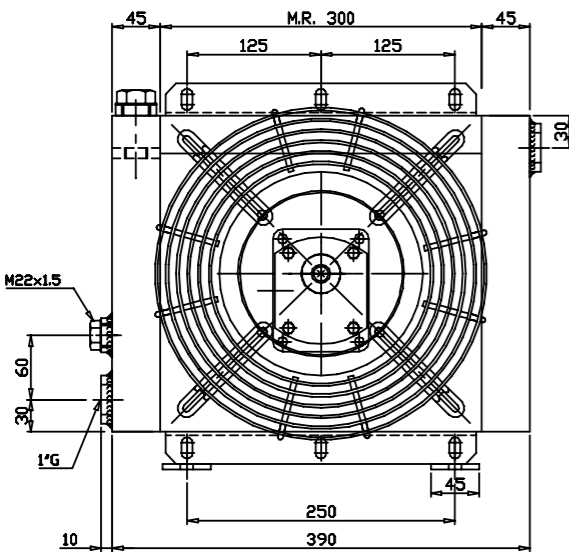

GR2

**DATI TECNICI - TECHNICAL DATA**

TENSIONE VOLTAGE	ASSORBIMENTO CURRENT	PORTATA ARIA AIR FLOW	PROTEZIONE PROTECTION	Ø
V	A	m <sup>3</sup> /h	IP	mm
12	7,8	1290	68	280
24	3,9	1270	68	280
230 Hz 50/60	0,51/ 0,66	1820 / 1970	44	250
230/400 Hz 50/60	0,34-0,20 / 0,40-0,23	1830 / 1950	44	250
Predisposizione GR2 - Prepared for GR2				280

**DIAGRAMMA DI RENDIMENTO - PERFORMANCE DIAGRAM**

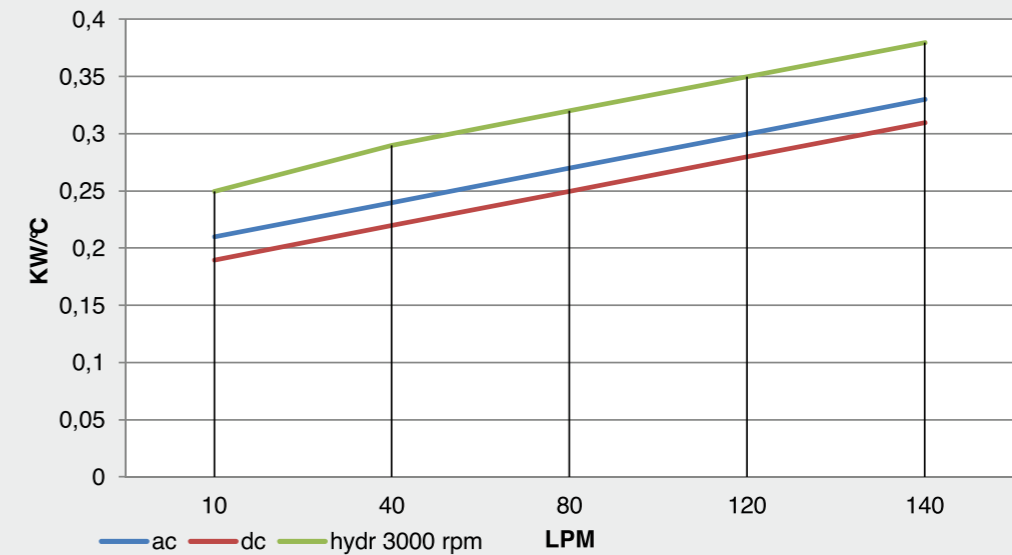

**DIAGRAMMA PERDITE DI CARICO - PRESSURE DROP DIAGRAM**

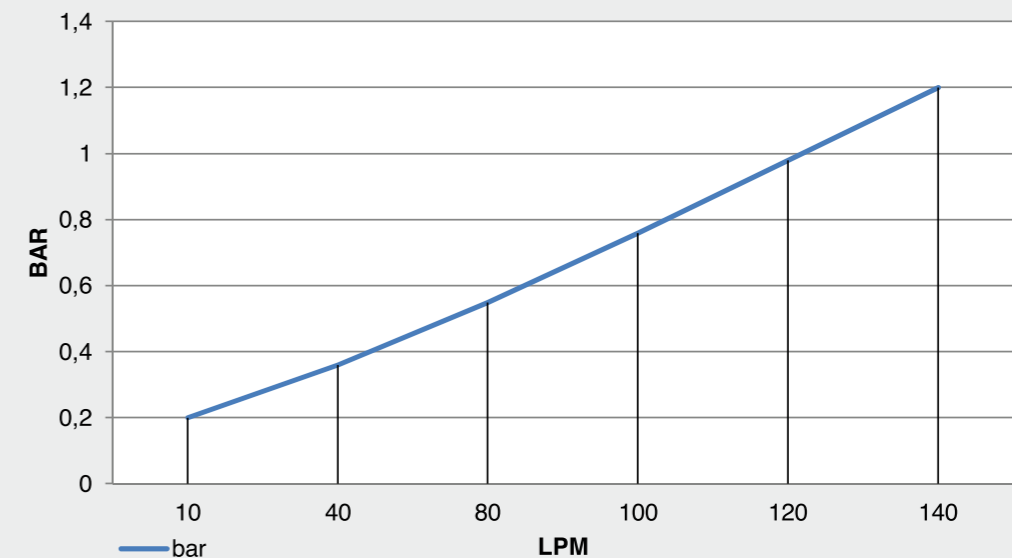

Portata olio - Oil flow: 10-140 lt/1'

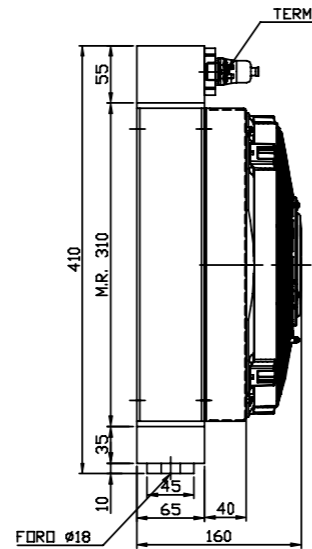
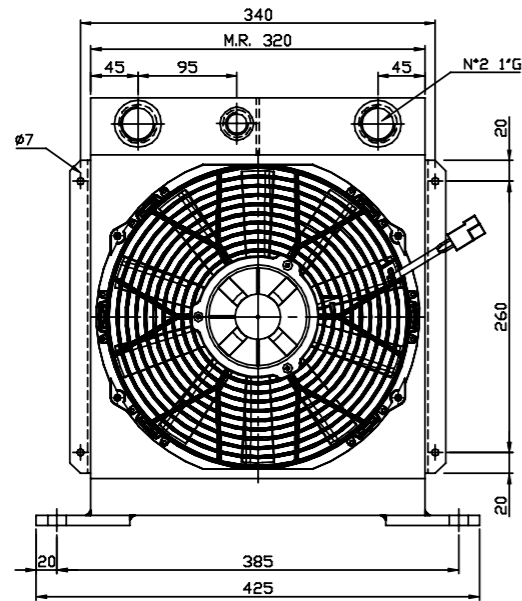

Vcc

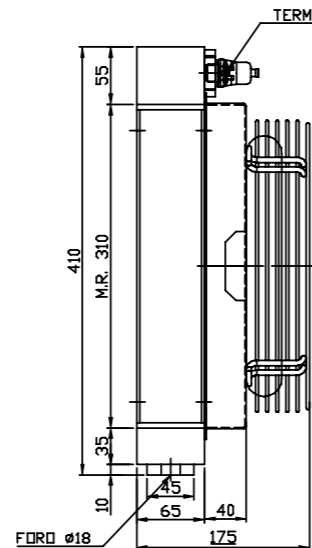
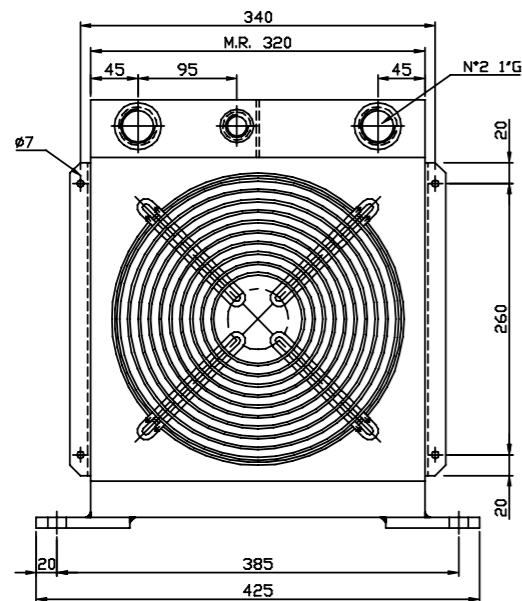

Vac

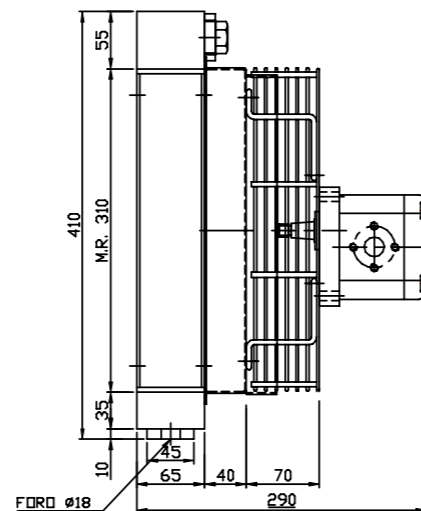
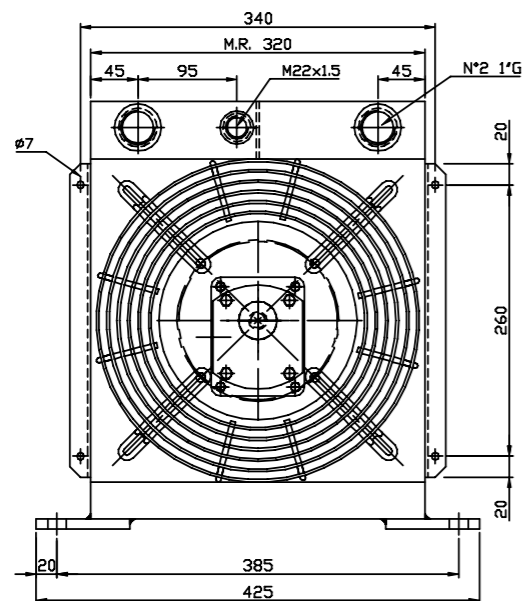

GR2

**DATI TECNICI - TECHNICAL DATA**

TENSIONE VOLTAGE	ASSORBIMENTO CURRENT	PORTATA ARIA AIR FLOW	PROTEZIONE PROTECTION	Ø
V	A	m <sup>3</sup> /h	IP	mm
12	7,8	1290	68	280
24	3,9	1270	68	280
230 Hz 50/60	0,51/ 0,66	1820 / 1970	44	250
230/400 Hz 50/60	0,34-0,20 / 0,40-0,23	1830 / 1950	44	250
Predisposizione GR2 - Prepared for GR2			/	280

**DIAGRAMMA DI RENDIMENTO - PERFORMANCE DIAGRAM**

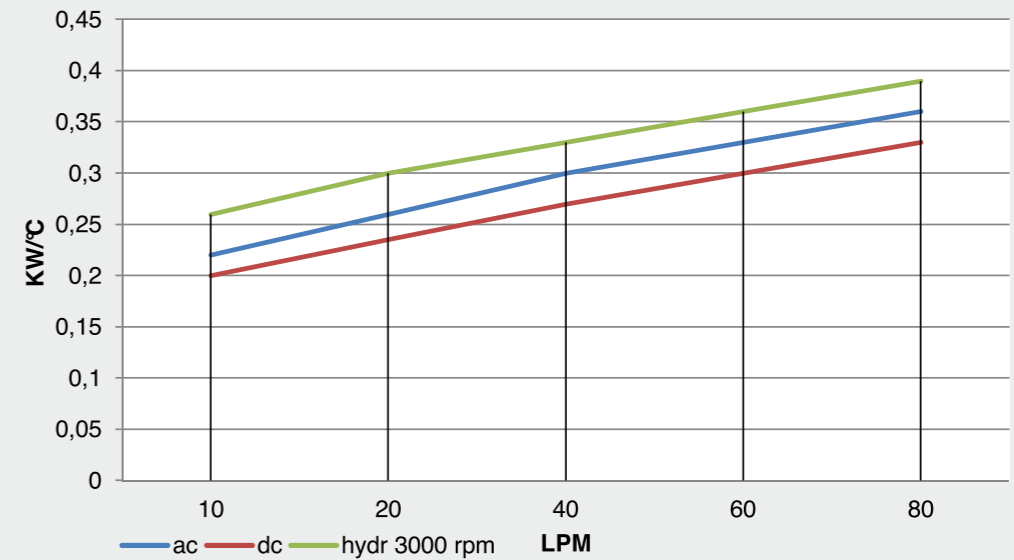

**DIAGRAMMA PERDITE DI CARICO - PRESSURE DROP DIAGRAM**

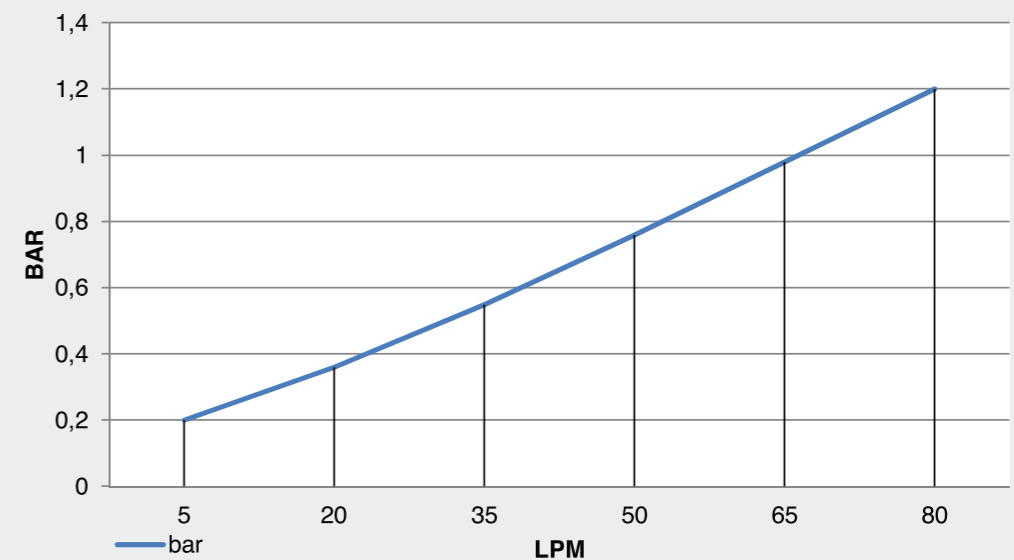

Portata olio - Oil flow: 5-80 lt/1'

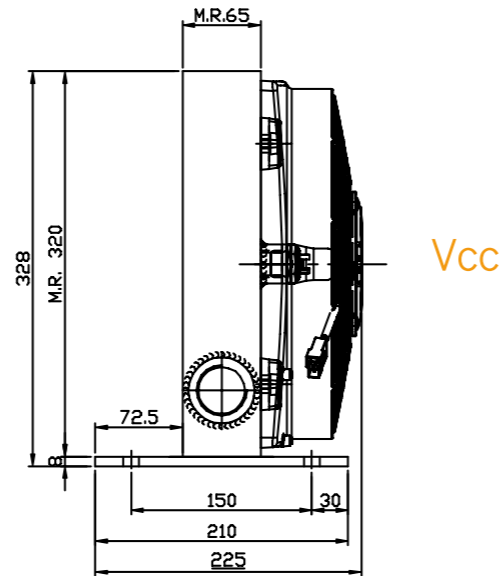
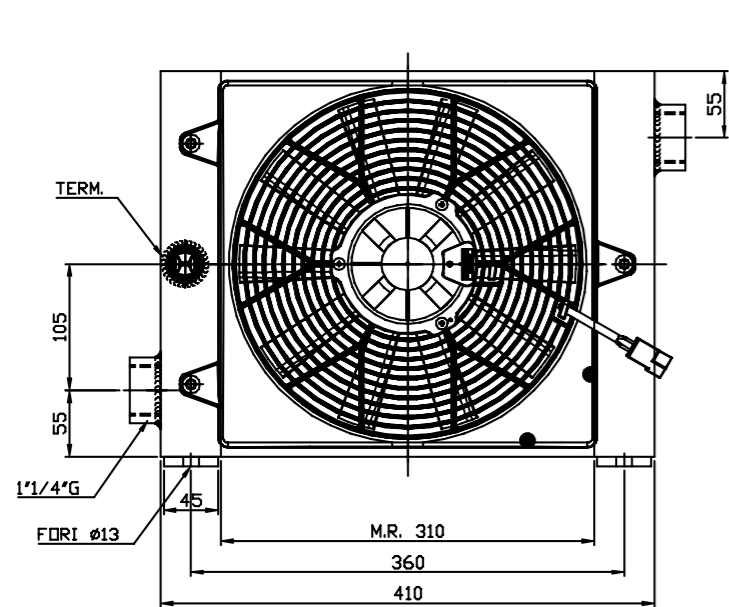

Vcc

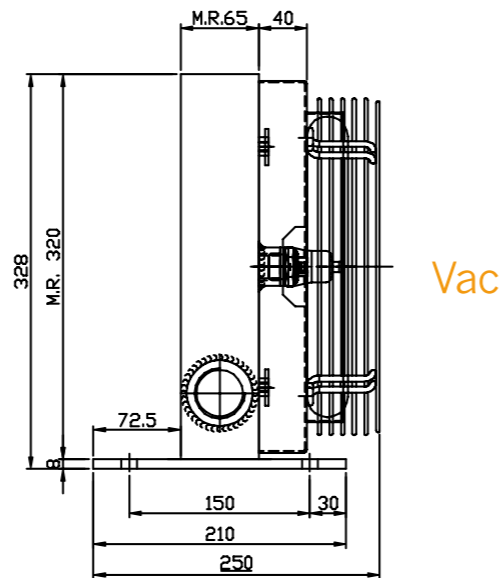
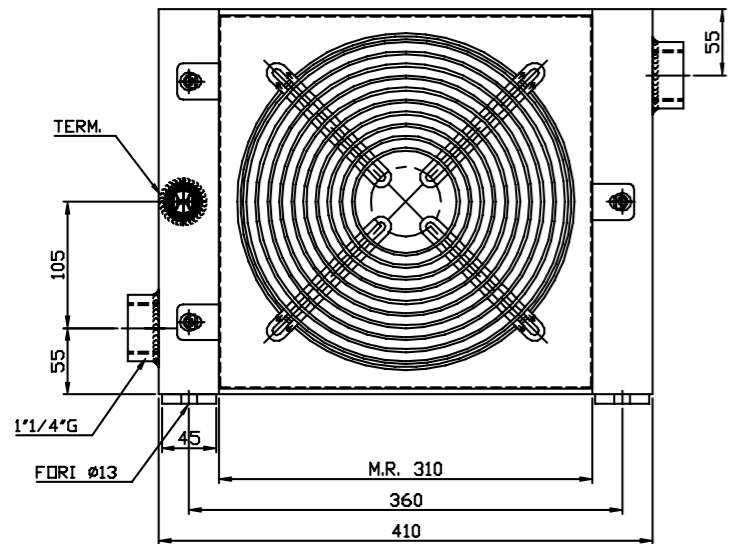

Vac

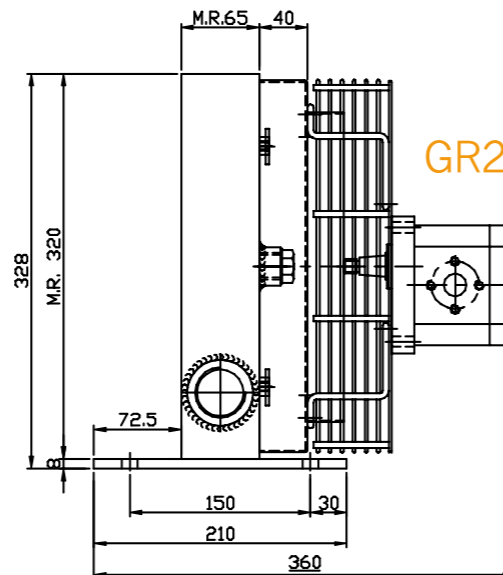
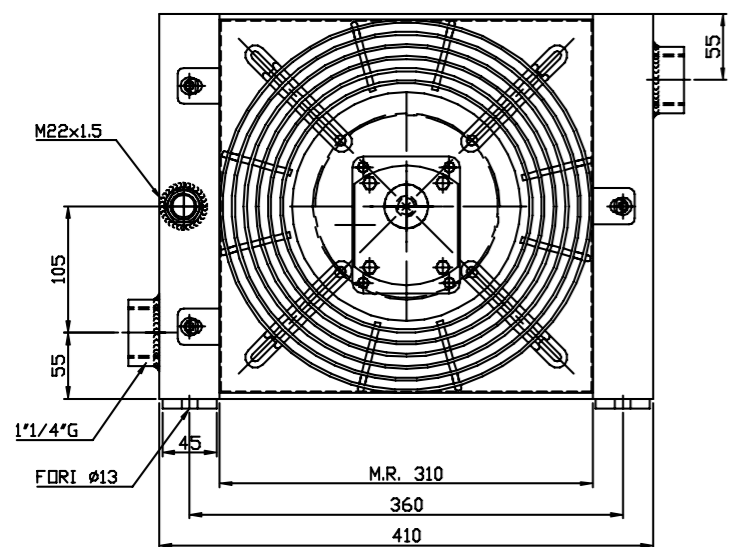

GR2

**DATI TECNICI - TECHNICAL DATA**

TENSIONE VOLTAGE	ASSORBIMENTO CURRENT	PORTATA ARIA AIR FLOW	PROTEZIONE PROTECTION	Ø
V	A	m <sup>3</sup> /h	IP	mm
12	7,3	1450	68	280
24	3,7	1470	68	280
230 Hz 50/60	0,51/ 0,66	1820 / 1970	44	250
230/400 Hz 50/60	0,34-0,20 / 0,40-0,23	1830 / 1950	44	250
Predisposizione GR2 - Prepared for GR2				280

**DIAGRAMMA DI RENDIMENTO - PERFORMANCE DIAGRAM**

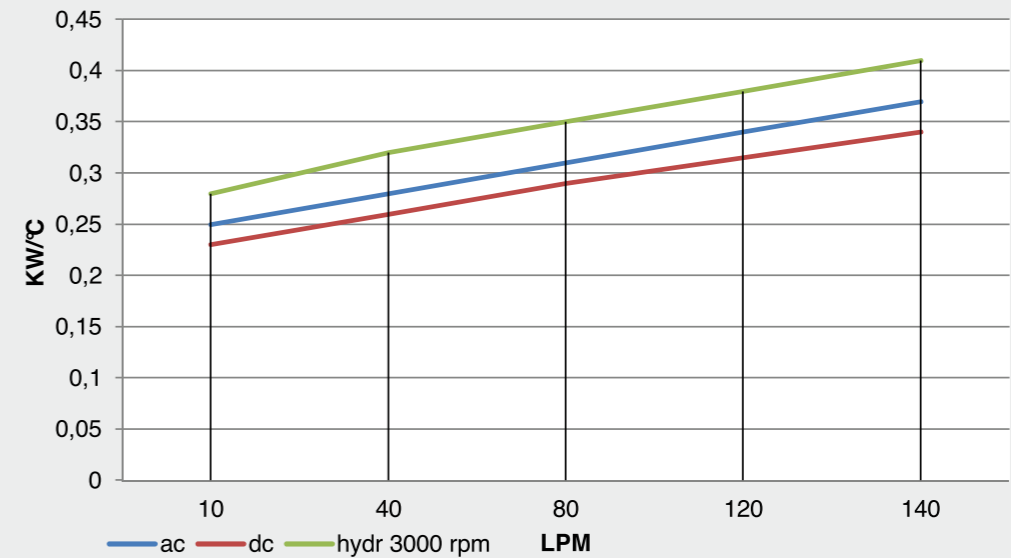

**DIAGRAMMA PERDITE DI CARICO - PRESSURE DROP DIAGRAM**

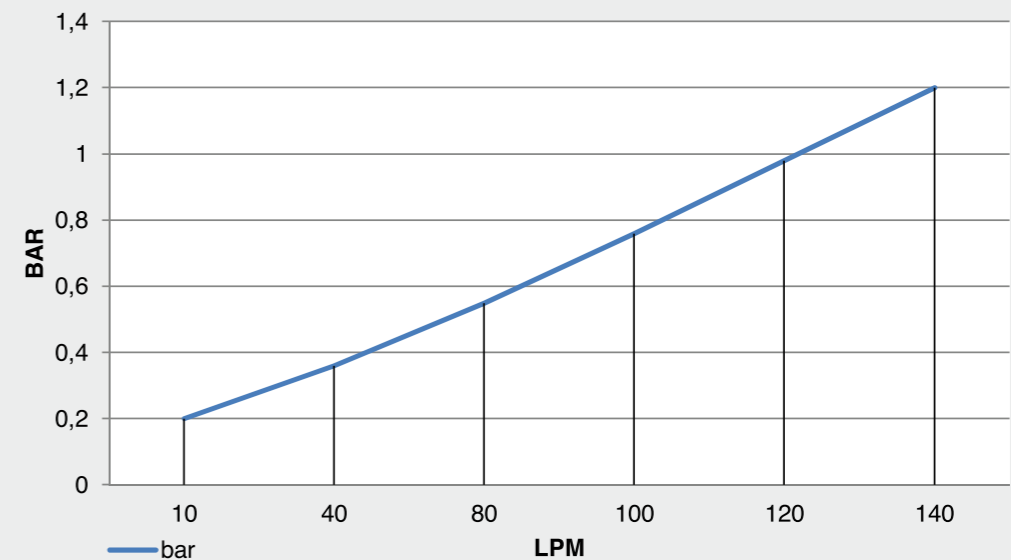

Portata olio - Oil flow: 10-140 lt/1'

**DATI TECNICI - TECHNICAL DATA**

TENSIONE VOLTAGE	ASSORBIMENTO CURRENT	PORTATA ARIA AIR FLOW	PROTEZIONE PROTECTION	Ø
V	A	m <sup>3</sup> /h	IP	mm
12	15,2	2060	68	280
24	7,1	2060	68	280
230 Hz 50/60	0,51/ 0,66	1820 / 1970	44	250
230/400 Hz 50/60	0,34-0,20 / 0,40-0,23	1830 / 1950	44	250
Predisposizione GR2 - Prepared for GR2			/	280

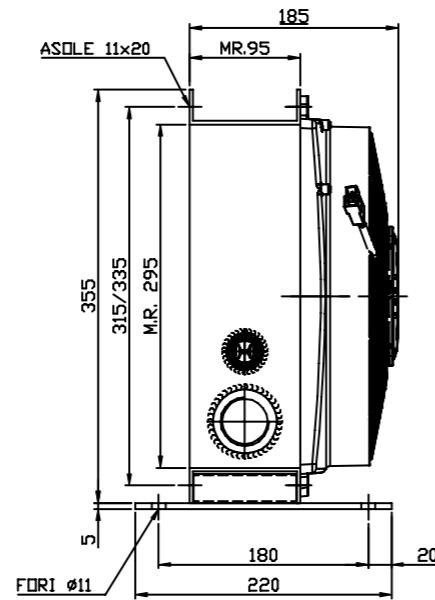
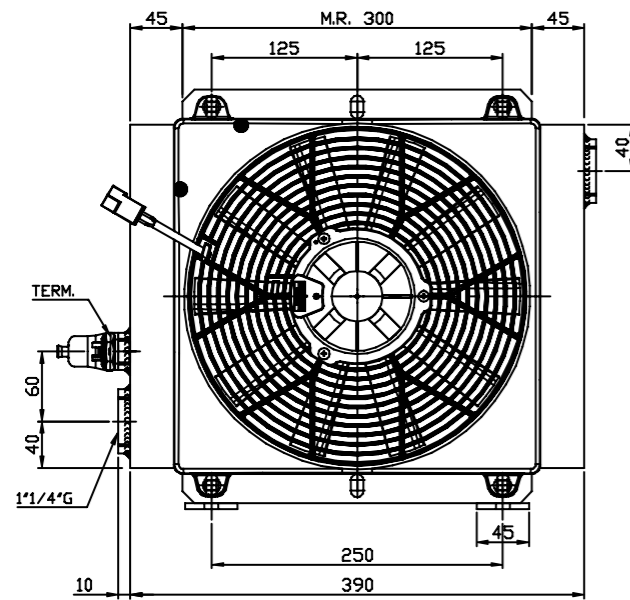

Vcc

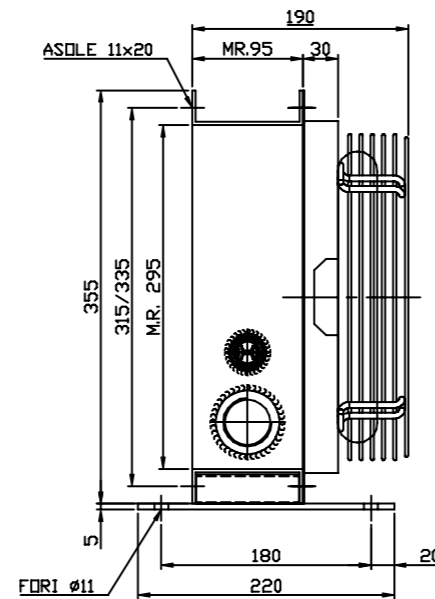
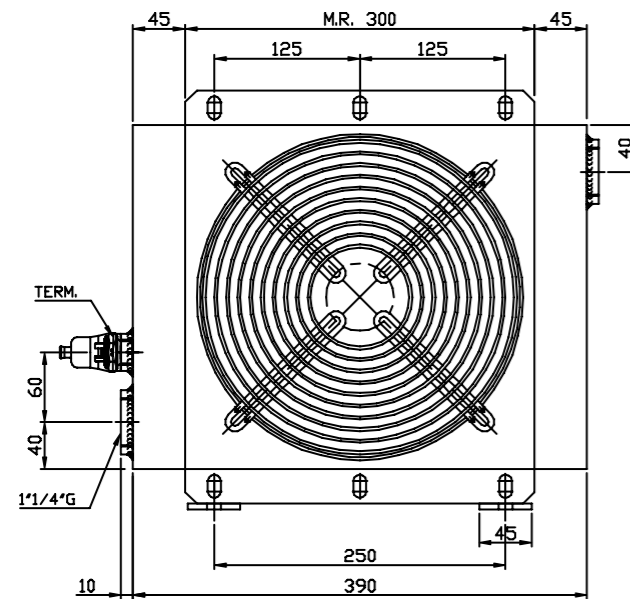

Vac

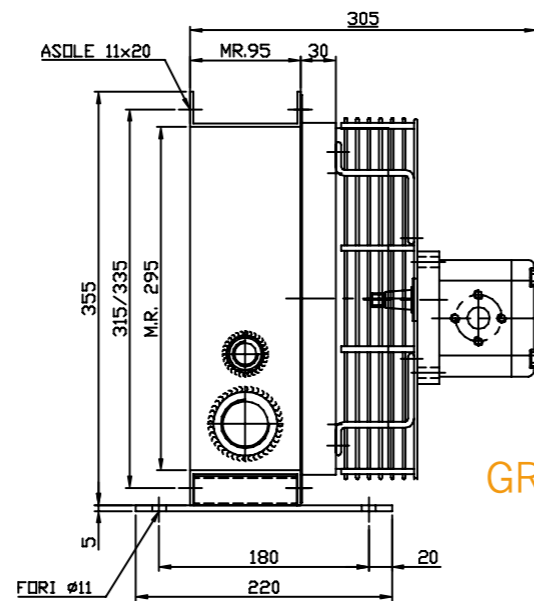
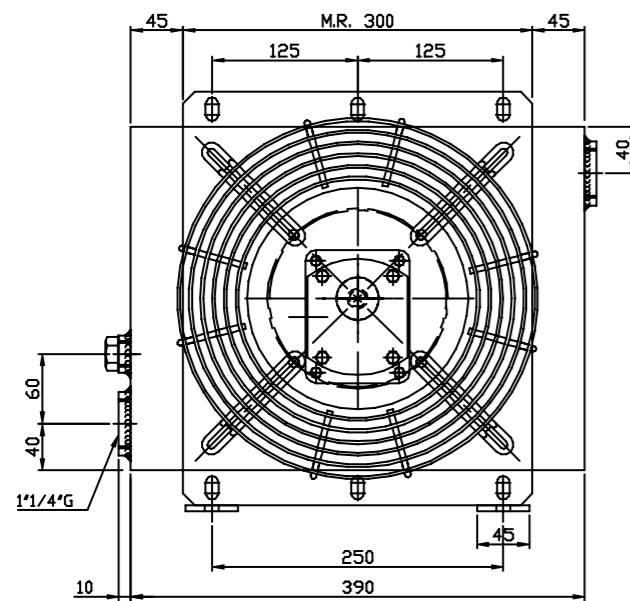

GR2

**DIAGRAMMA DI RENDIMENTO - PERFORMANCE DIAGRAM**

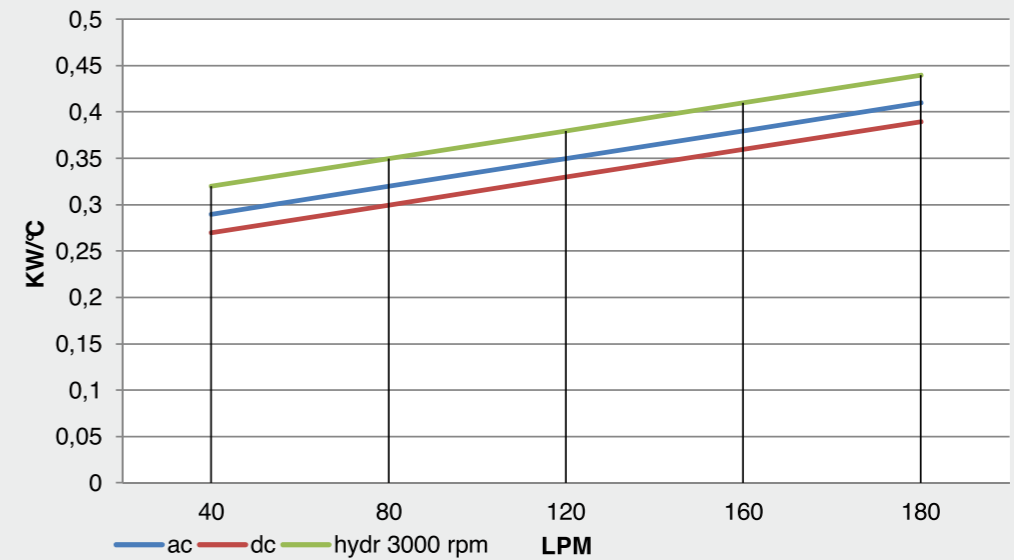

**DIAGRAMMA PERDITE DI CARICO - PRESSURE DROP DIAGRAM**

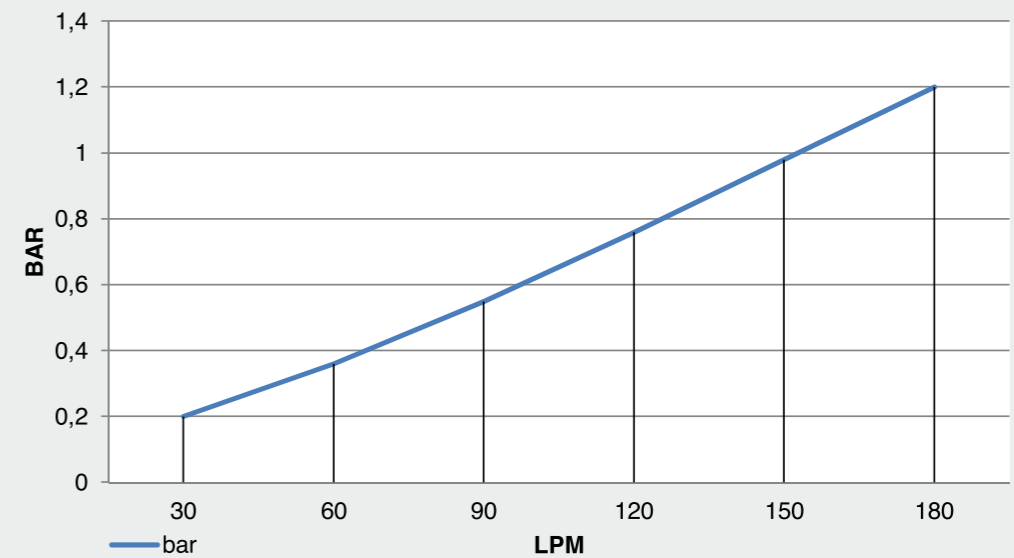

Portata olio - Oil flow: 40-180 lt/1'



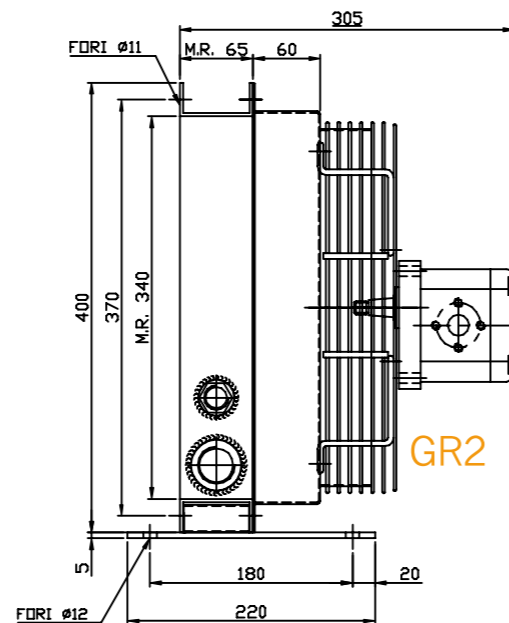
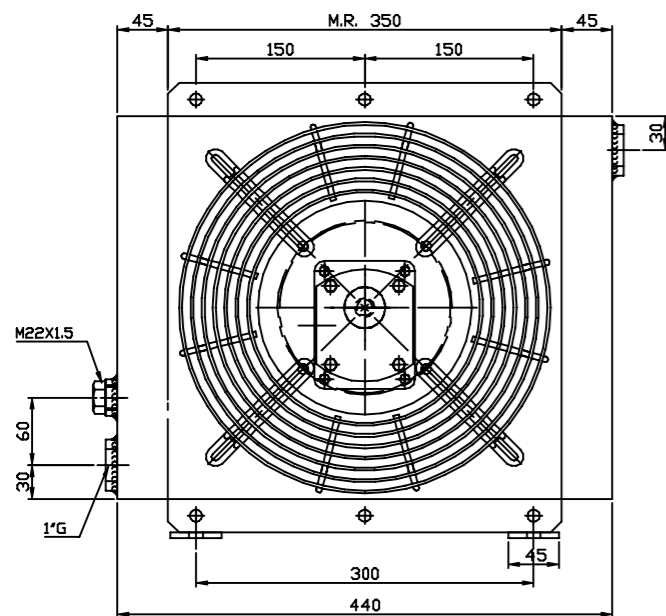
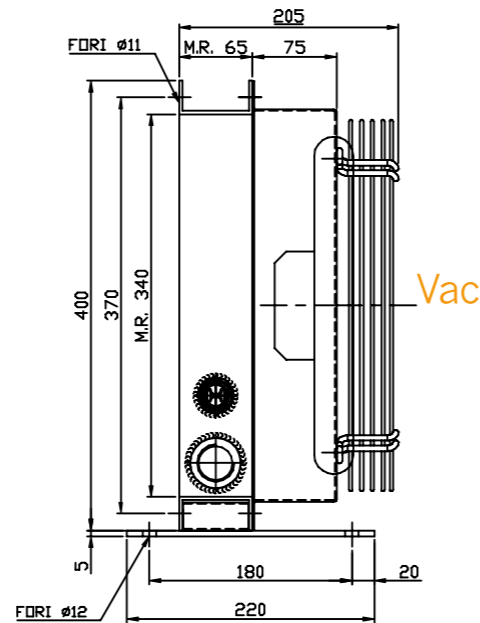
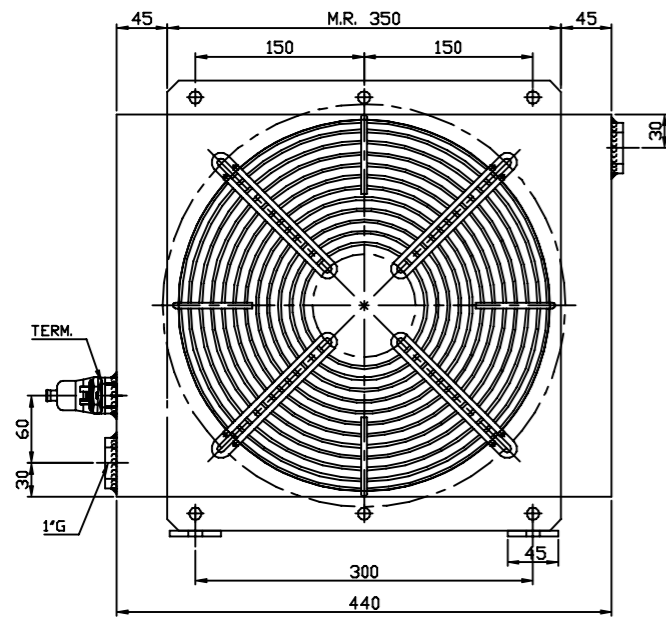
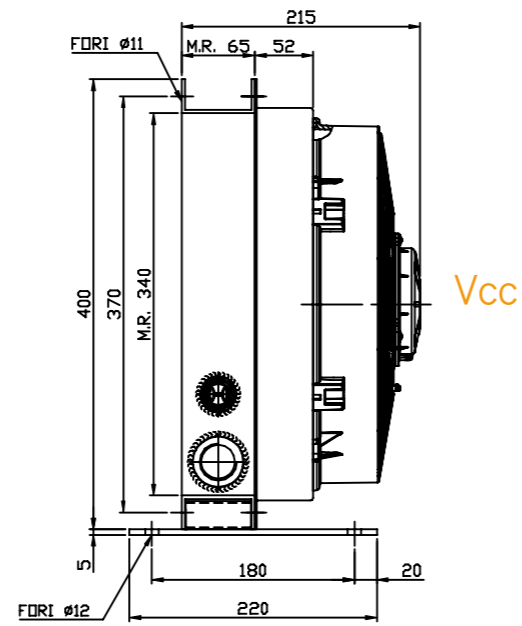
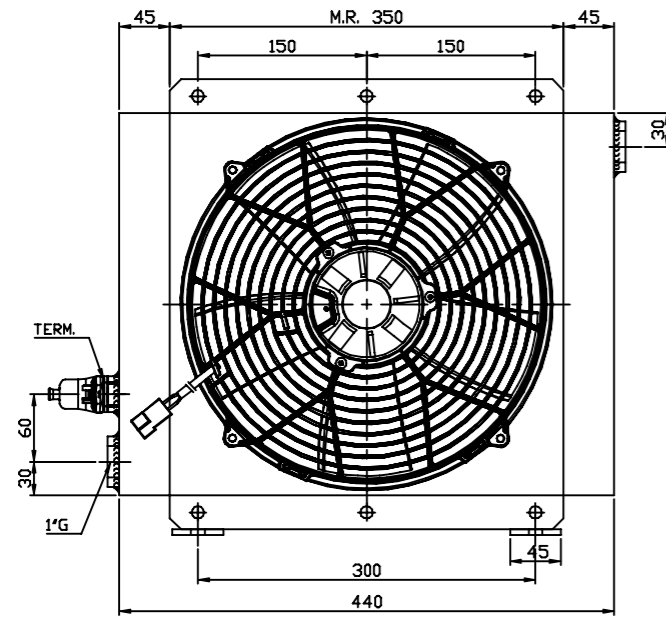

**DATI TECNICI - TECHNICAL DATA**

TENSIONE VOLTAGE	ASSORBIMENTO CURRENT	PORTATA ARIA AIR FLOW	PROTEZIONE PROTECTION	Ø
V	A	m <sup>3</sup> /h	IP	mm
12	20,7	2490	68	305
24	10	2520	68	305
230 Hz 50/60	1,1/ 1,55	3410 / 3740	44	300
230/400 Hz 50/60	0,62-0,36 / 0,83-0,48	3130 / 3350	44	300
Predisposizione GR2 - Prepared for GR2			/	310

**DIAGRAMMA DI RENDIMENTO - PERFORMANCE DIAGRAM**

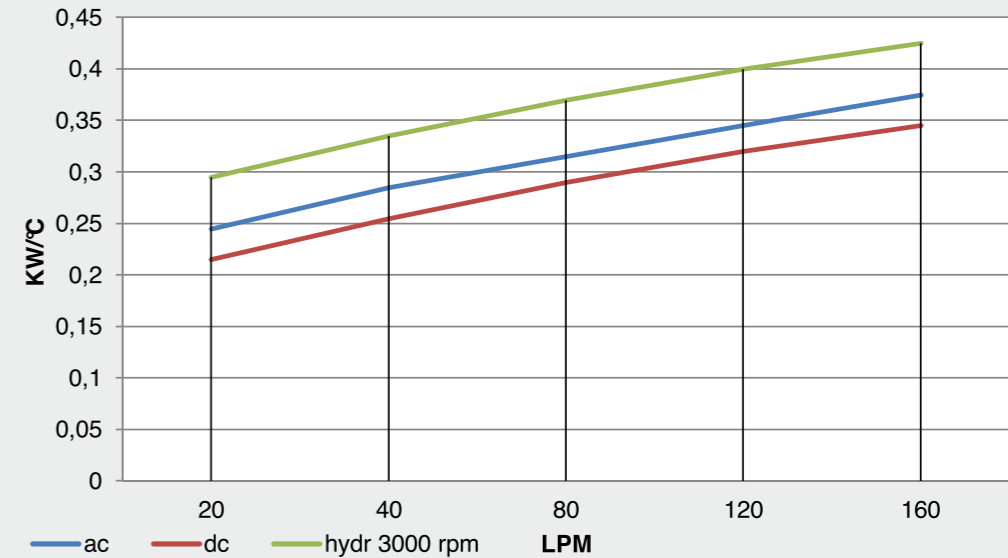

**DIAGRAMMA PERDITE DI CARICO - PRESSURE DROP DIAGRAM**

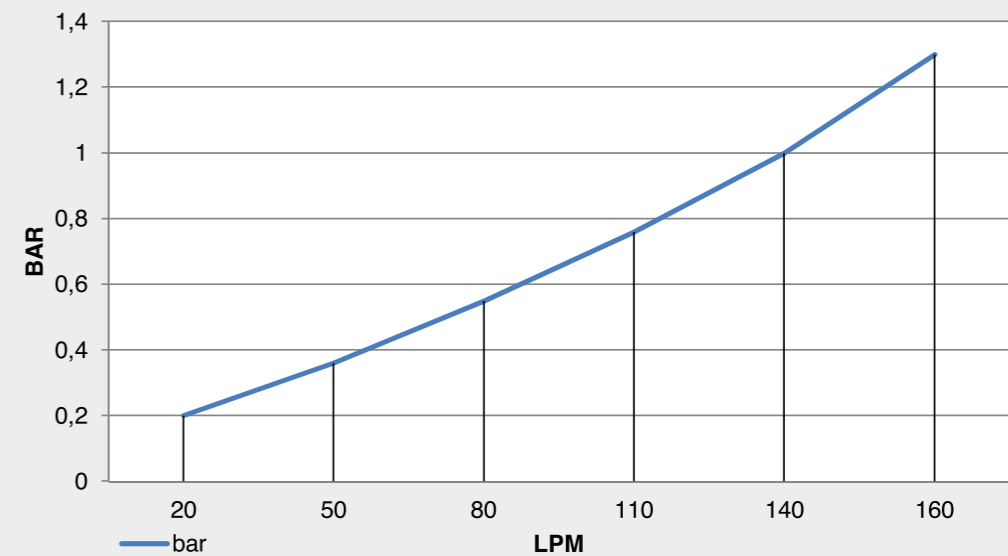

Portata olio - Oil flow: 20-160 lt/1'

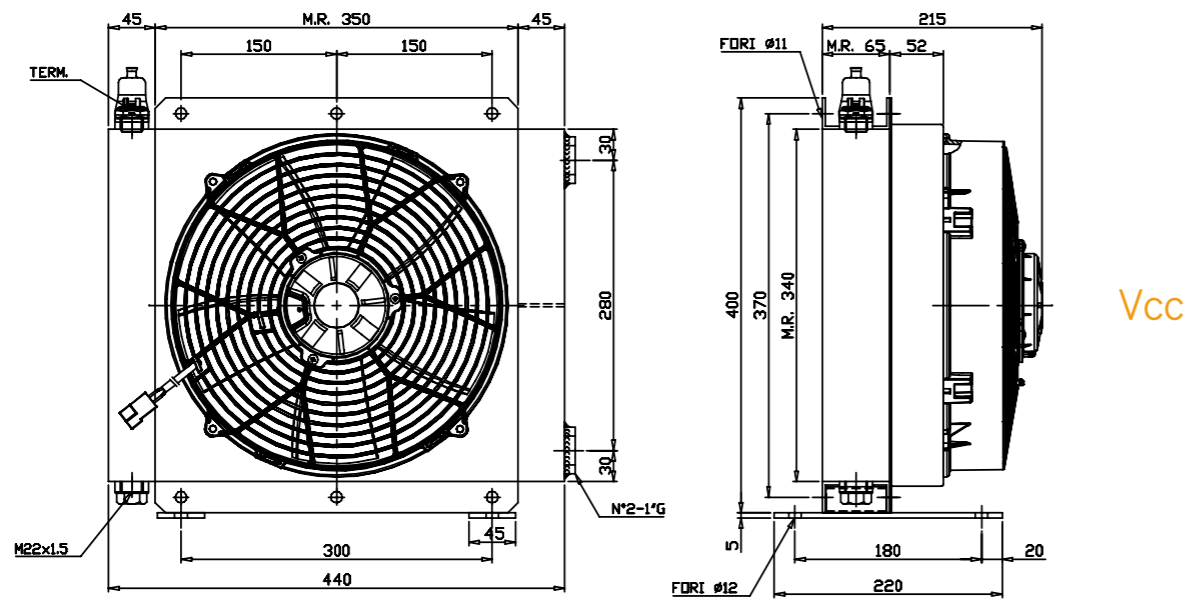

Vcc

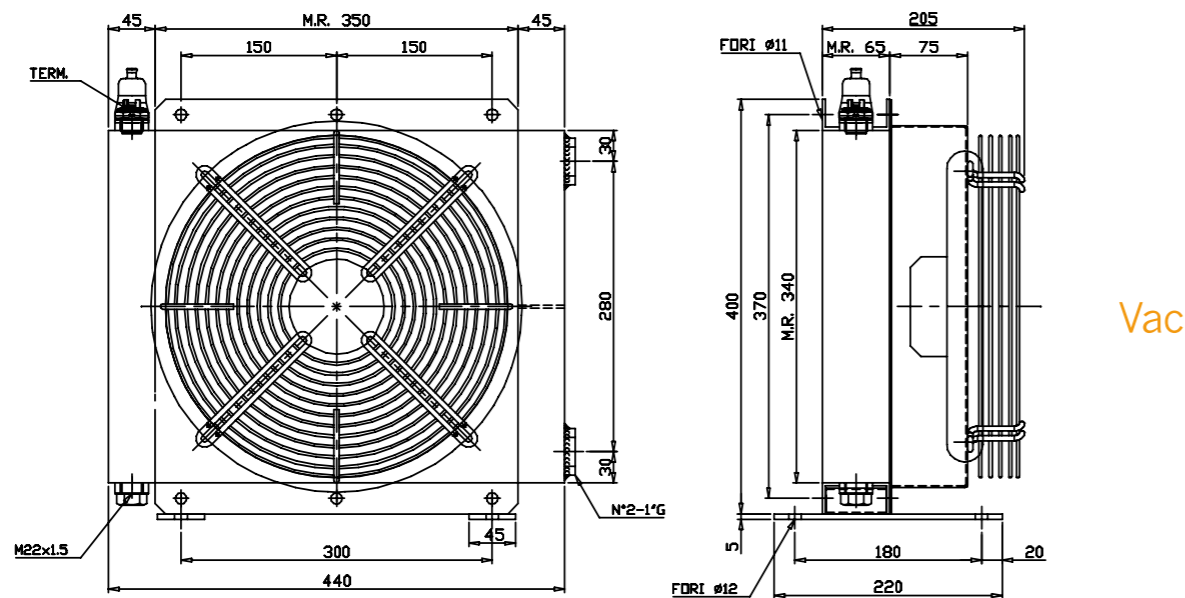

Vac

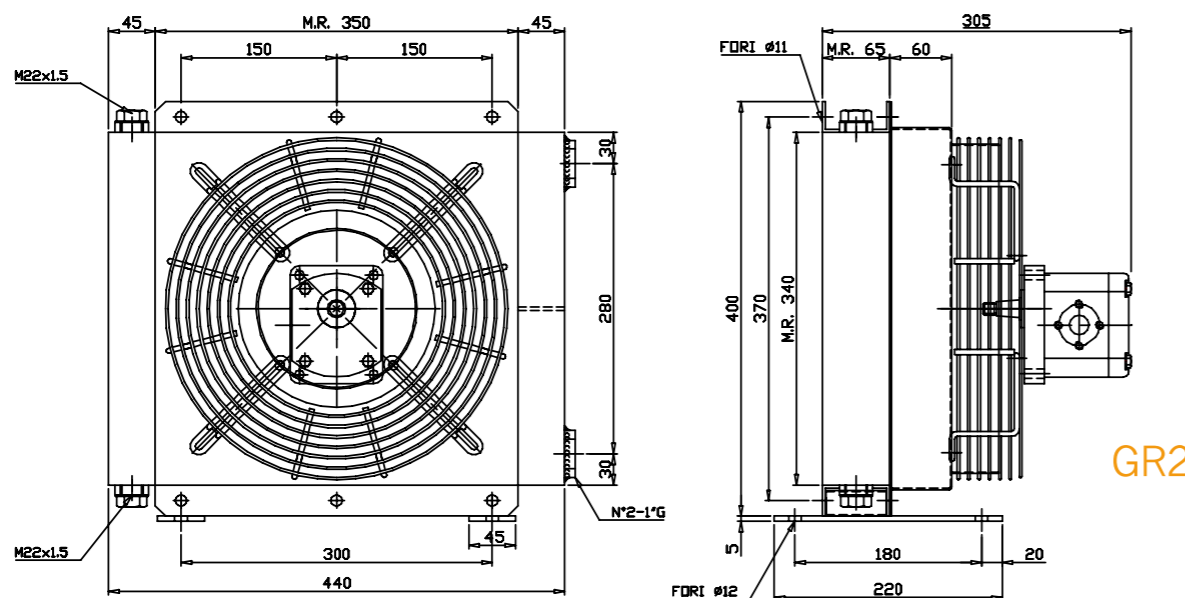

GR2

**DATI TECNICI - TECHNICAL DATA**

TENSIONE VOLTAGE	ASSORBIMENTO CURRENT	PORTATA ARIA AIR FLOW	PROTEZIONE PROTECTION	Ø
V	A	m <sup>3</sup> /h	IP	mm
12	20,7	2490	68	305
24	10	2520	68	305
230 Hz 50/60	1,1/ 1,55	3410 / 3740	44	300
230/400 Hz 50/60	0,62-0,36 / 0,83-0,48	3130 / 3350	44	300
Predisposizione GR2 - Prepared for GR2			/	310

**DIAGRAMMA DI RENDIMENTO - PERFORMANCE DIAGRAM**

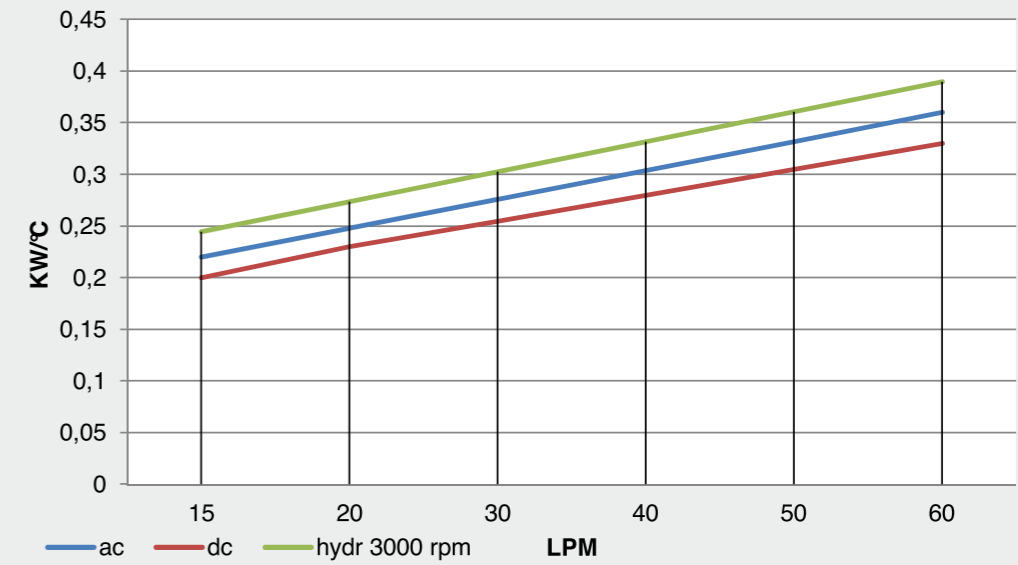

**DIAGRAMMA PERDITE DI CARICO - PRESSURE DROP DIAGRAM**

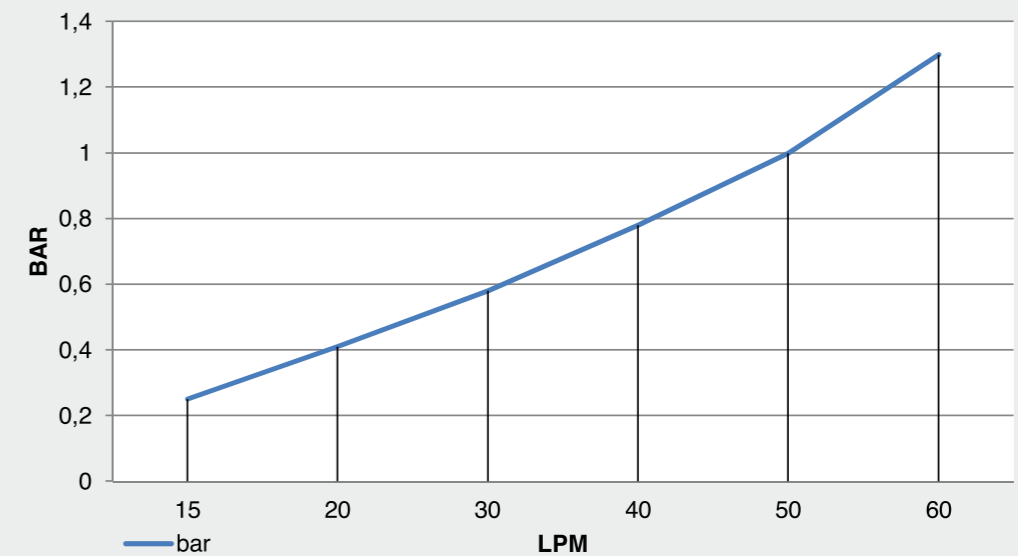

Portata olio - Oil flow: 15-60 lt/1'

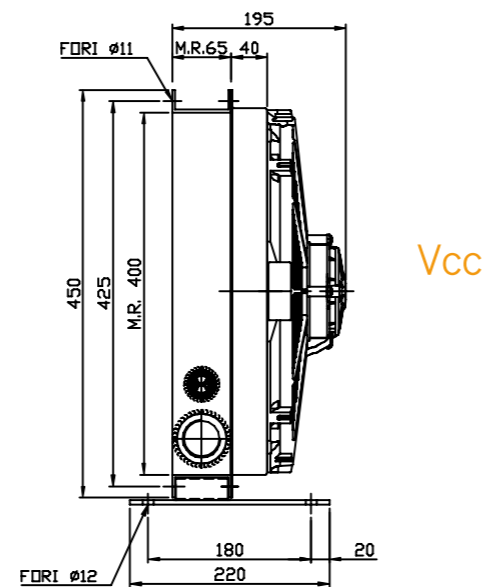
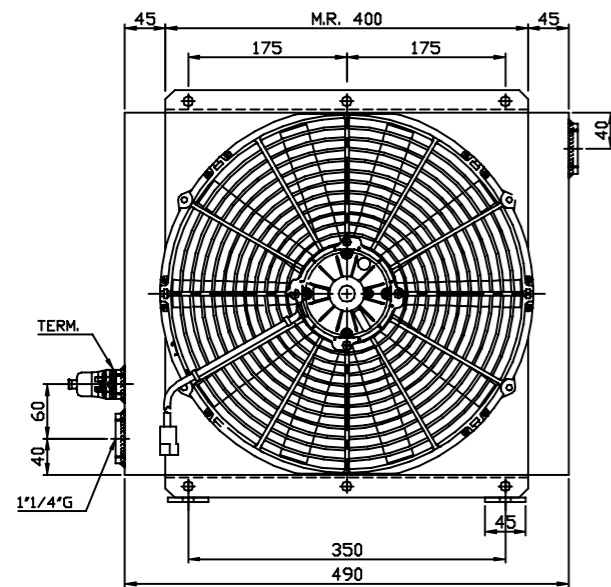

Vcc

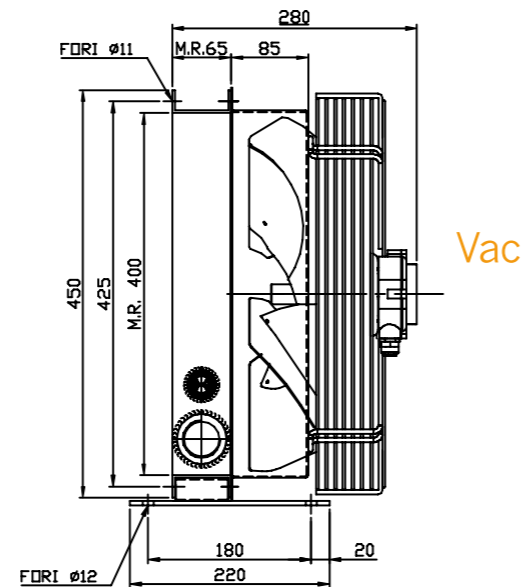
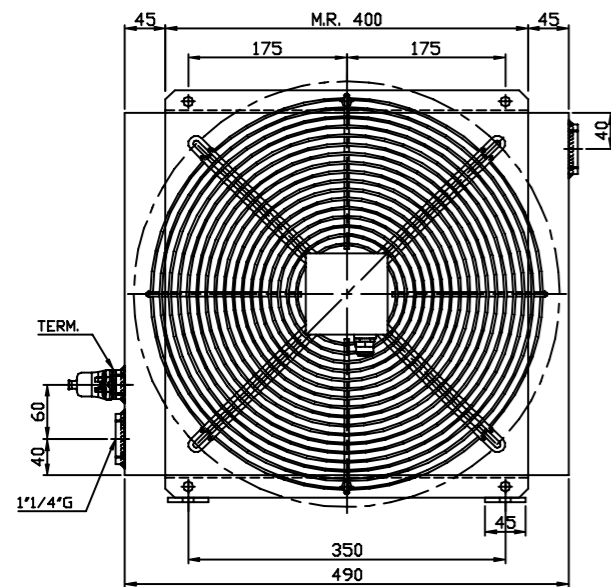

Vac

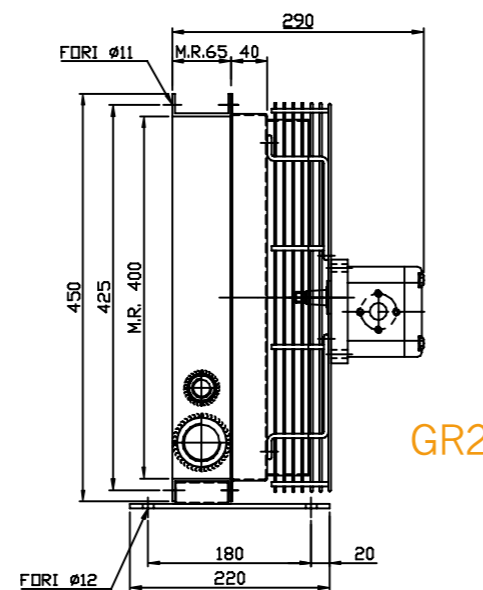
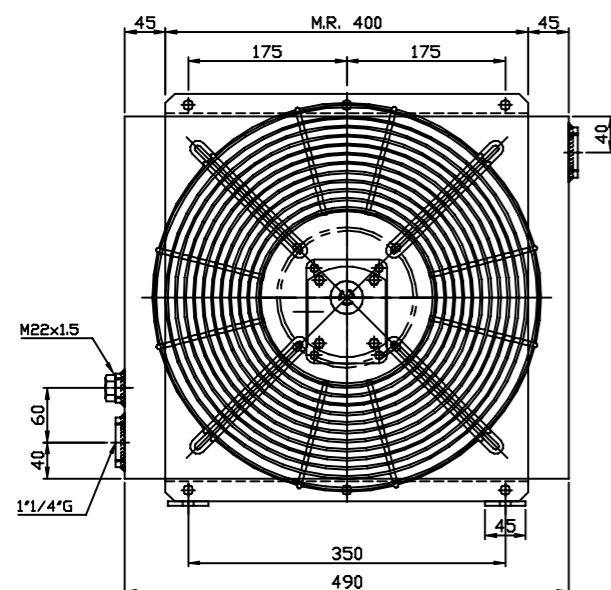

GR2

**DATI TECNICI - TECHNICAL DATA**

TENSIONE VOLTAGE	ASSORBIMENTO CURRENT	PORTATA ARIA AIR FLOW	PROTEZIONE PROTECTION	Ø
V	A	m <sup>3</sup> /h	IP	mm
12	18,1	3220	68	385
24	8	3080	68	385
230 Hz 50/60	0,73/ 1,06	4235 / 4950	44	400
230/400 Hz 50/60	0,76-0,44 / 0,68-0,39	4000 / 4610	44	400
Predisposizione GR2 - Prepared for GR2			/	380

**DIAGRAMMA DI RENDIMENTO - PERFORMANCE DIAGRAM**

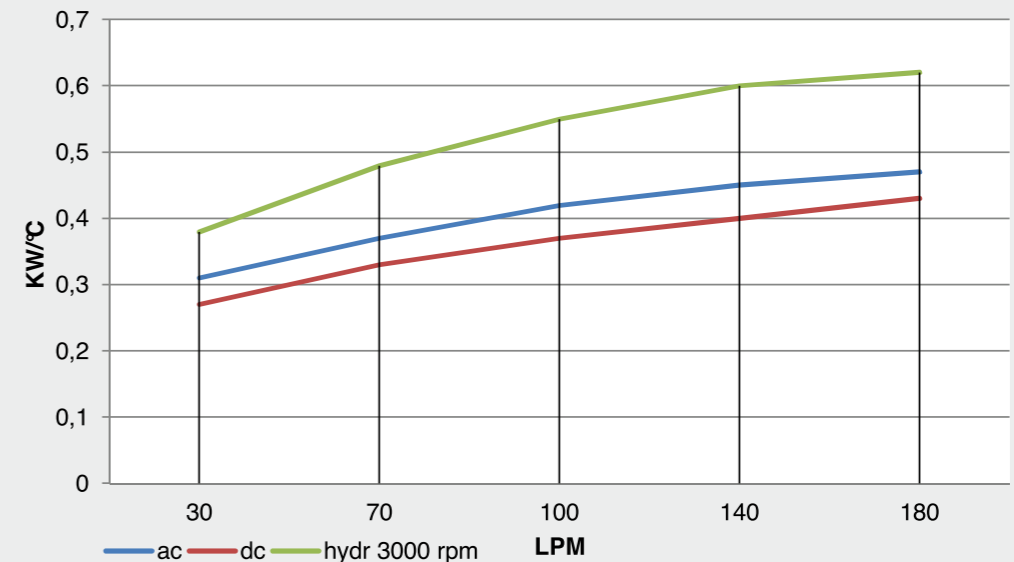

**DIAGRAMMA PERDITE DI CARICO - PRESSURE DROP DIAGRAM**

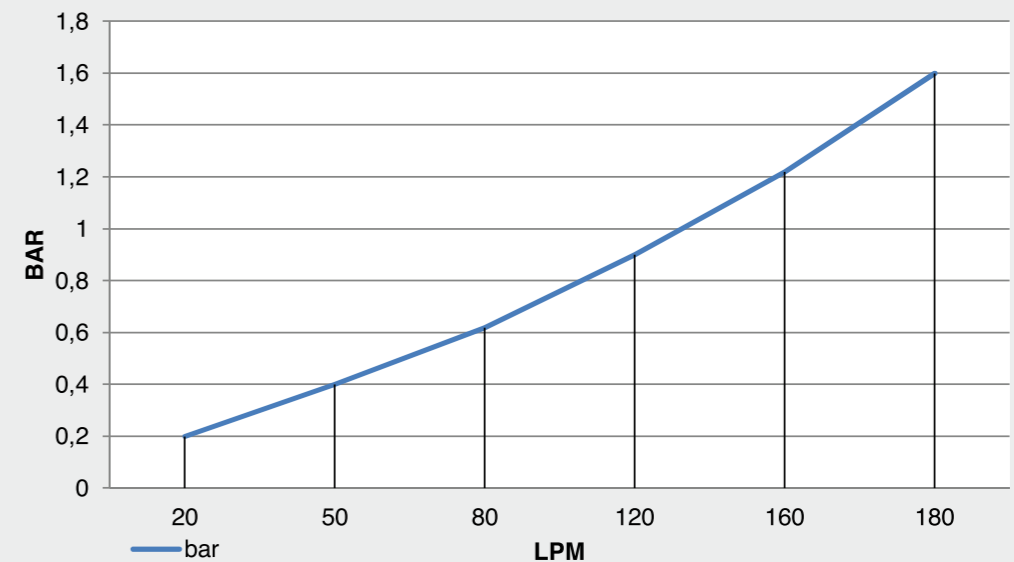

Portata olio - Oil flow: 30-180 lt/1'

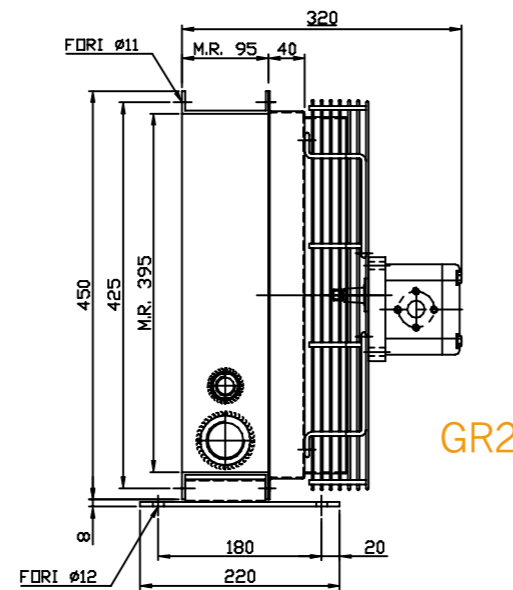
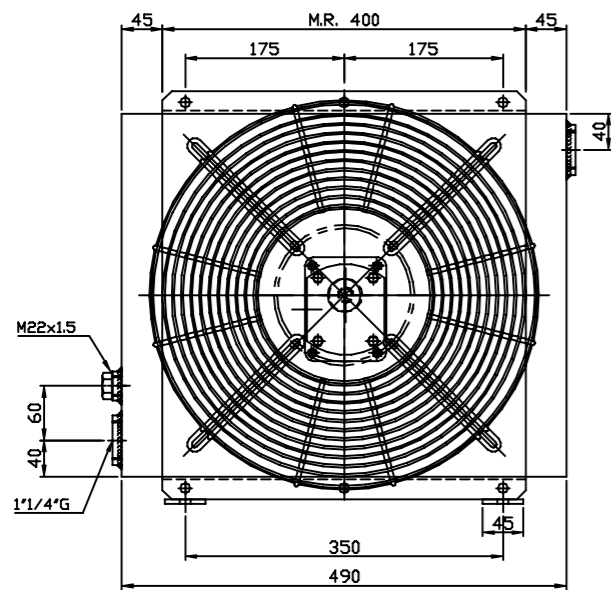
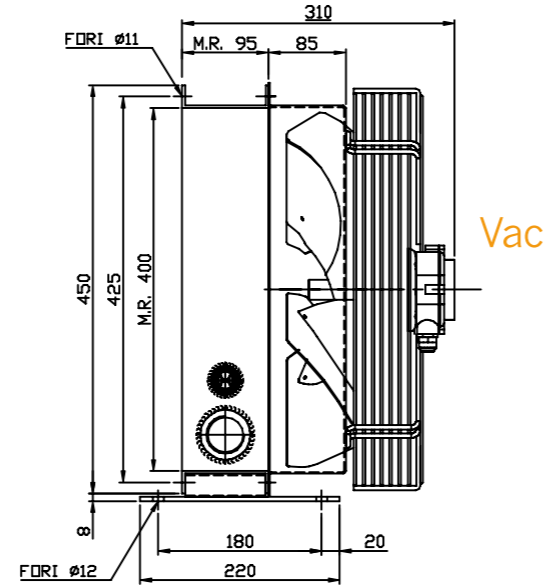
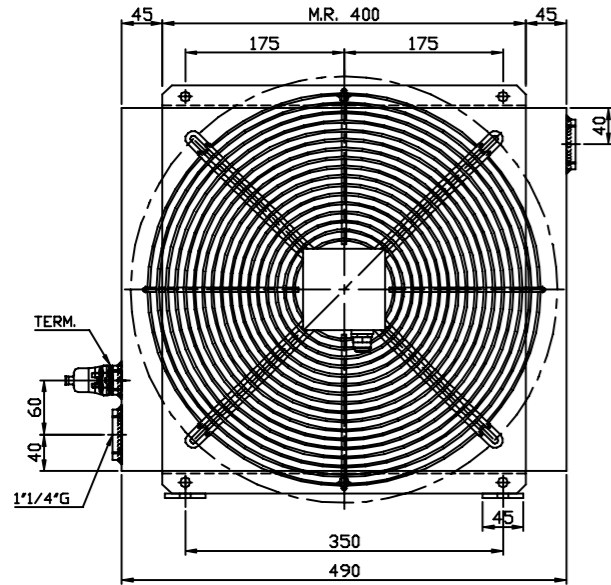
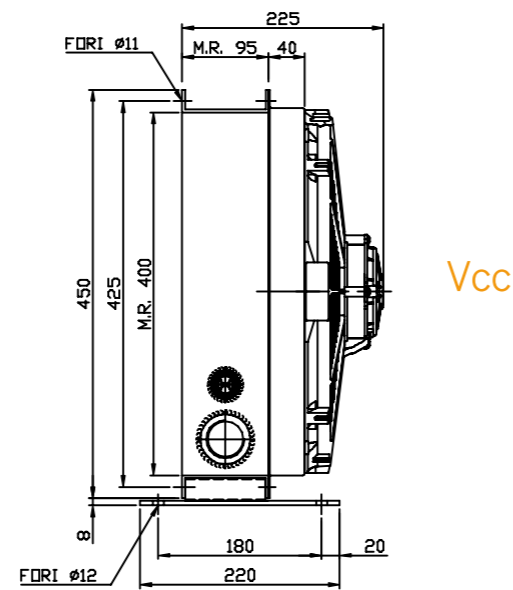
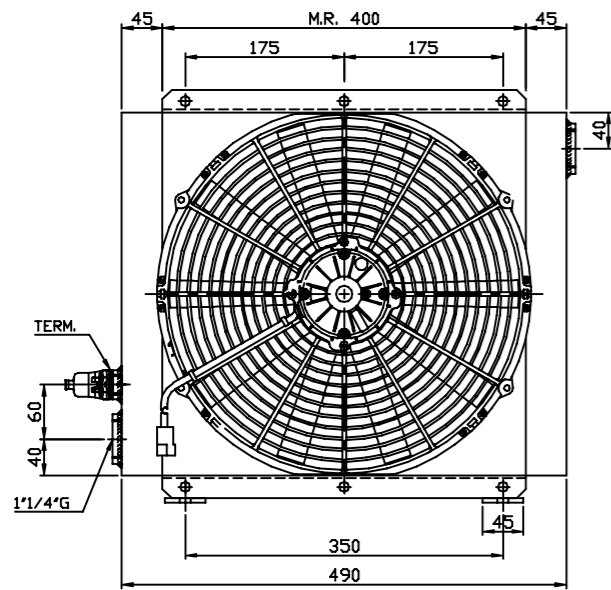

**DATI TECNICI - TECHNICAL DATA**

TENSIONE VOLTAGE	ASSORBIMENTO CURRENT	PORTATA ARIA AIR FLOW	PROTEZIONE PROTECTION	Ø
V	A	m <sup>3</sup> /h	IP	mm
12	18,1	3220	68	385
24	8	3080	68	385
230 Hz 50/60	0,73/ 1,06	4235 / 4950	44	400
230/400 Hz 50/60	0,76-0,44 / 0,68-0,39	4000 / 4610	44	400
Predisposizione GR2 - Prepared for GR2			/	380

**DIAGRAMMA DI RENDIMENTO - PERFORMANCE DIAGRAM**

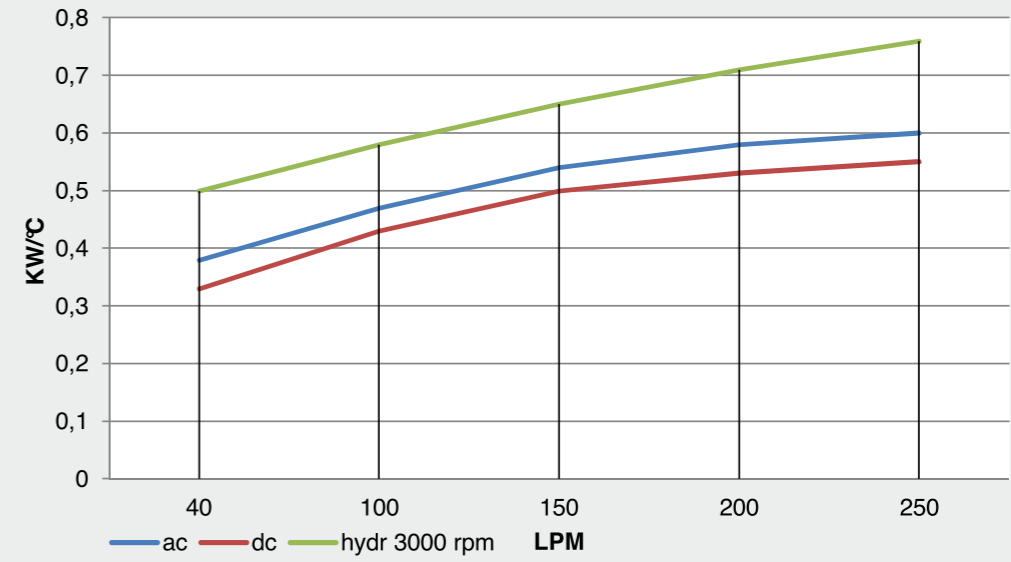

**DIAGRAMMA PERDITE DI CARICO - PRESSURE DROP DIAGRAM**

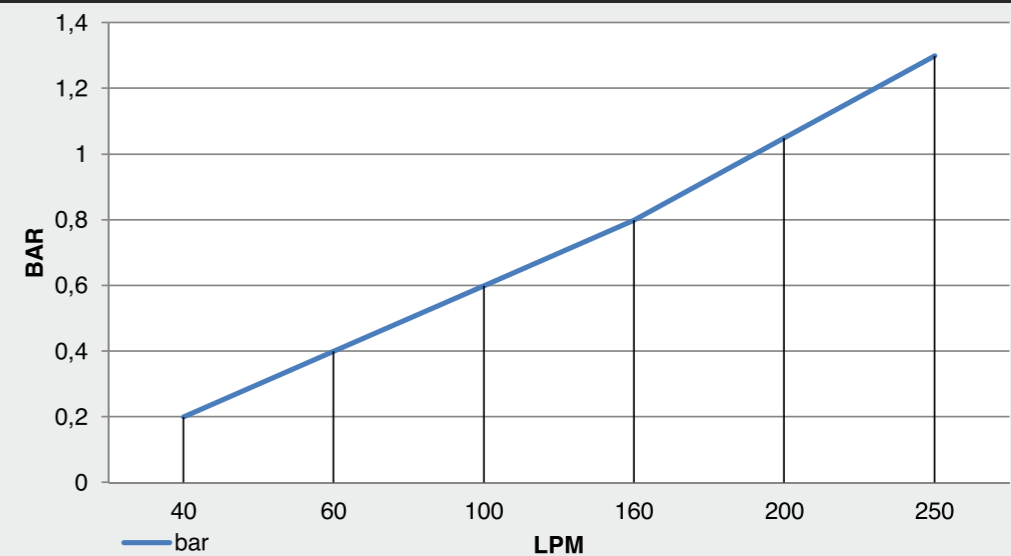

Portata olio - Oil flow: 40-250 lt/1'

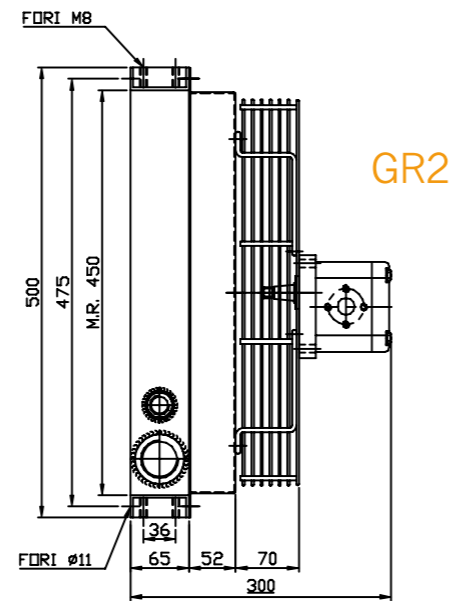
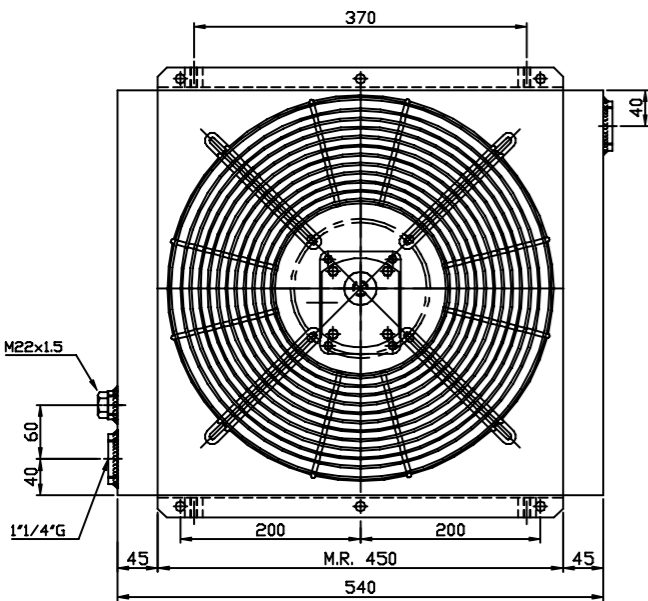
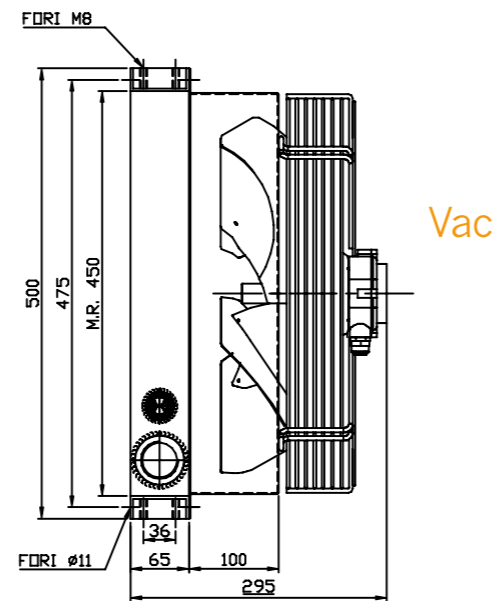
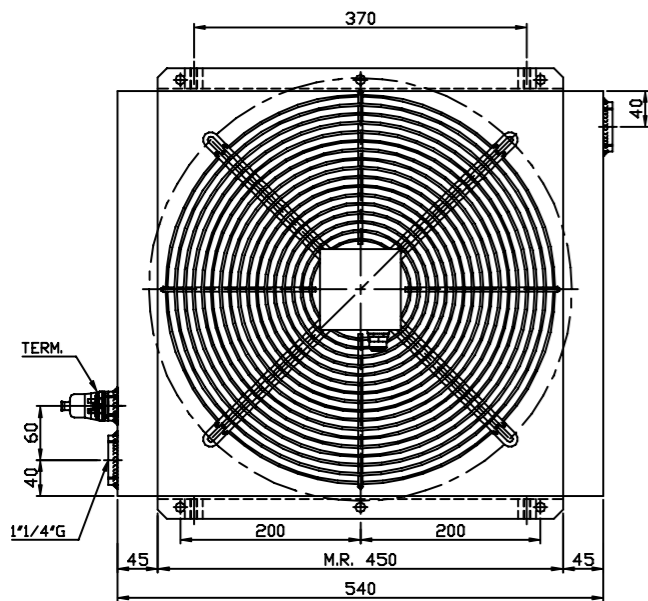
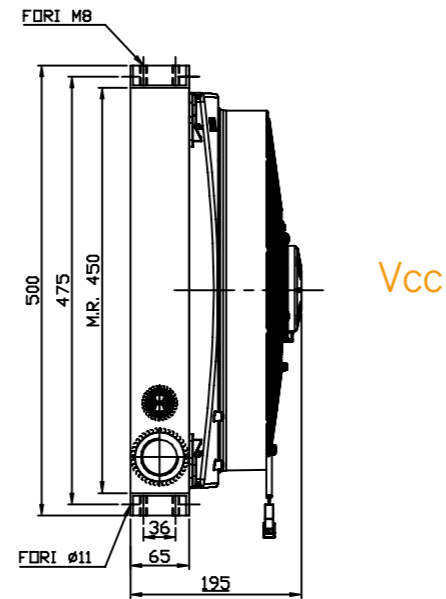
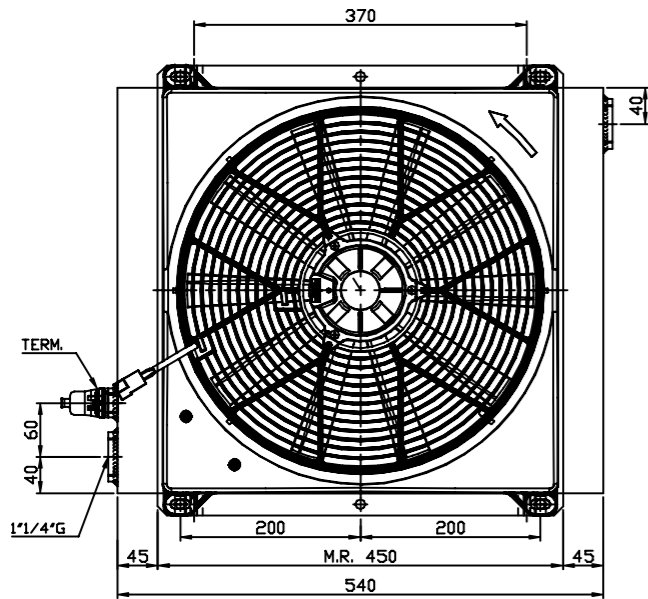

**DATI TECNICI - TECHNICAL DATA**

TENSIONE VOLTAGE	ASSORBIMENTO CURRENT	PORTATA ARIA AIR FLOW	PROTEZIONE PROTECTION	Ø
V	A	m <sup>3</sup> /h	IP	mm
12	18,1	3220	68	385
24	8	3080	68	385
230 Hz 50/60	0,73/ 1,06	4235 / 4950	44	400
230/400 Hz 50/60	0,76-0,44 / 0,68-0,39	4000 / 4610	44	400
Predisposizione GR2 - Prepared for GR2			/	400

**DIAGRAMMA DI RENDIMENTO - PERFORMANCE DIAGRAM**

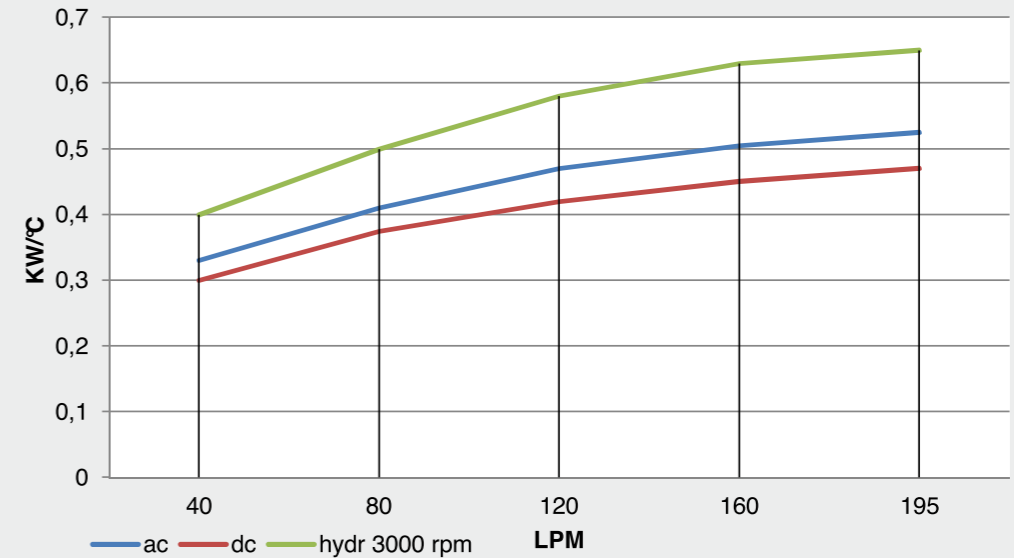

**DIAGRAMMA PERDITE DI CARICO - PRESSURE DROP DIAGRAM**

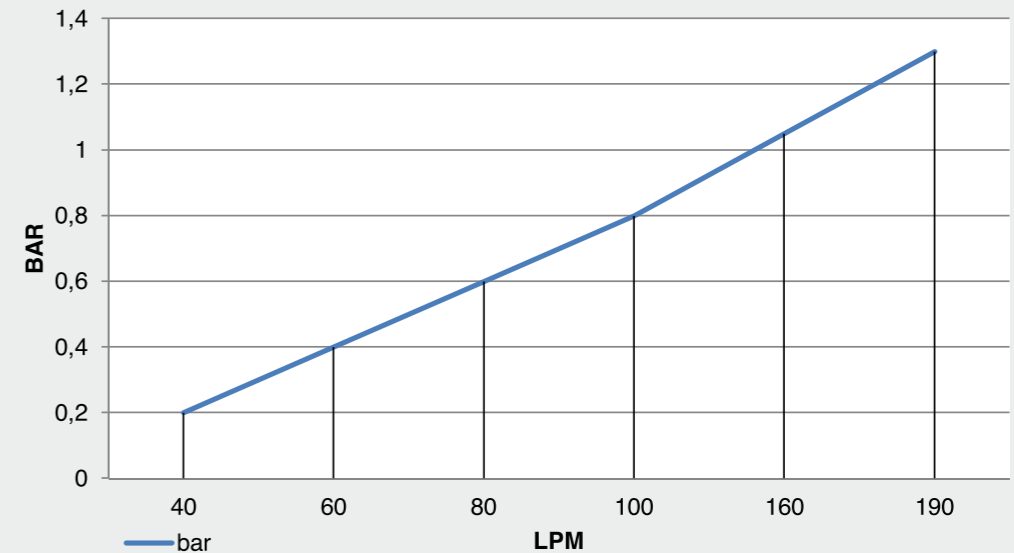

Portata olio - Oil flow: 40-195 lt/1'

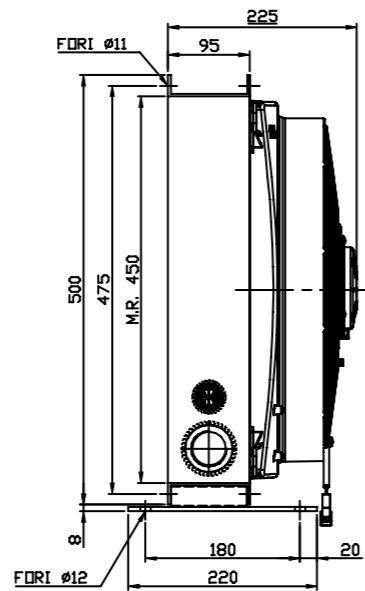
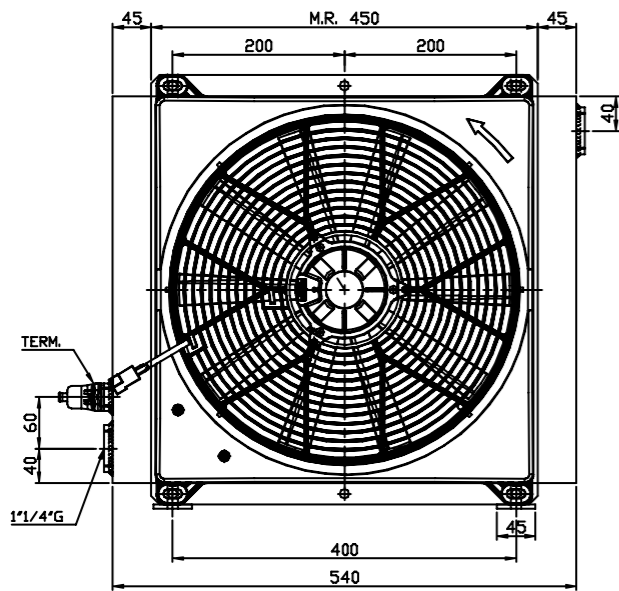

Vcc

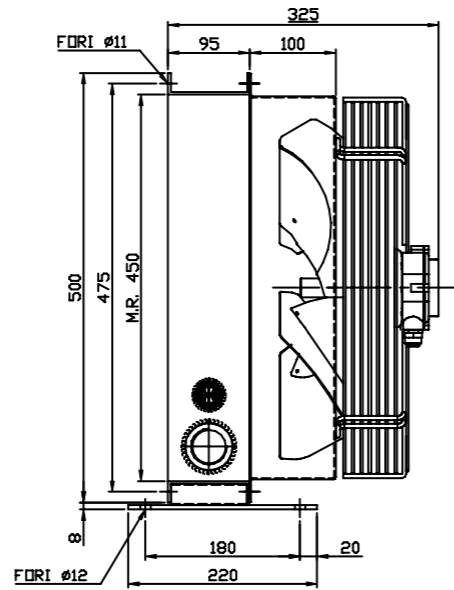
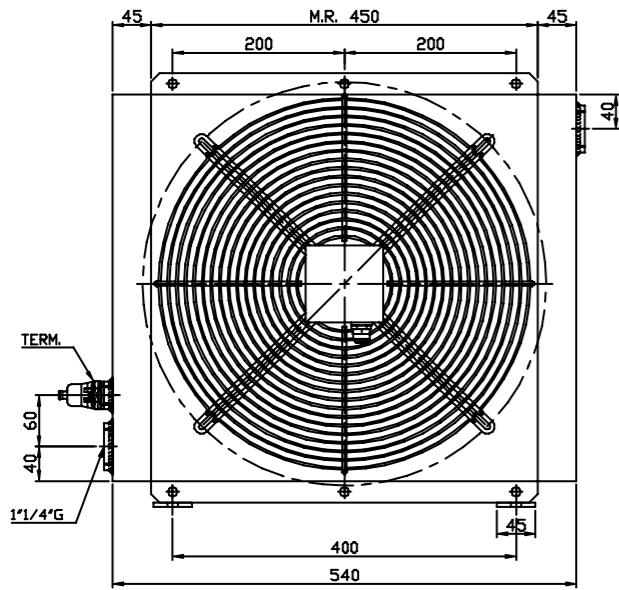

Vac

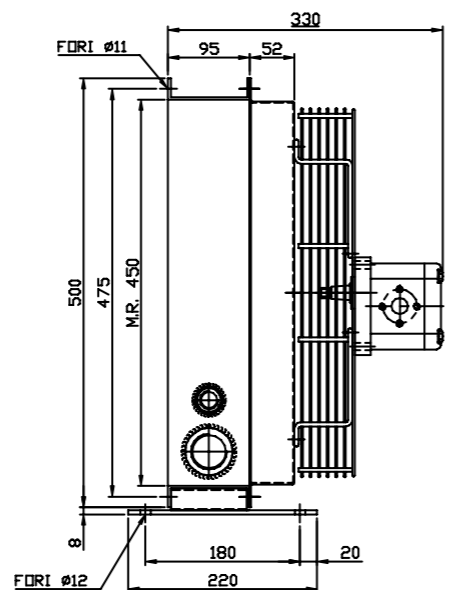
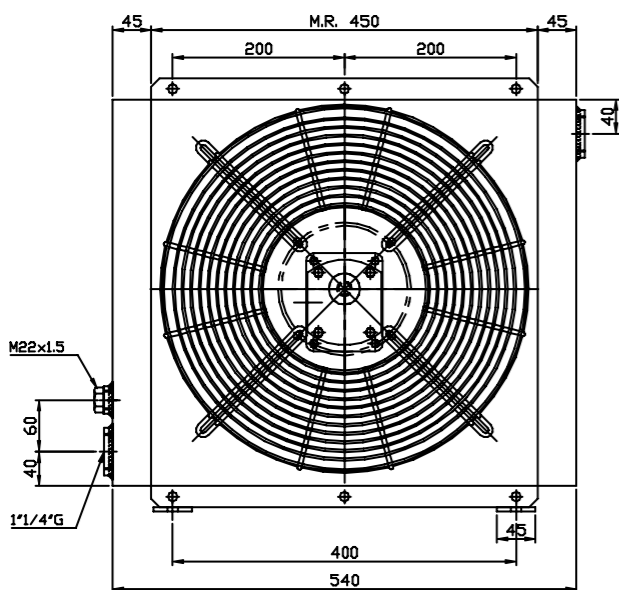

GR2

**DATI TECNICI - TECHNICAL DATA**

TENSIONE VOLTAGE	ASSORBIMENTO CURRENT	PORTATA ARIA AIR FLOW	PROTEZIONE PROTECTION	Ø
V	A	m <sup>3</sup> /h	IP	mm
12	18,1	3220	68	385
24	8	3080	68	385
230 Hz 50/60	0,73/ 1,06	4235 / 4950	44	400
230/400 Hz 50/60	0,76-0,44 / 0,68-0,39	4000 / 4610	44	400
Predisposizione GR2 - Prepared for GR2				400

**DIAGRAMMA DI RENDIMENTO - PERFORMANCE DIAGRAM**

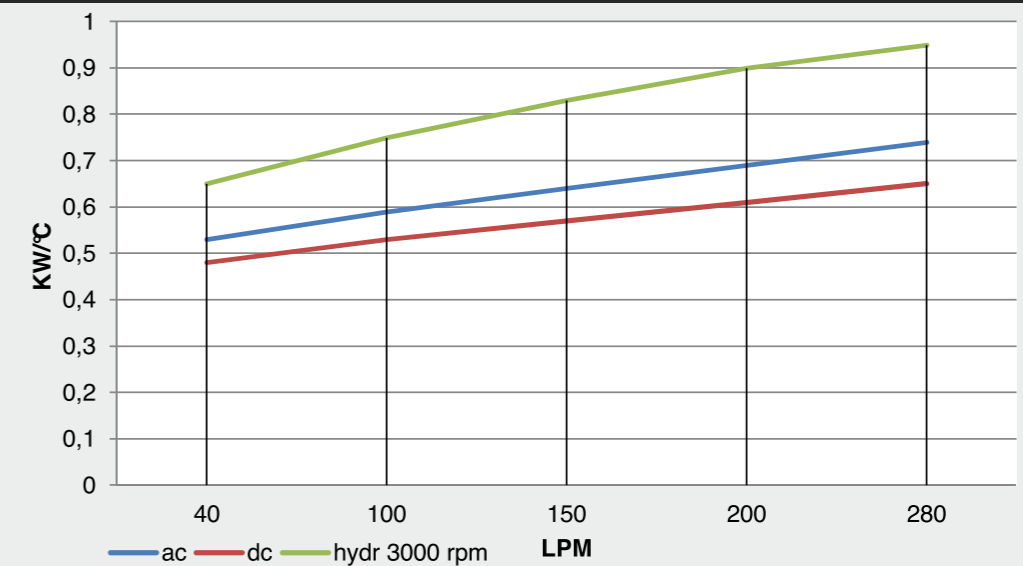

**DIAGRAMMA PERDITE DI CARICO - PRESSURE DROP DIAGRAM**

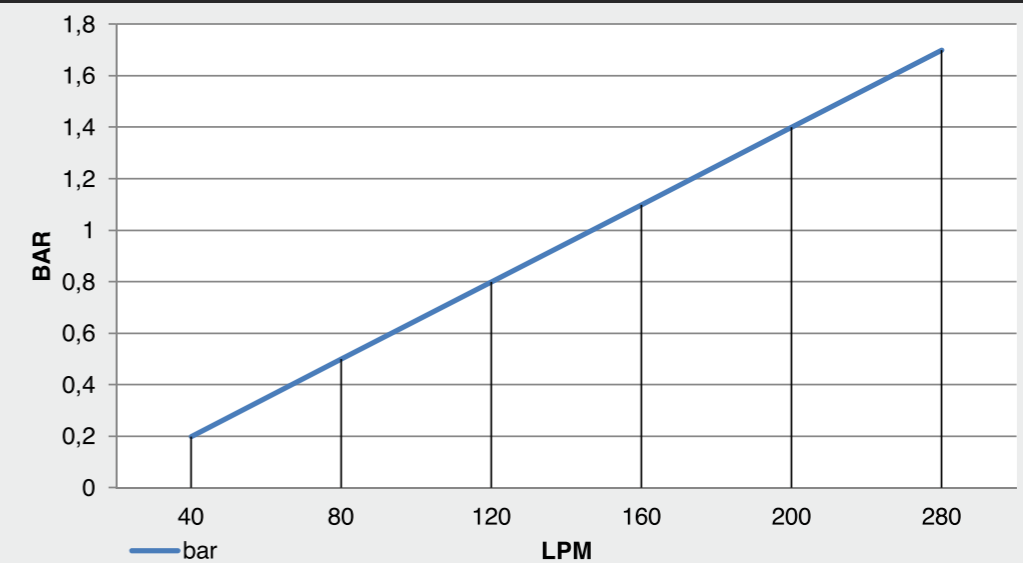

Portata olio - Oil flow: 40-280 lt/1'

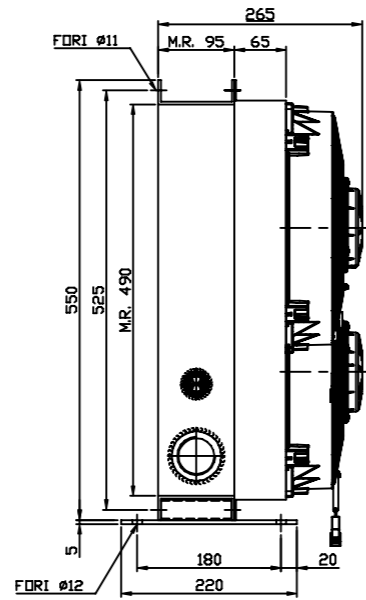
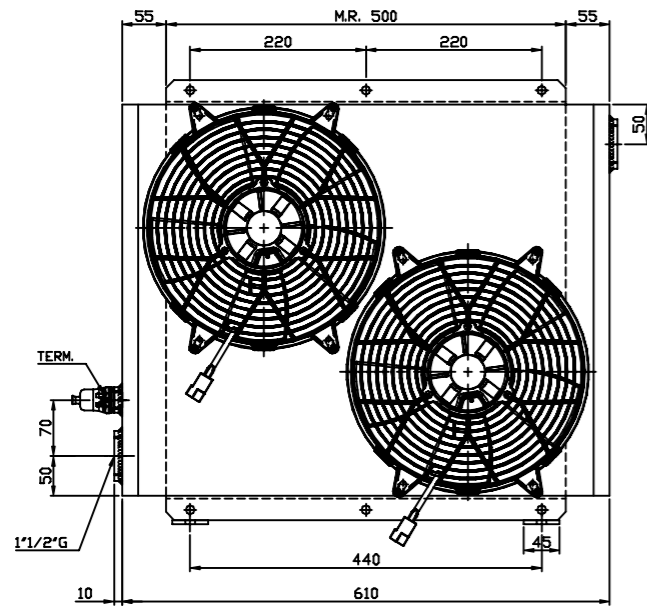

Vcc

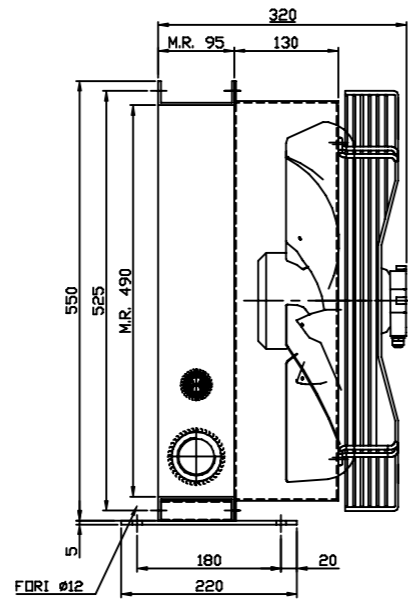
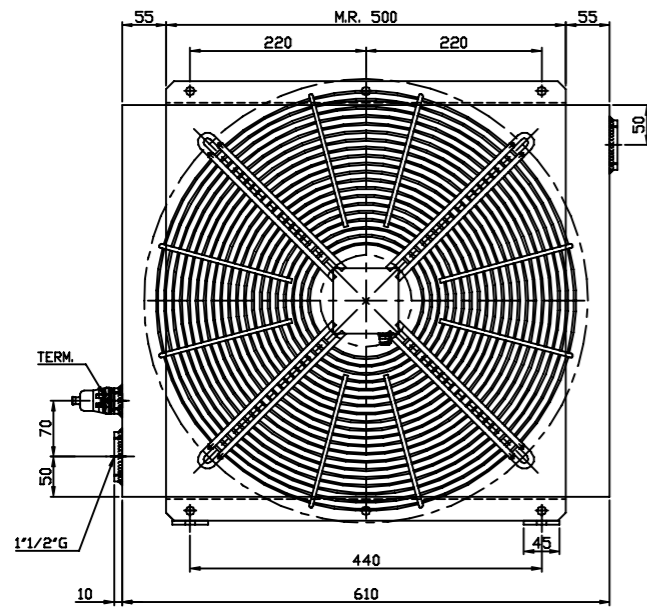

Vac

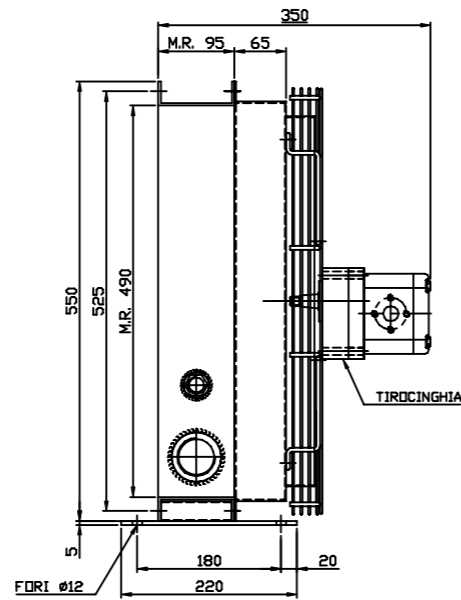
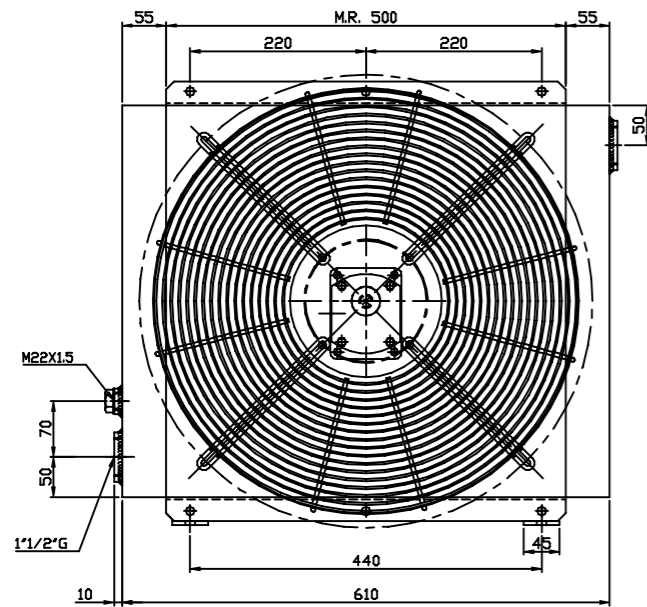

GR2

**DATI TECNICI - TECHNICAL DATA**

TENSIONE VOLTAGE	ASSORBIMENTO CURRENT	PORTATA ARIA AIR FLOW	PROTEZIONE PROTECTION	Ø
V	A	m <sup>3</sup> /h	IP	mm
12	16,6 x 2	2010 x 2	68	280 x 2
24	8 x 2	2010 x 2	68	280 x 2
230 Hz 50/60	2,36/ 2,96	6300	54	450
400/480 Hz 50/60	0,98 / 1,20	6300	54	450
Predisposizione GR2 - Prepared for GR2			/	450

**DIAGRAMMA DI RENDIMENTO - PERFORMANCE DIAGRAM**

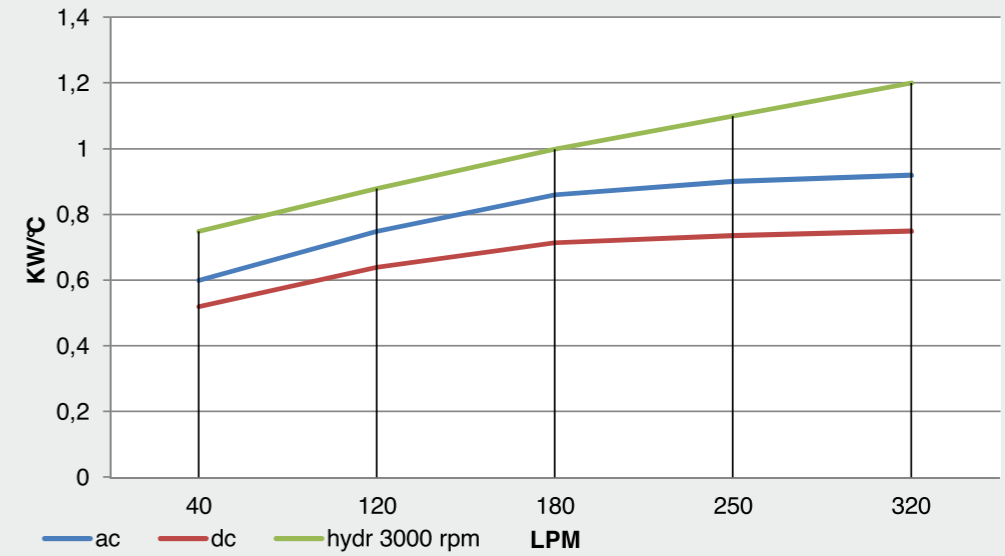

**DIAGRAMMA PERDITE DI CARICO - PRESSURE DROP DIAGRAM**

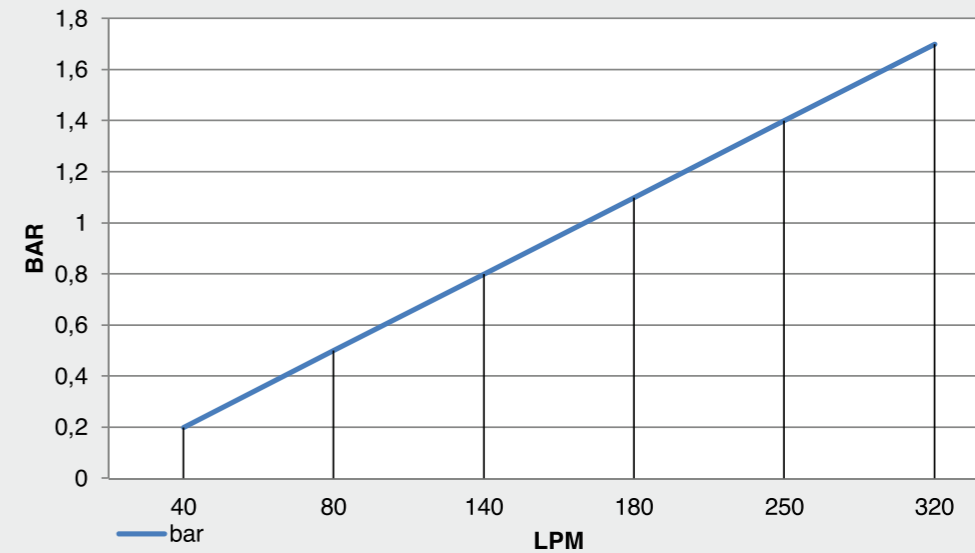

Portata olio - Oil flow: 40-320 lt/1'

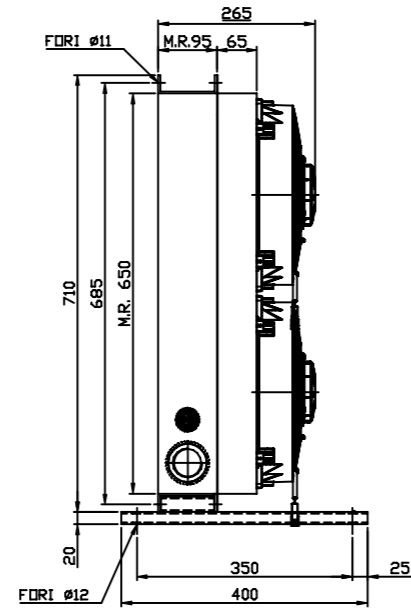
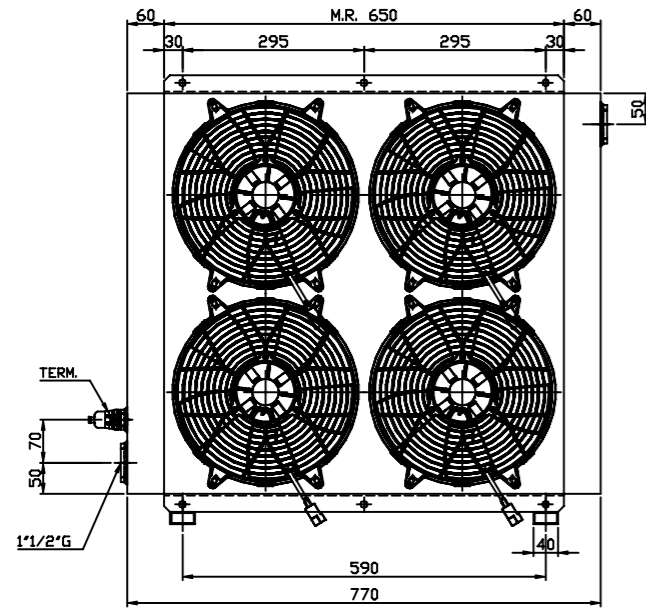

Vcc

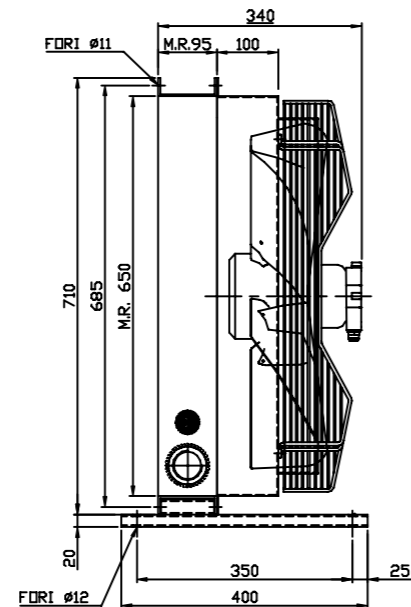
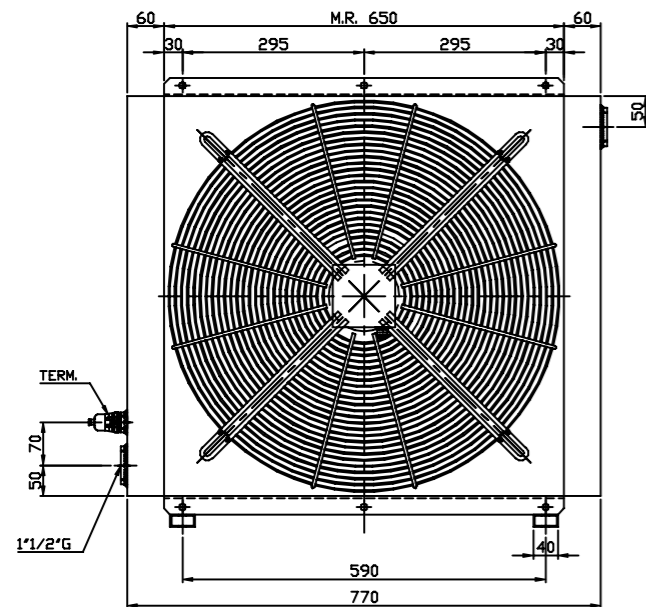

Vac

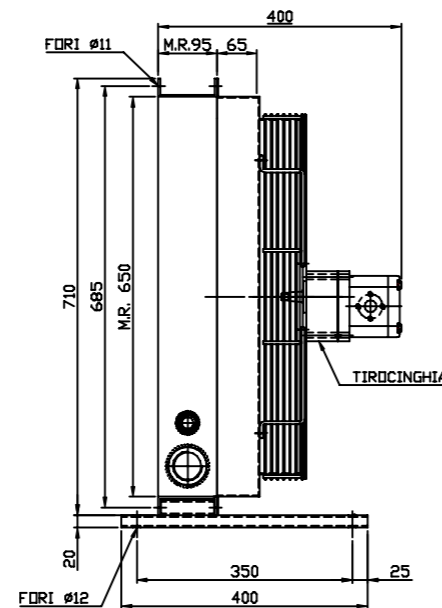
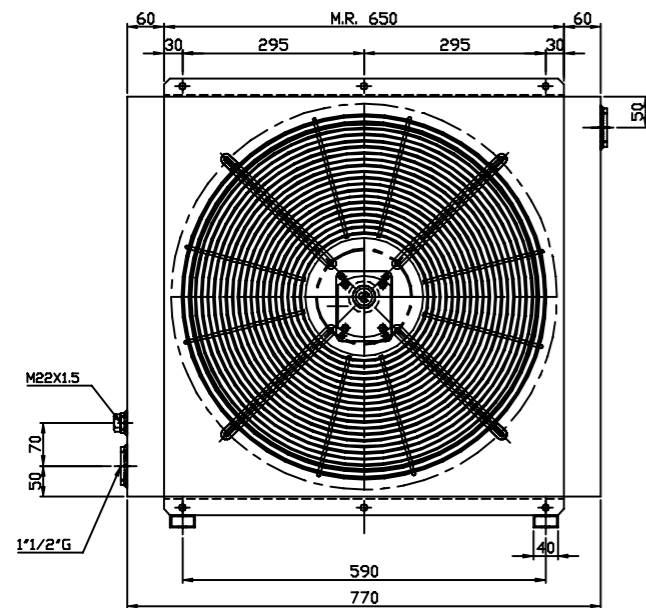

GR2

**DATI TECNICI - TECHNICAL DATA**

TENSIONE VOLTAGE	ASSORBIMENTO CURRENT	PORTATA ARIA AIR FLOW	PROTEZIONE PROTECTION	Ø
V	A	m <sup>3</sup> /h	IP	mm
12	16,6 x 4	2010 x 4	68	280 x 4
24	8 x 4	2010 x 4	68	280 x 4
230 Hz 50/60	4,15	10470	54	560
400/480 Hz 50/60	1,32 / 1,60	8910 / 10350	54	560
Predisposizione GR2 - Prepared for GR2			/	560

**DIAGRAMMA DI RENDIMENTO - PERFORMANCE DIAGRAM**

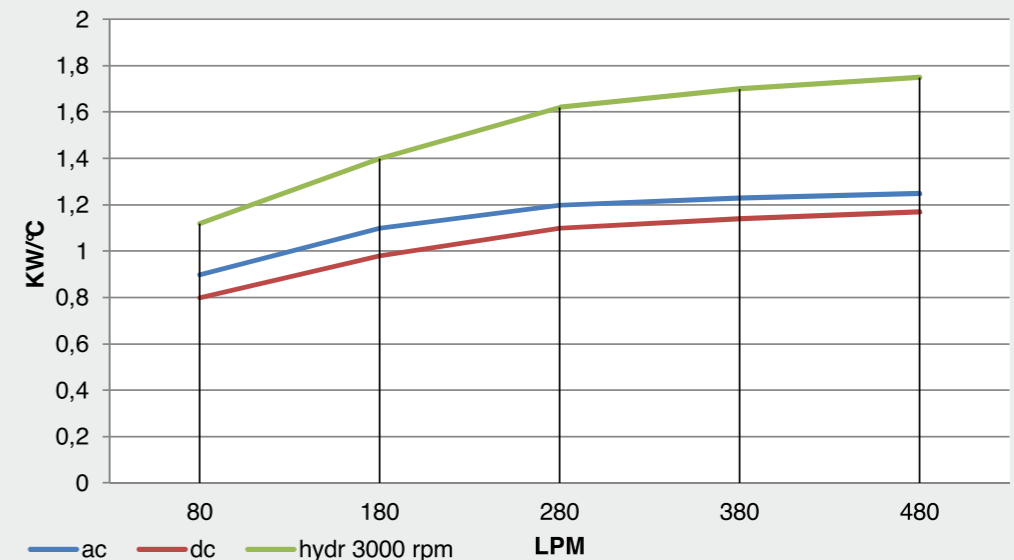

**DIAGRAMMA PERDITE DI CARICO - PRESSURE DROP DIAGRAM**

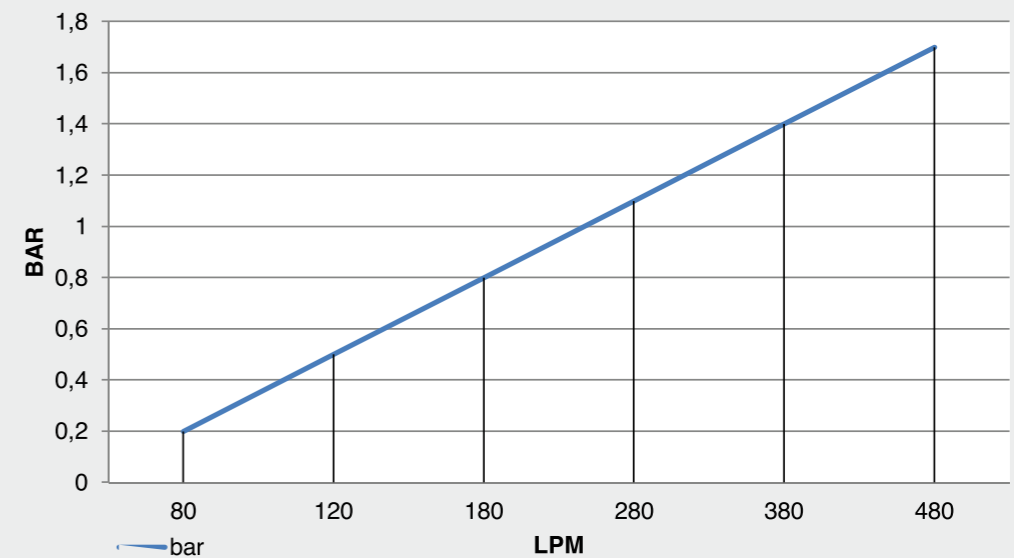

Portata olio - Oil flow: 80-480 lt/1'



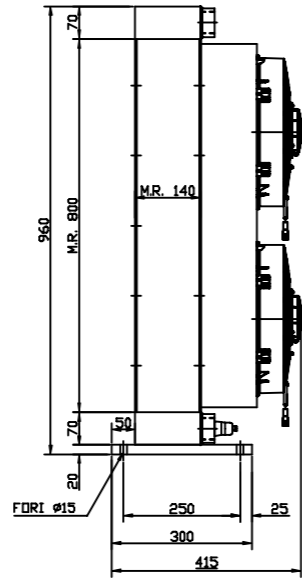
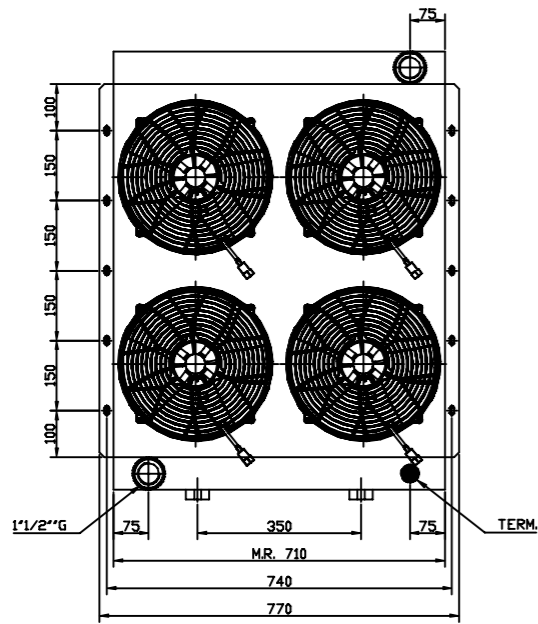

Vcc

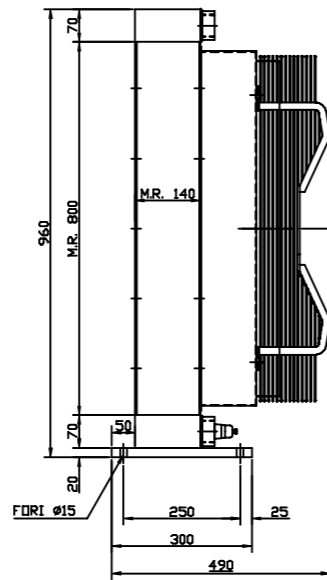
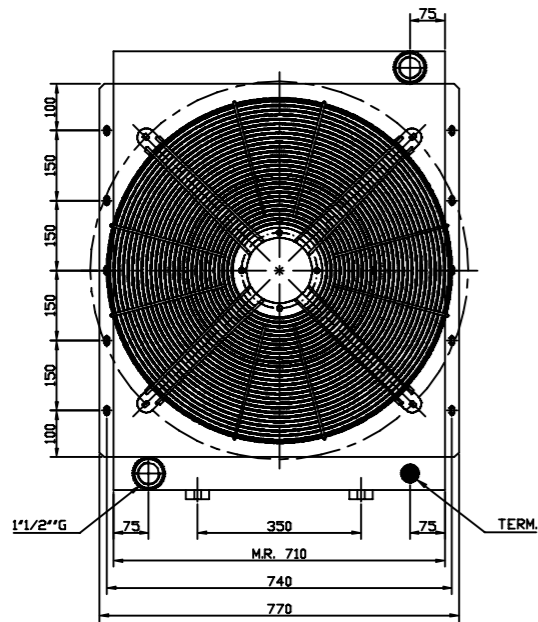

Vac

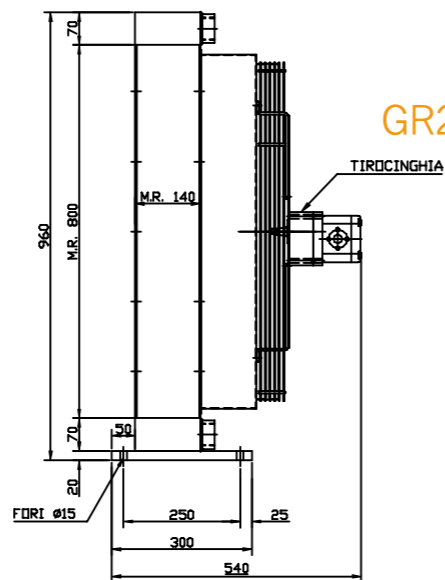
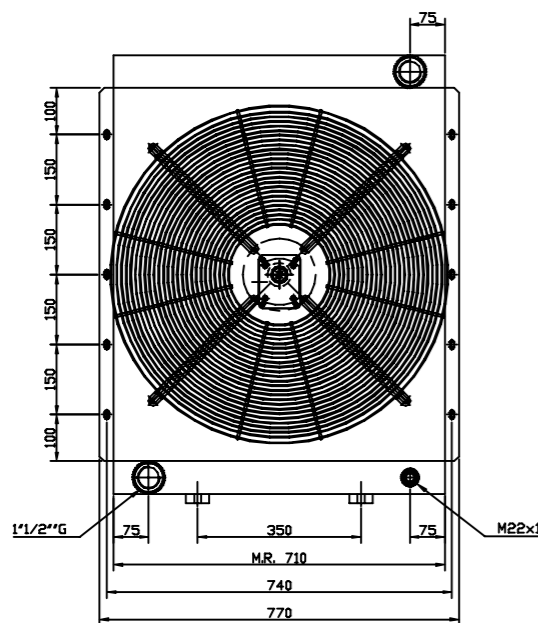

GR2

**DATI TECNICI - TECHNICAL DATA**

TENSIONE VOLTAGE	ASSORBIMENTO CURRENT	PORTATA ARIA AIR FLOW	PROTEZIONE PROTECTION	Ø
V	A	m <sup>3</sup> /h	IP	mm
12	20,7	2490 x 4	68	305 x 4
24	10	2520 x 4	68	305 x 4
230 Hz 50/60	3,9	11000	55	710
400/480 Hz 50/60	2,35 / 2,87	13950 / 17000	54	710
Predisposizione GR2 - Prepared for GR2			/	700

**DIAGRAMMA DI RENDIMENTO - PERFORMANCE DIAGRAM**

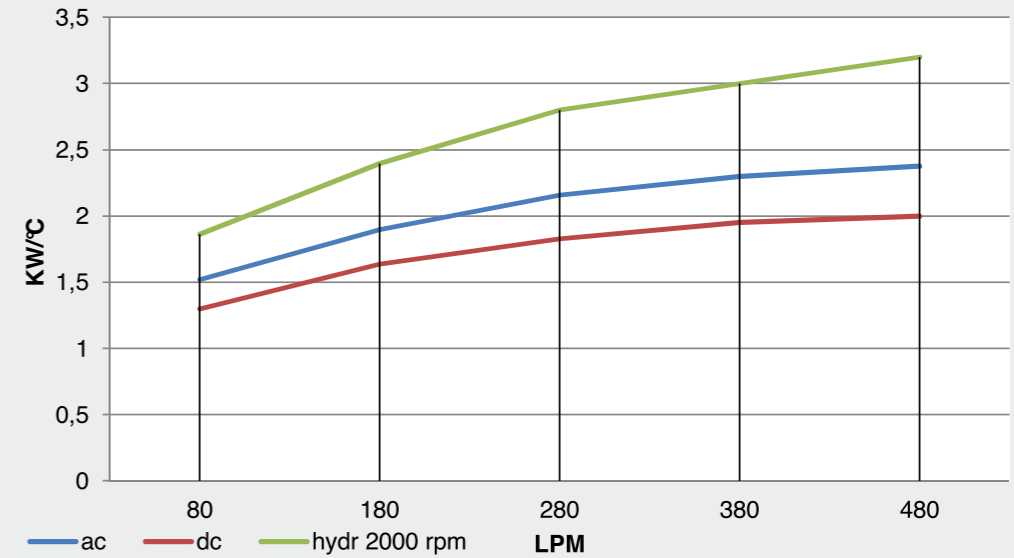

**DIAGRAMMA PERDITE DI CARICO - PRESSURE DROP DIAGRAM**

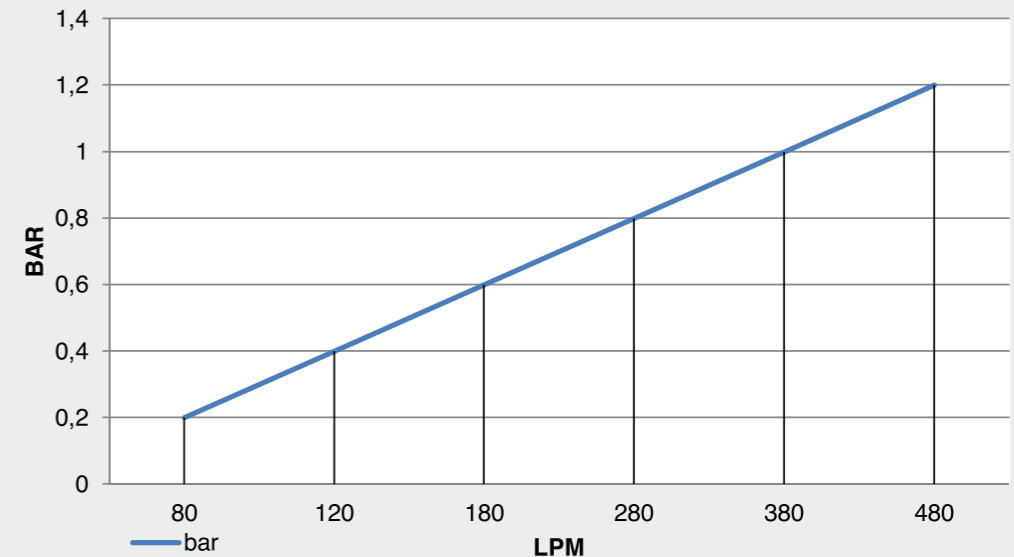

Portata olio - Oil flow: 80-480 lt/1'

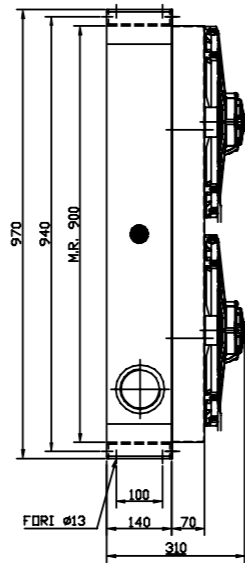
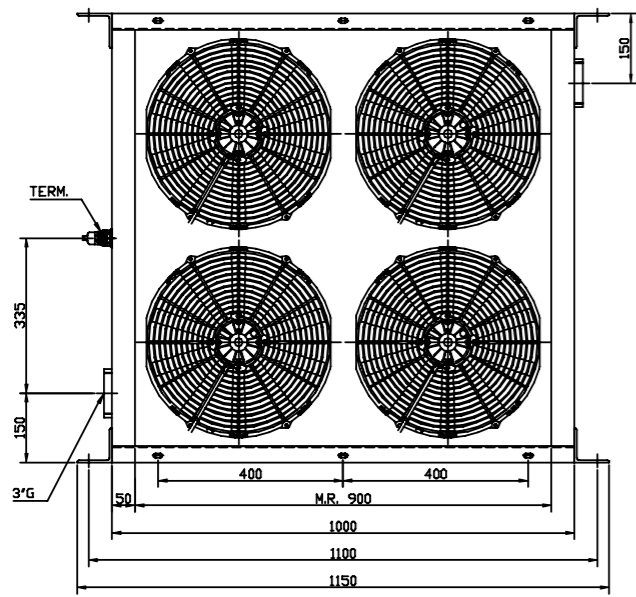

Vcc

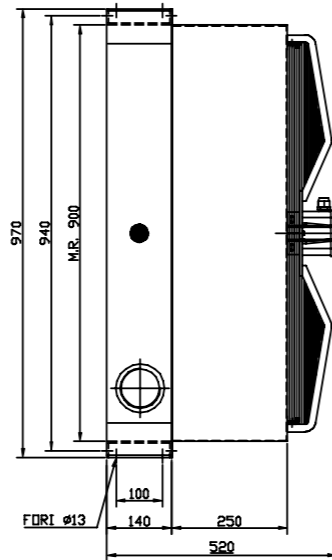
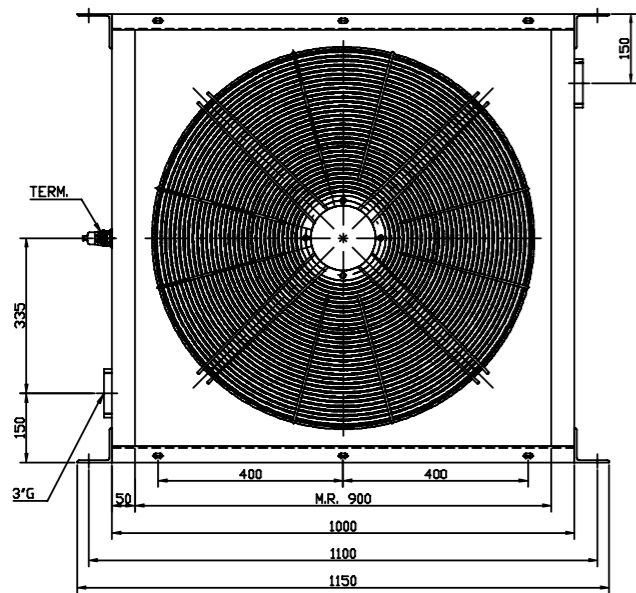

Vac

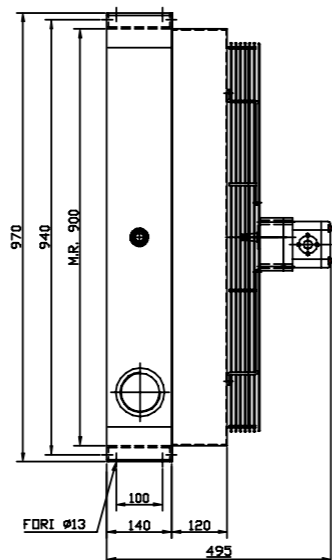
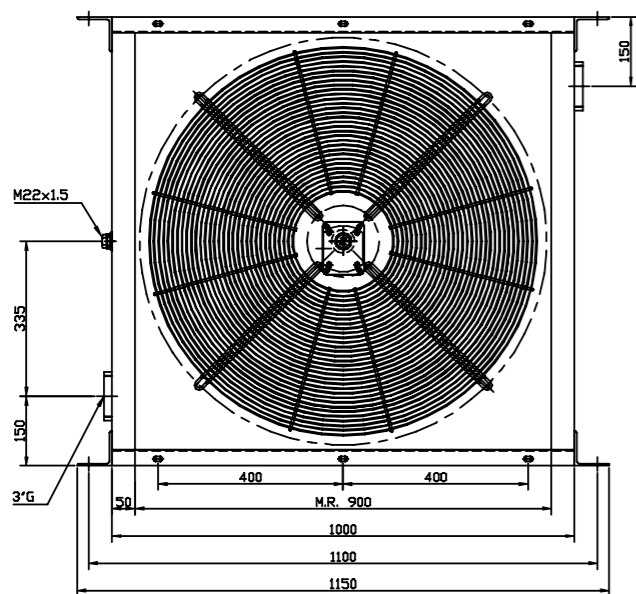

GR2

**DATI TECNICI - TECHNICAL DATA**

TENSIONE VOLTAGE	ASSORBIMENTO CURRENT	PORTATA ARIA AIR FLOW	PROTEZIONE PROTECTION	Ø
V	A	m <sup>3</sup> /h	IP	mm
12	18,1 x 4	3220 x 4	68	385 x 4
24	8 x 4	3080 x 4	68	385 x 4
230 Hz 50			/	800
400 Hz 50	4,30	21000	54	800
Predisposizione GR2 - Prepared for GR2			/	800

**DIAGRAMMA DI RENDIMENTO - PERFORMANCE DIAGRAM**

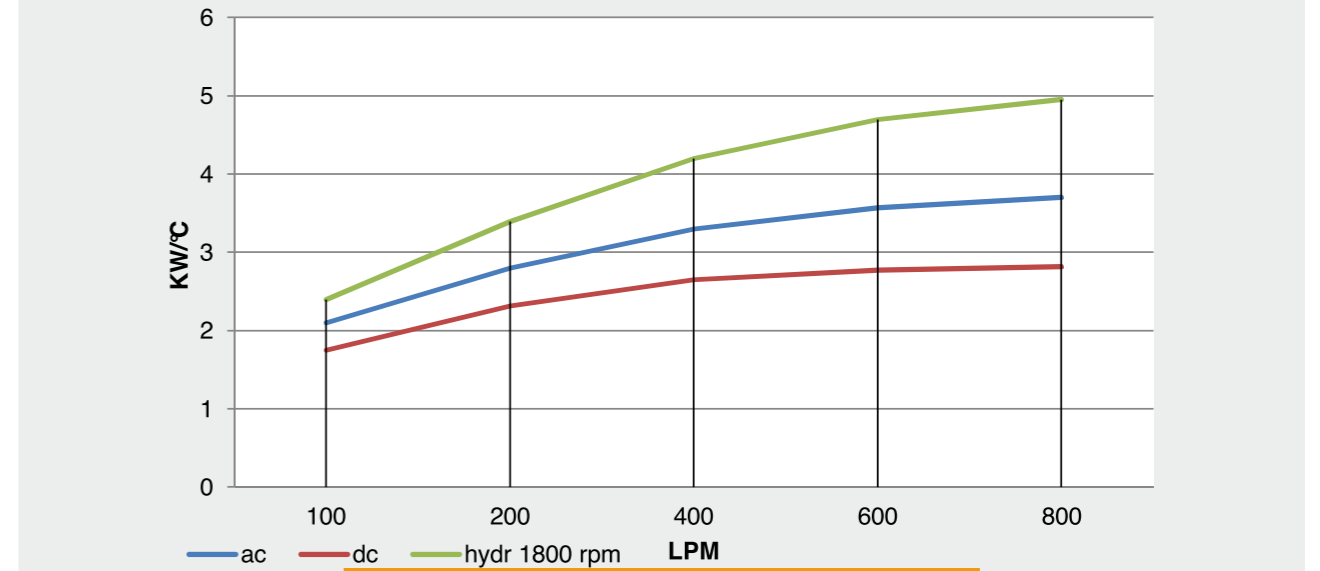

**DIAGRAMMA PERDITE DI CARICO - PRESSURE DROP DIAGRAM**

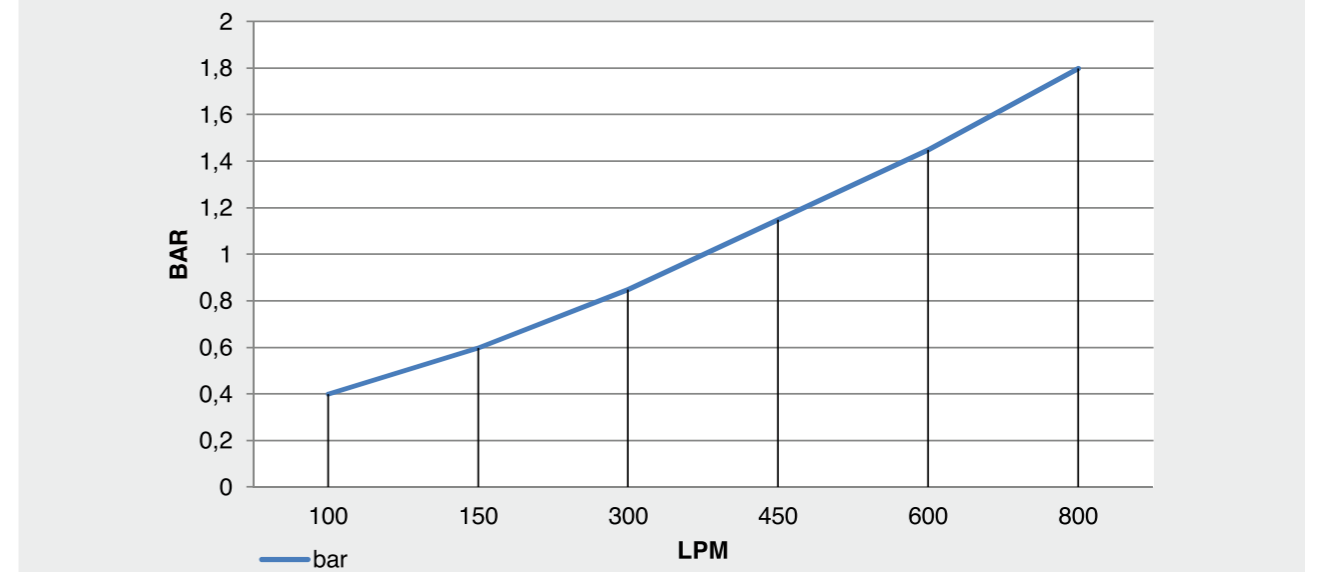

Portata olio - Oil flow: 100-880 lt/1'

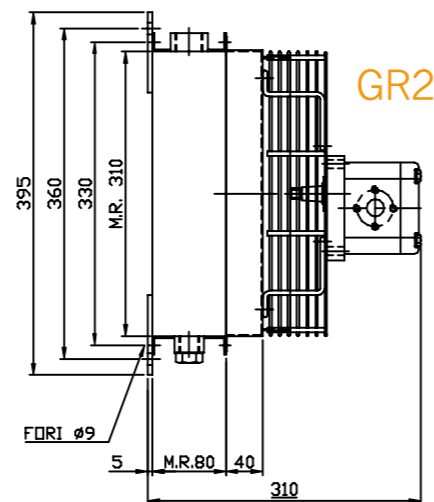
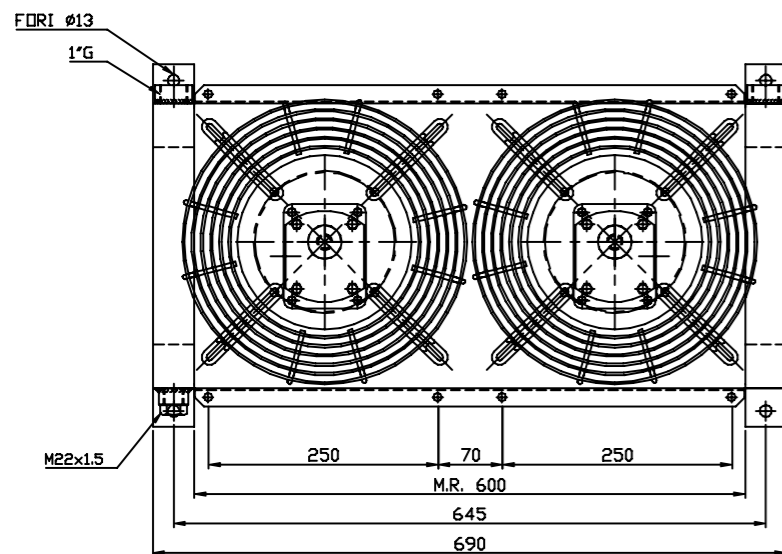
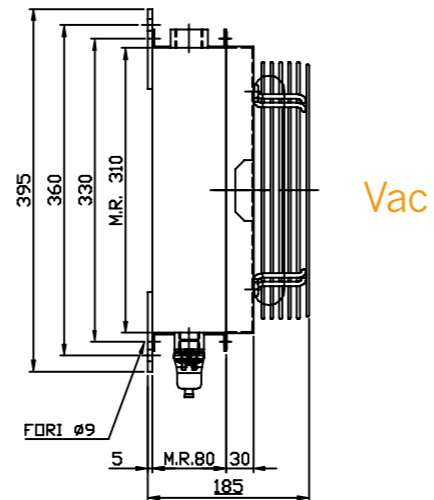
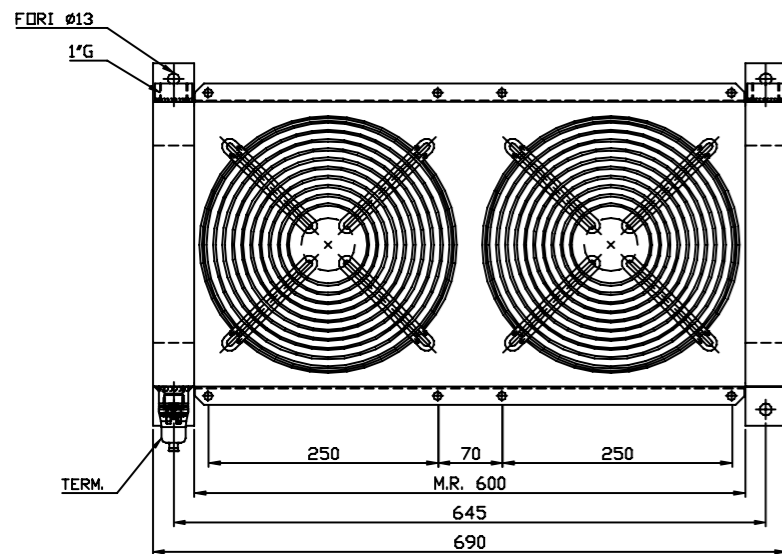
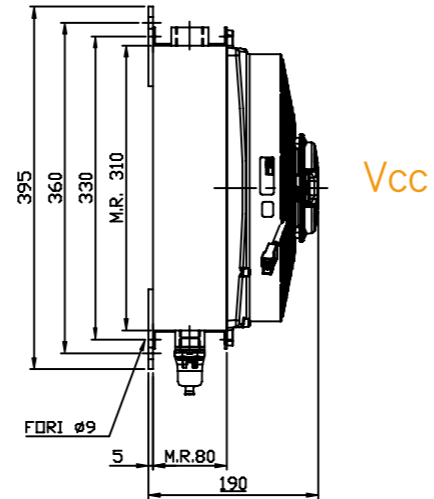
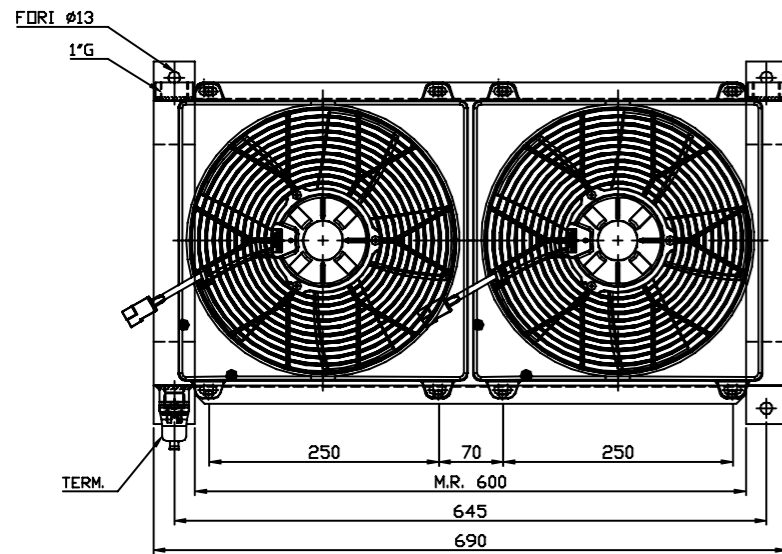

DATI TECNICI - TECHNICAL DATA

TENSIONE VOLTAGE	ASSORBIMENTO CURRENT	PORTATA ARIA AIR FLOW	PROTEZIONE PROTECTION	Ø
V	A	m <sup>3</sup> /h	IP	mm
12	7,8 x 2	1290 x 2	68	280 x 2
24	3,9 x 2	1270 x 2	68	280 x 2
230 Hz 50/60	0,51 / 0,66 x 2	1820 / 1970 x 2	44	250 x 2
230/400 Hz 50/60	0,34-0,20 / 0,40-0,23 x 2	1830 / 1950 x 2	44	250 x 2
Predisposizione GR2 - Prepared for GR2			/	280 x 2

DIAGRAMMA DI RENDIMENTO - PERFORMANCE DIAGRAM



DIAGRAMMA PERDITE DI CARICO - PRESSURE DROP DIAGRAM



Portata olio - Oil flow: 40-180 lt/1'

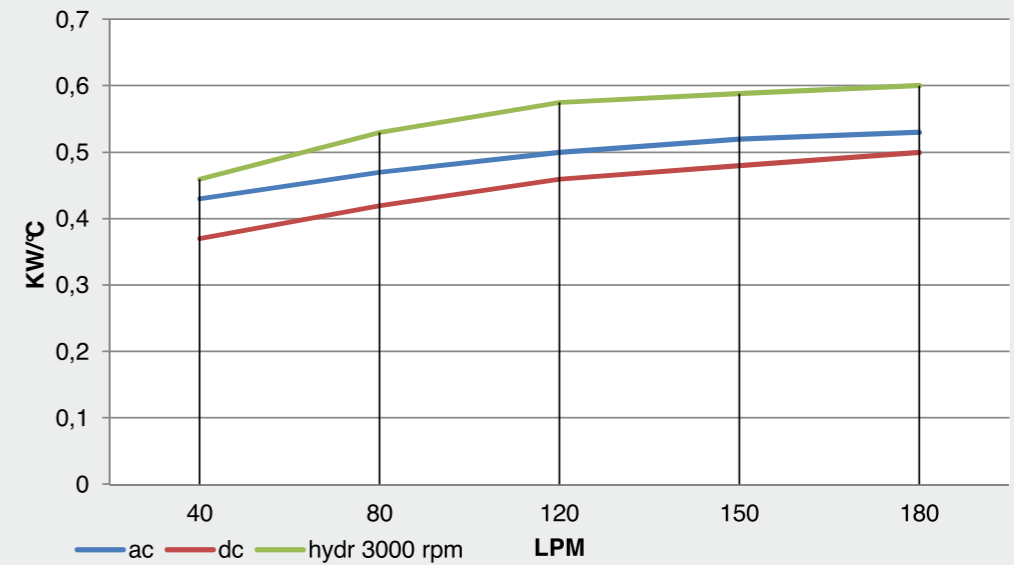
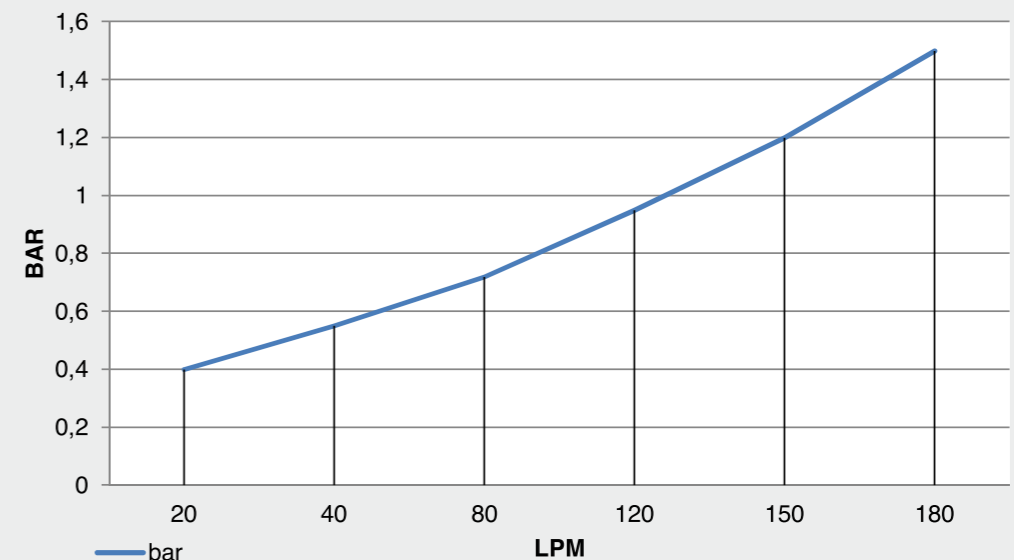
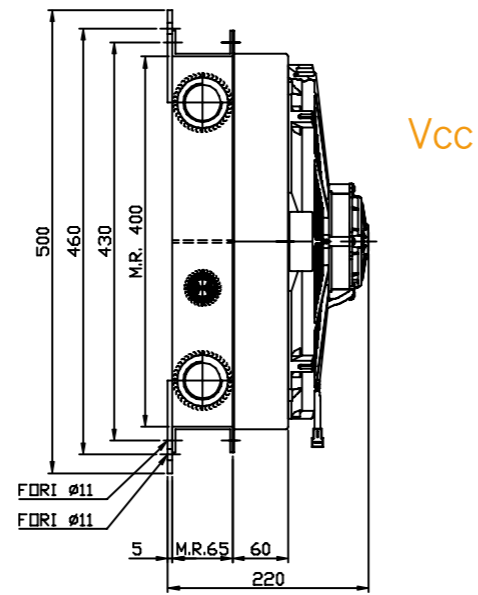
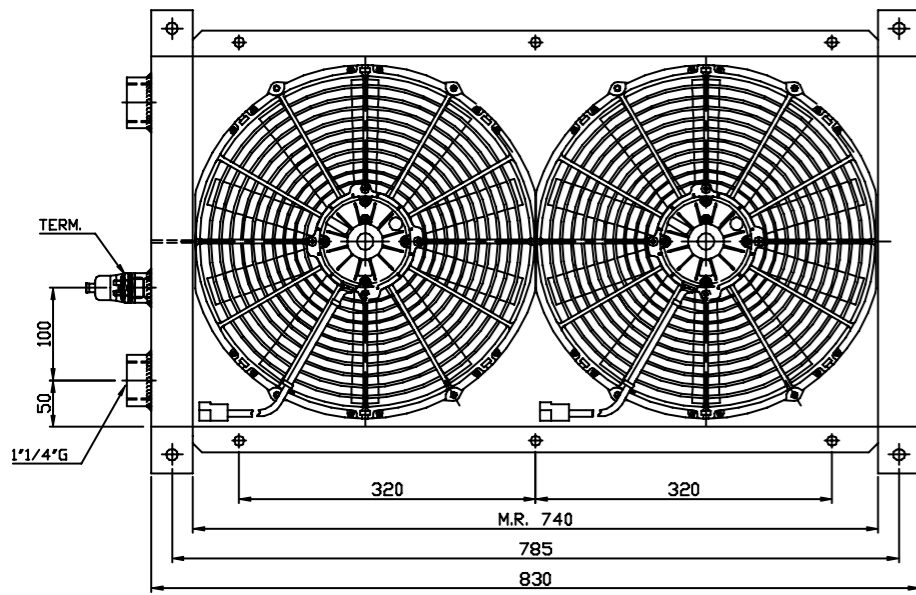

Vcc

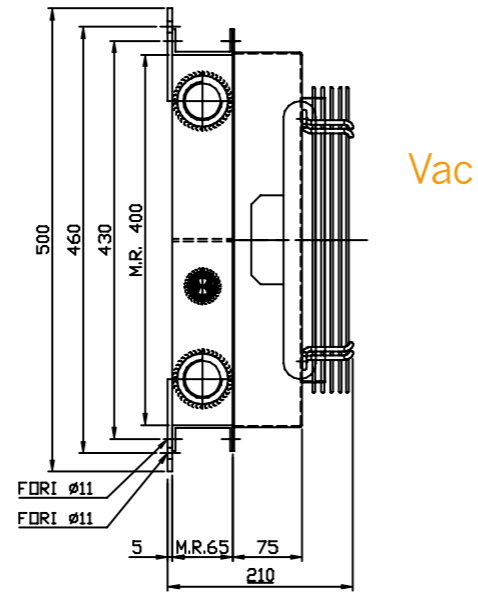
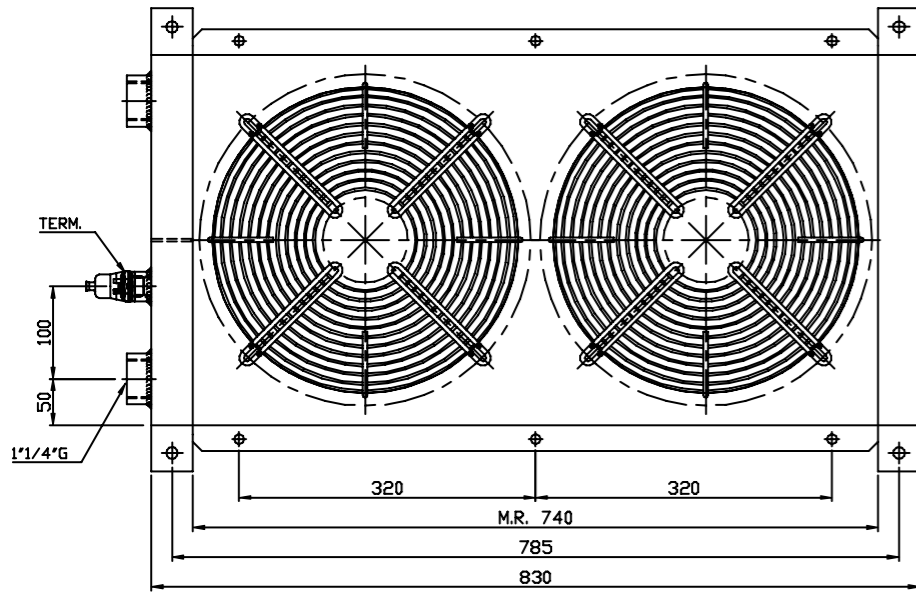

Vac

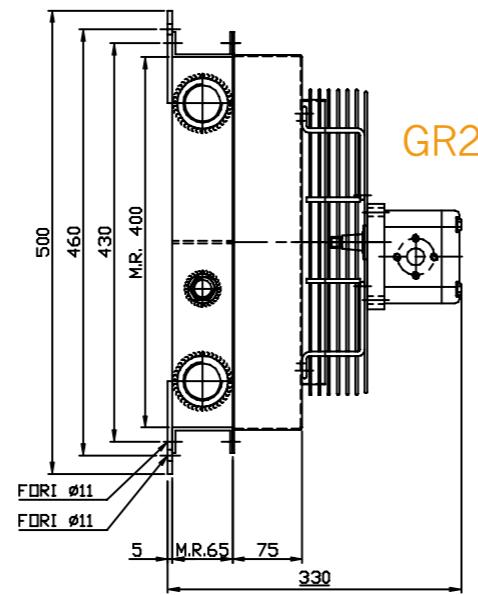
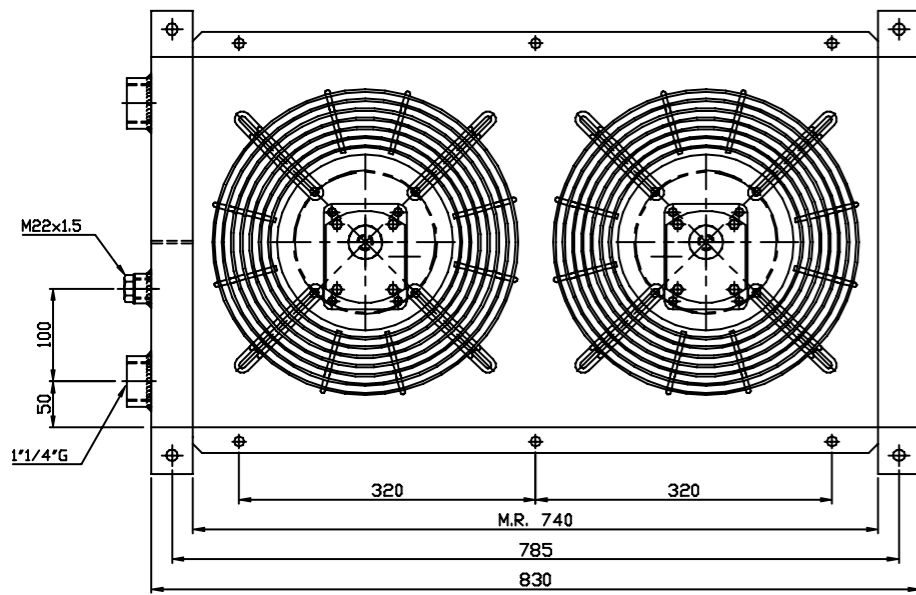

GR2

**DATI TECNICI - TECHNICAL DATA**

TENSIONE VOLTAGE	ASSORBIMENTO CURRENT	PORTATA ARIA AIR FLOW	PROTEZIONE PROTECTION	Ø
V	A	m <sup>3</sup> /h	IP	mm
12	18,7 x 2	2840 x 2	68	350
24	10,1 x 2	2810 x 2	68	350
230 Hz 50/60	1,1 / 1,55 x 2	3410 / 3740 x 2	44	300
230/400 Hz 50/60	0,62-0,36 / 0,83-0,48 x 2	3130 / 3350 x 2	44	300
Predisposizione GR2 - Prepared for GR2			/	300

**DIAGRAMMA DI RENDIMENTO - PERFORMANCE DIAGRAM**

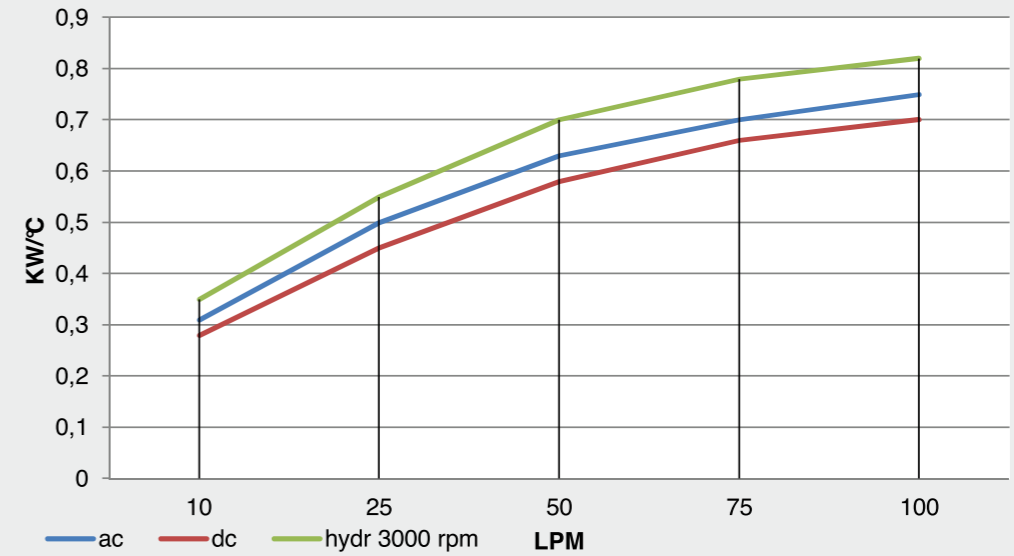

**DIAGRAMMA PERDITE DI CARICO - PRESSURE DROP DIAGRAM**

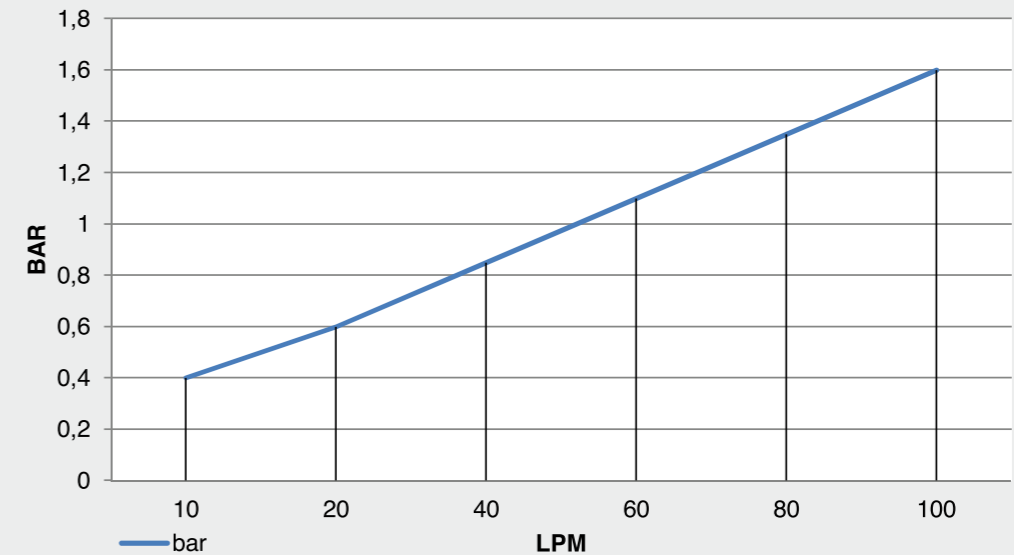

Portata olio - Oil flow: 15-100 lt/1'

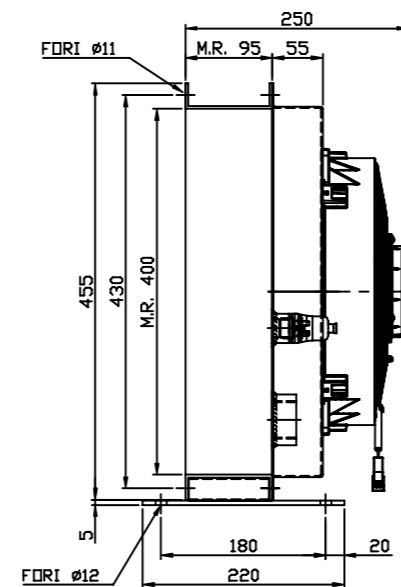
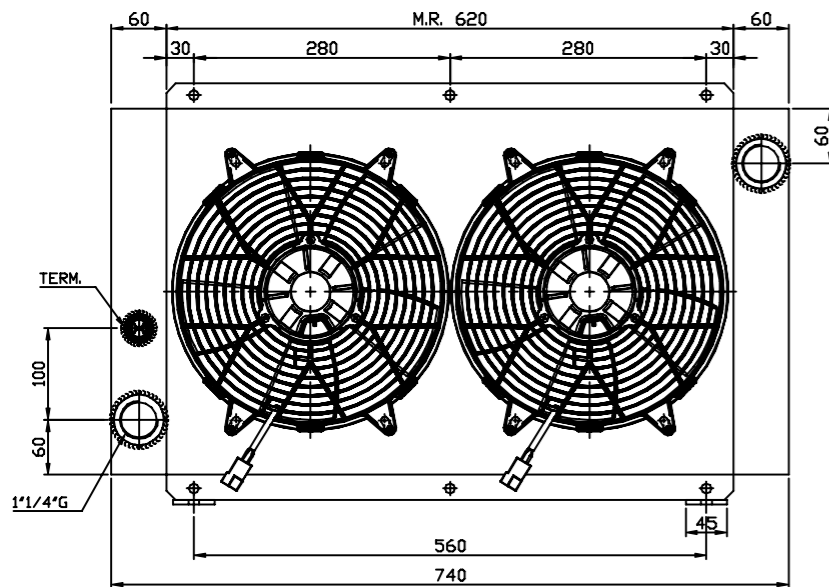

Vcc

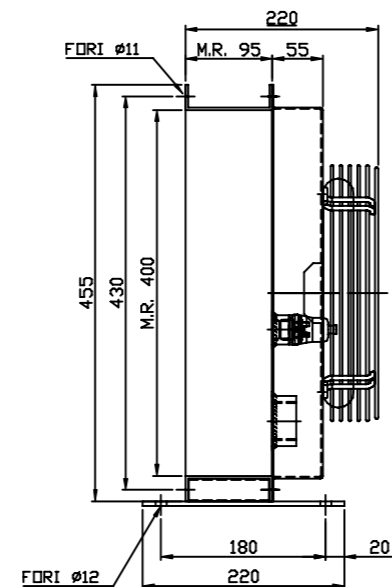
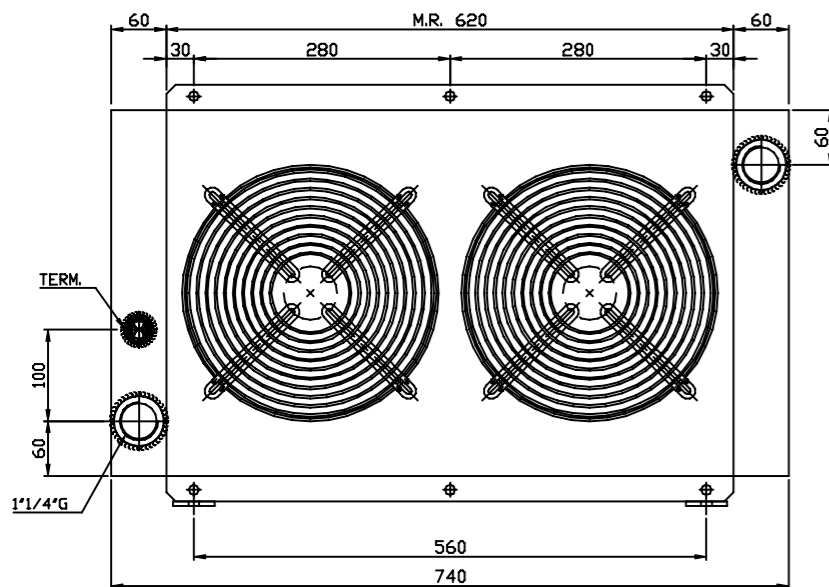

Vac

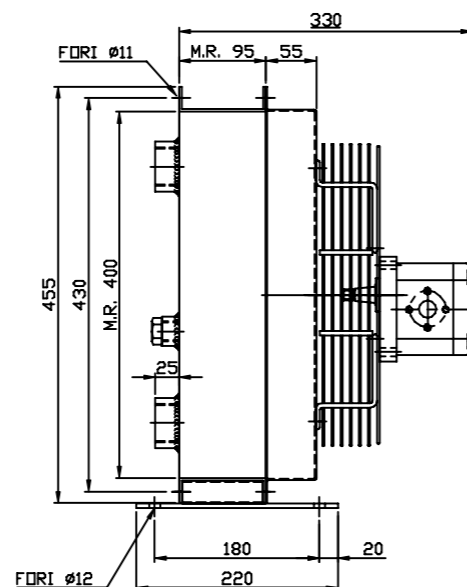
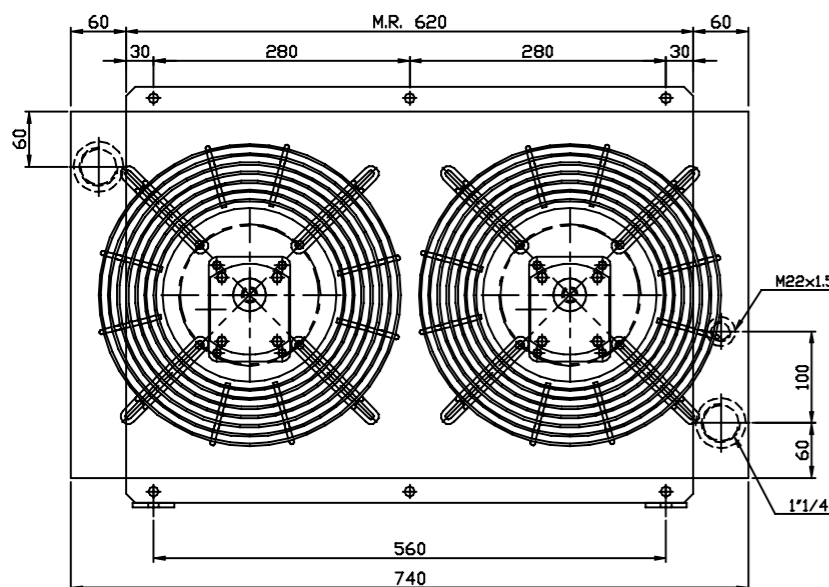

GR2

**DATI TECNICI - TECHNICAL DATA**

TENSIONE VOLTAGE	ASSORBIMENTO CURRENT	PORTATA ARIA AIR FLOW	PROTEZIONE PROTECTION	Ø
V	A	m <sup>3</sup> /h	IP	mm
12	16,6 x 2	2010 x 2	68	280 x 2
24	8 x 2	2010 x 2	68	280 x 2
230 Hz 50/60	0,051 / 0,66 x 2	1820 / 1970 x 2	44	250 x 2
230/400 Hz 50/60	0,34-0,20 / 0,40-0,23 x 2	1830 / 1950 x 2	44	250 x 2
Predisposizione GR2 - Prepared for GR2				300 x 2

**DIAGRAMMA DI RENDIMENTO - PERFORMANCE DIAGRAM**

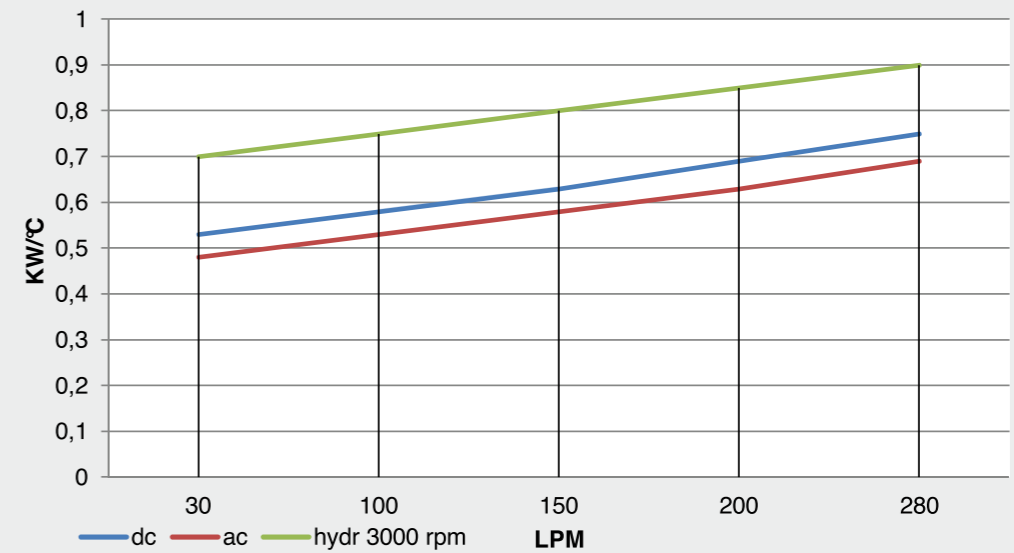

**DIAGRAMMA PERDITE DI CARICO - PRESSURE DROP DIAGRAM**

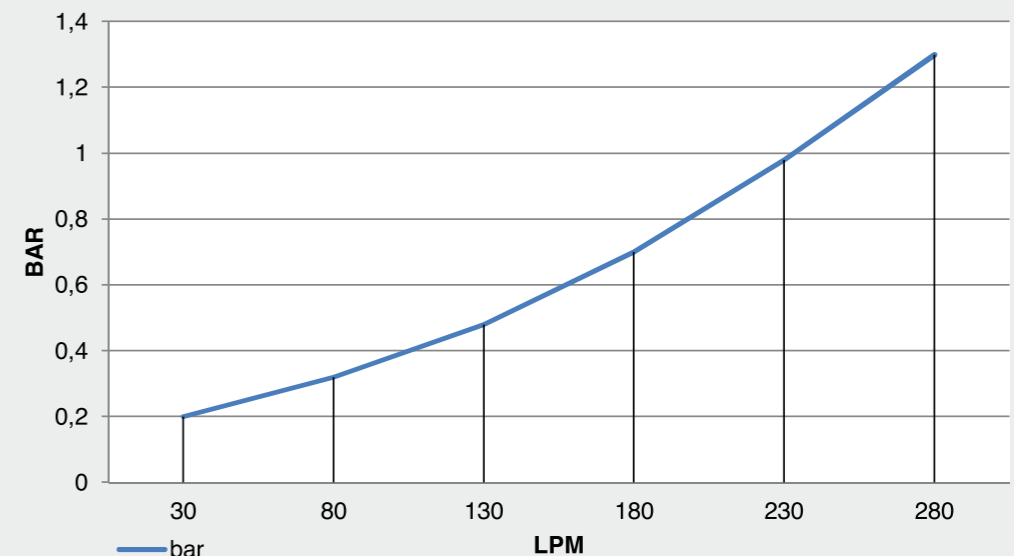

Portata olio - Oil flow: 30-280 lt/1'

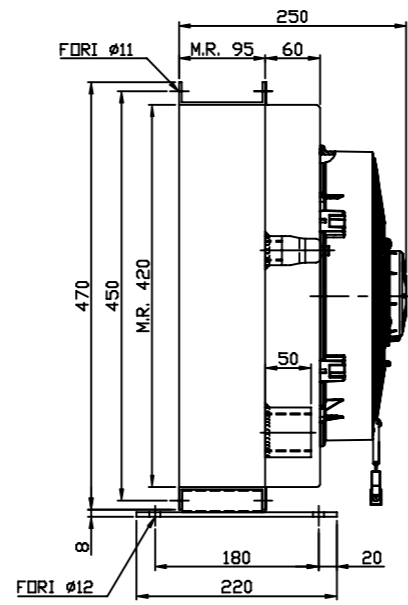
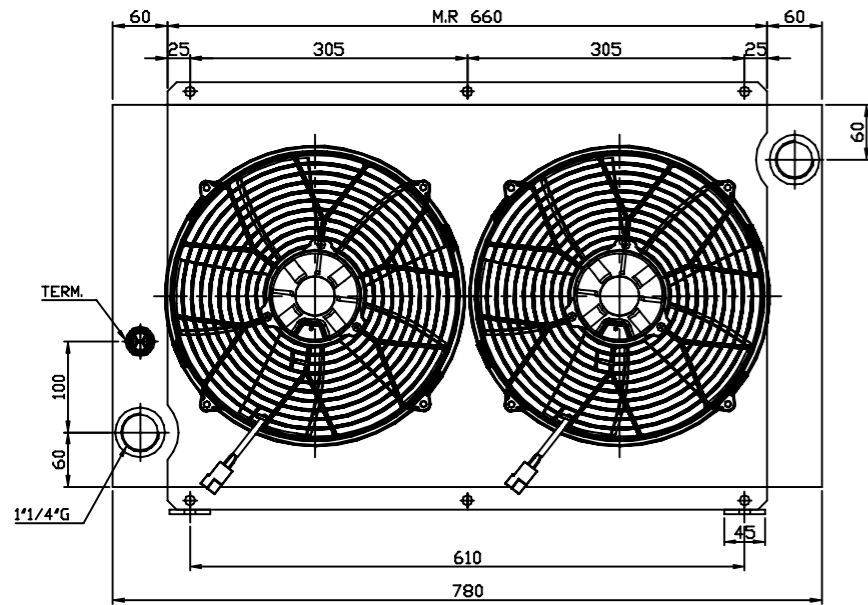

Vcc

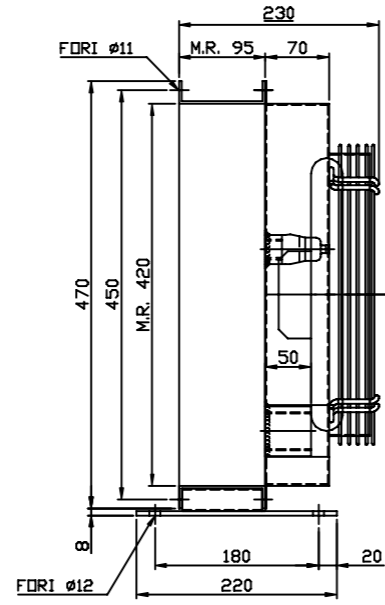
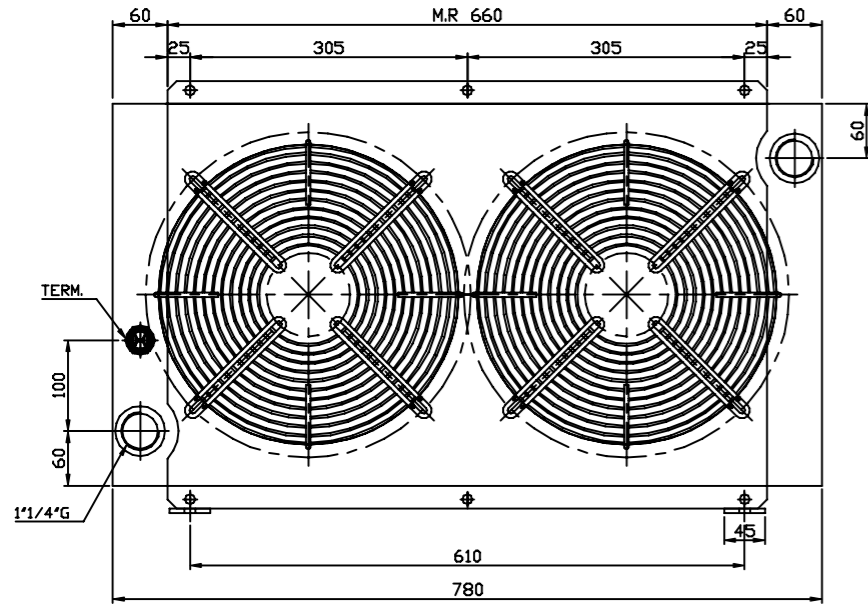

Vac

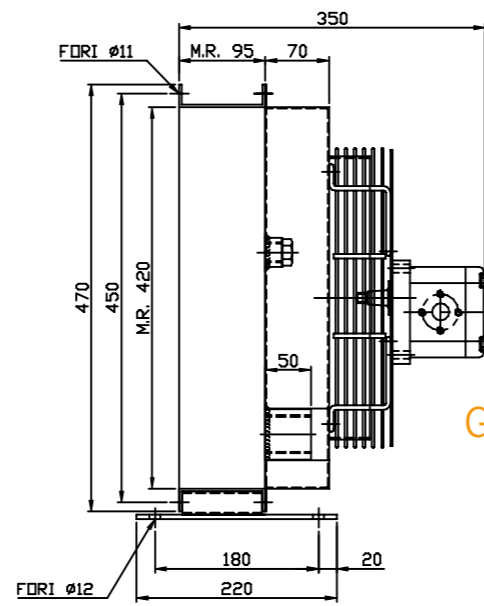
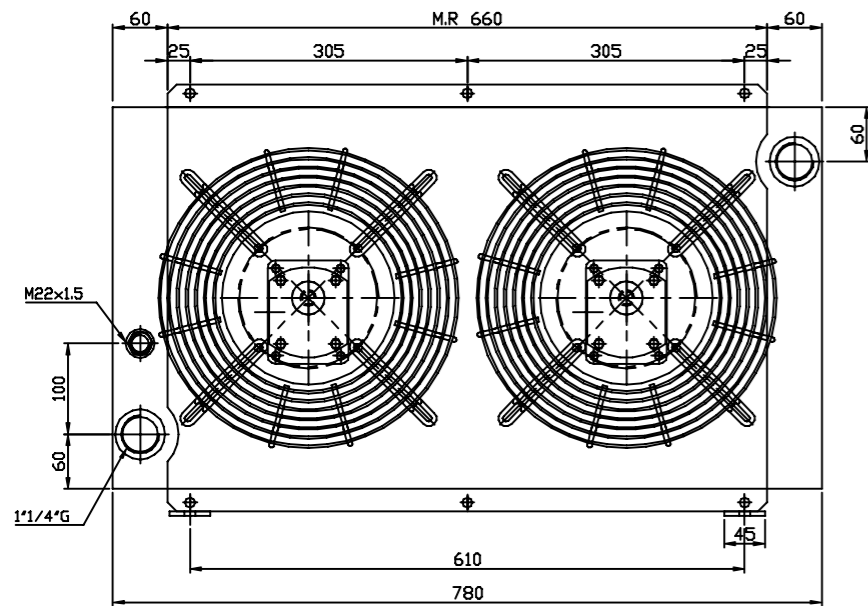

GR2

**DATI TECNICI - TECHNICAL DATA**

TENSIONE VOLTAGE	ASSORBIMENTO CURRENT	PORTATA ARIA AIR FLOW	PROTEZIONE PROTECTION	Ø
V	A	m <sup>3</sup> /h	IP	mm
12	20,7 x 2	2490 x 2	68	305
24	10 x 2	2520 x 2	68	305
230 Hz 50/60	1,1 / 1,55 x 2	3410 / 3740 x 2	44	300
230/400 Hz 50/60	0,62-0,36 / 0,83-0,48 x 2	3130 / 3350 x 2	44	300
Predisposizione GR2 - Prepared for GR2			/	300

**DIAGRAMMA DI RENDIMENTO - PERFORMANCE DIAGRAM**

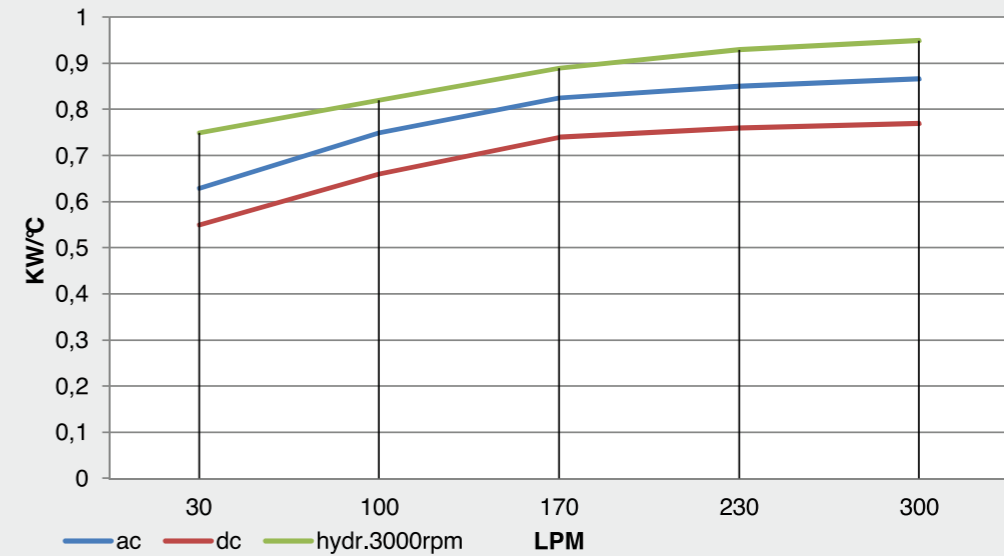

**DIAGRAMMA PERDITE DI CARICO - PRESSURE DROP DIAGRAM**

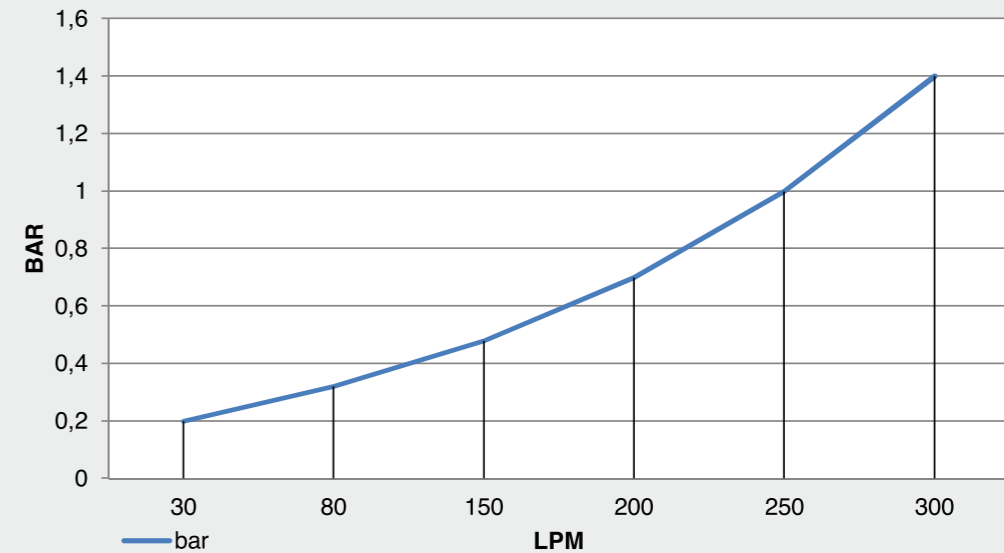

Portata olio - Oil flow: 30-300 lt/1'

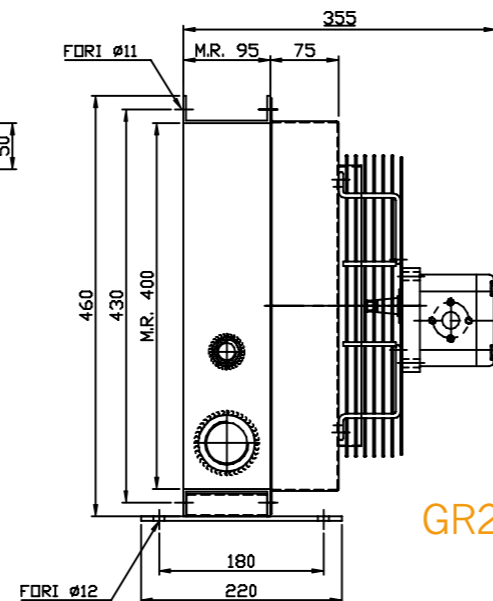
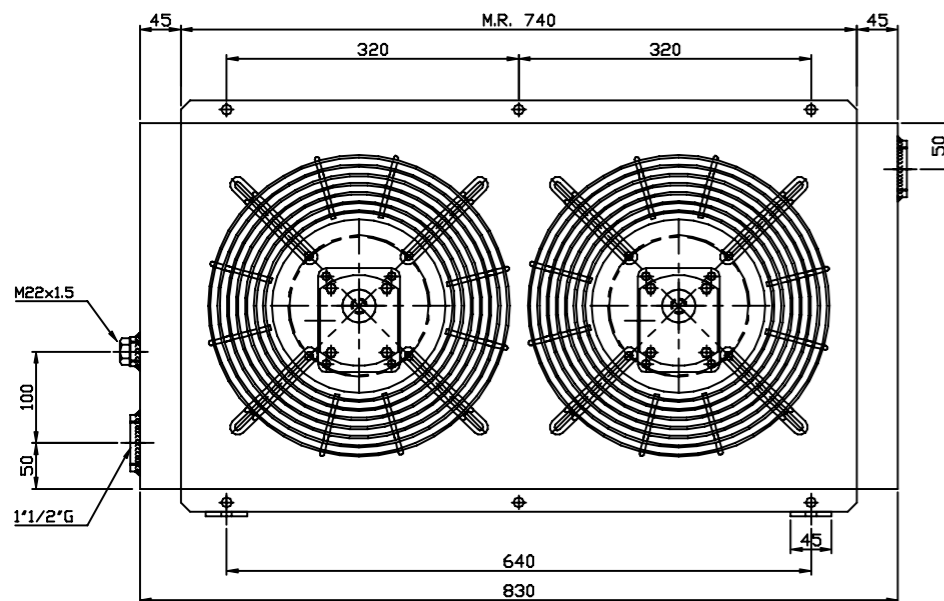
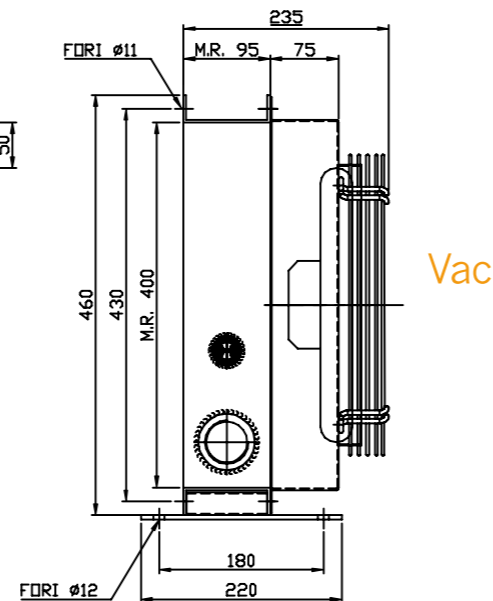
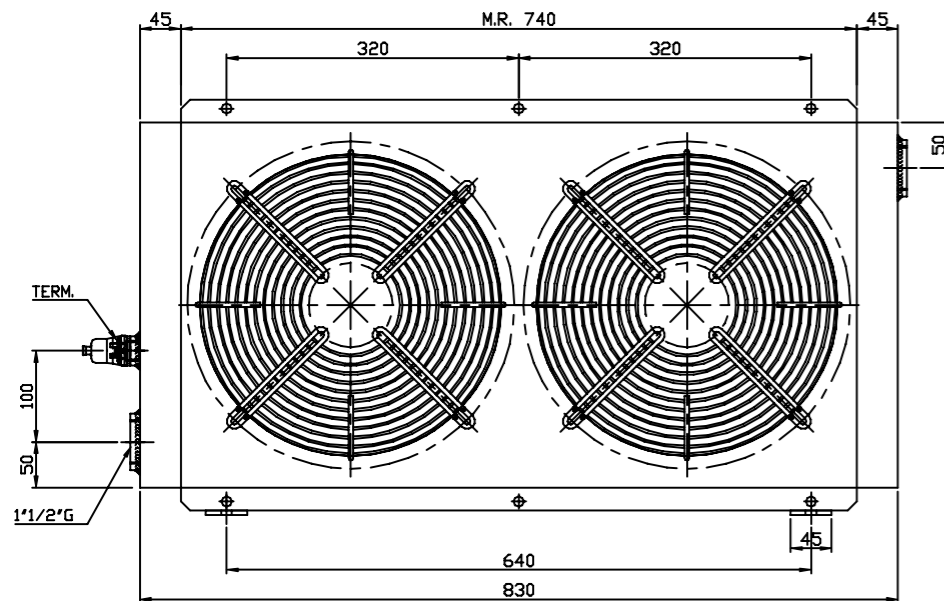
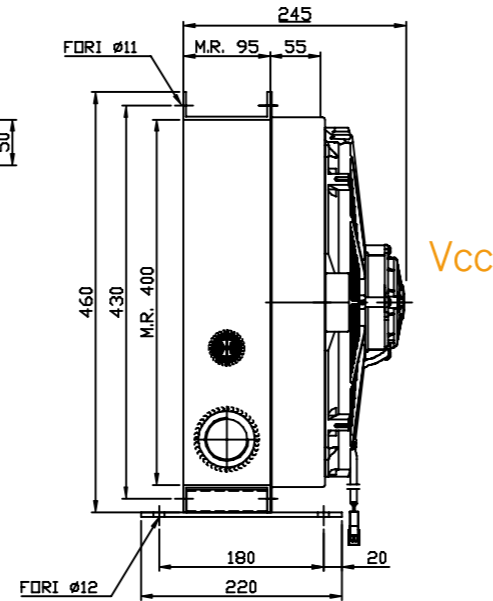
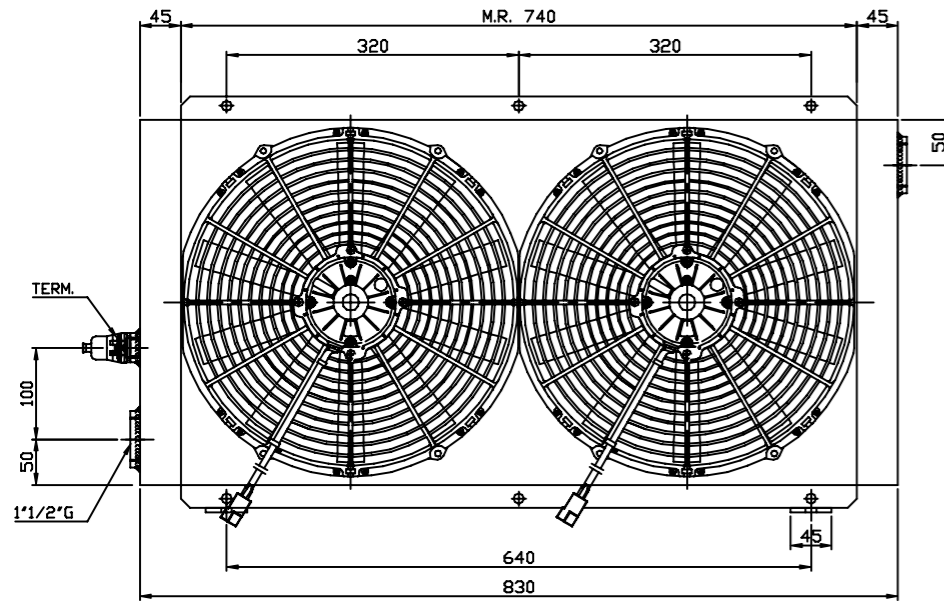

**DATI TECNICI - TECHNICAL DATA**

TENSIONE VOLTAGE	ASSORBIMENTO CURRENT	PORTATA ARIA AIR FLOW	PROTEZIONE PROTECTION	Ø
V	A	m <sup>3</sup> /h	IP	mm
12	18,7 x 2	2840 x 2	68	350
24	10,1 x 2	2810 x 2	68	350
230 Hz 50/60	1,1 / 1,55 x 2	3410 / 3740 x 2	44	300
230/400 Hz 50/60	0,62-0,36 / 0,83-0,48 x 2	3130 / 3350 x 2	44	300
Predisposizione GR2 - Prepared for GR2			/	300

**DIAGRAMMA DI RENDIMENTO - PERFORMANCE DIAGRAM**

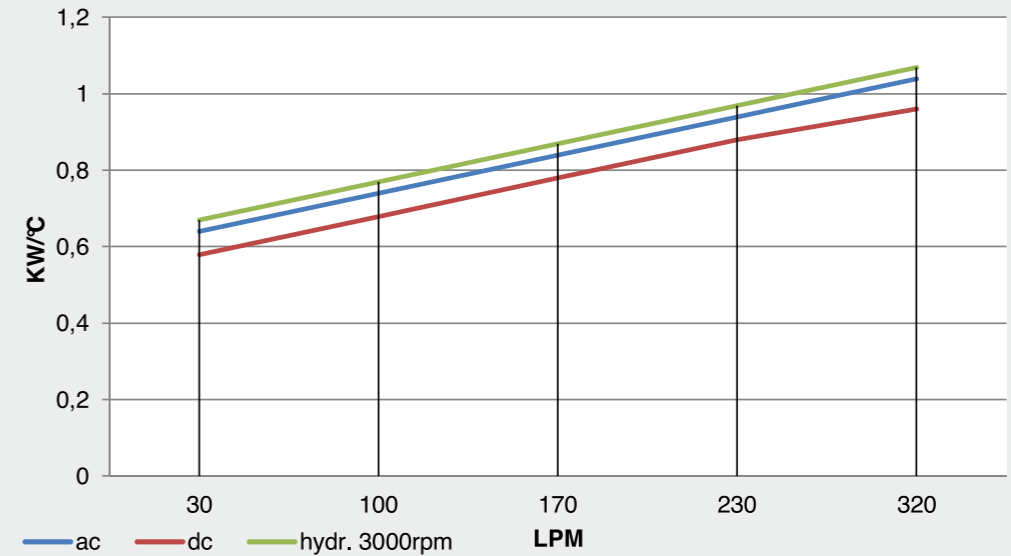

**DIAGRAMMA PERDITE DI CARICO - PRESSURE DROP DIAGRAM**

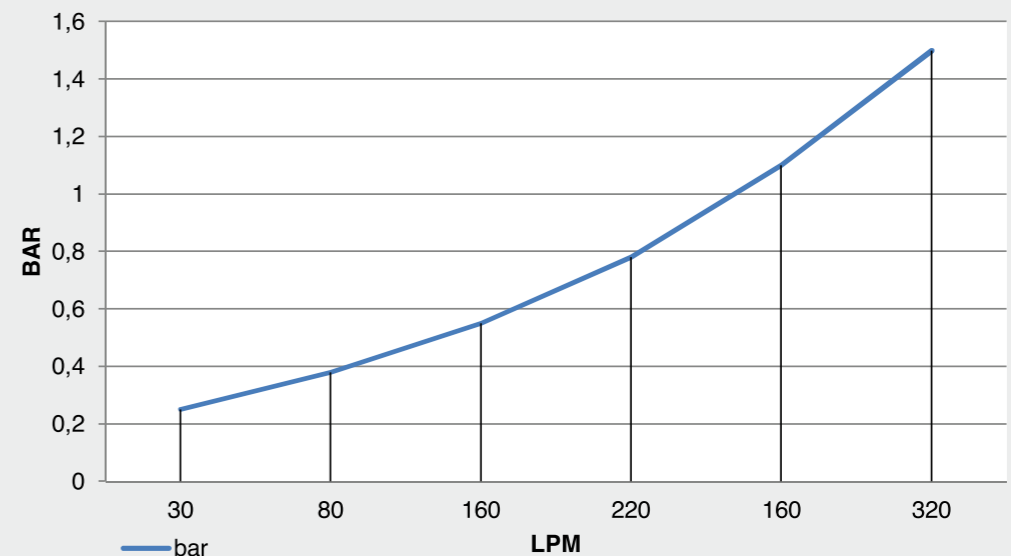

Portata olio - Oil flow: 30-320 lt/1'

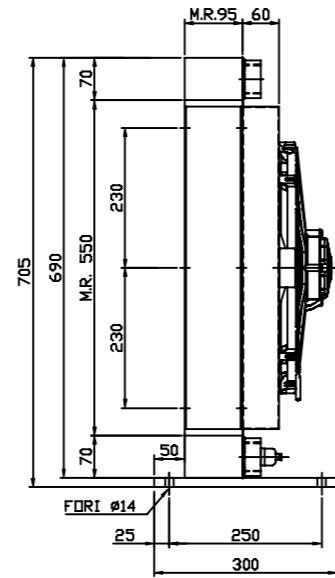
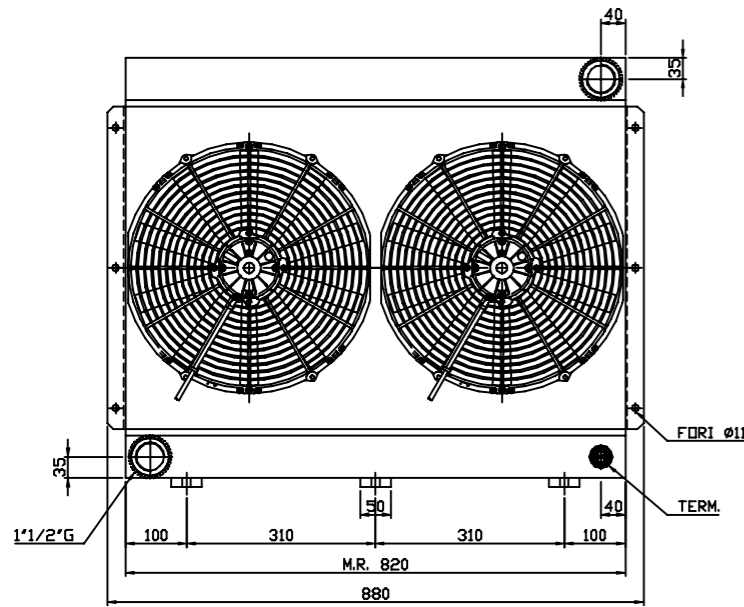

Vcc

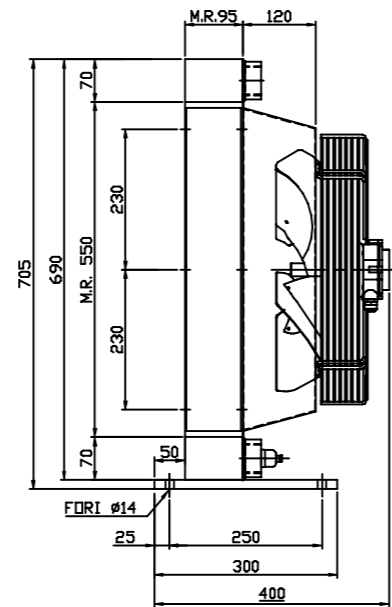
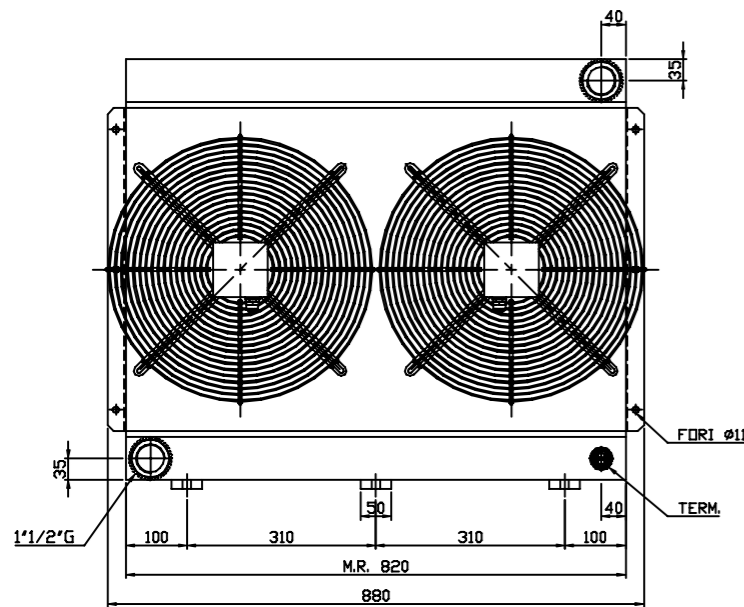

Vac

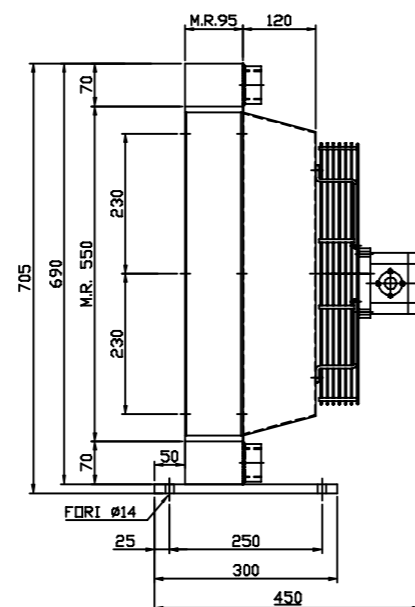
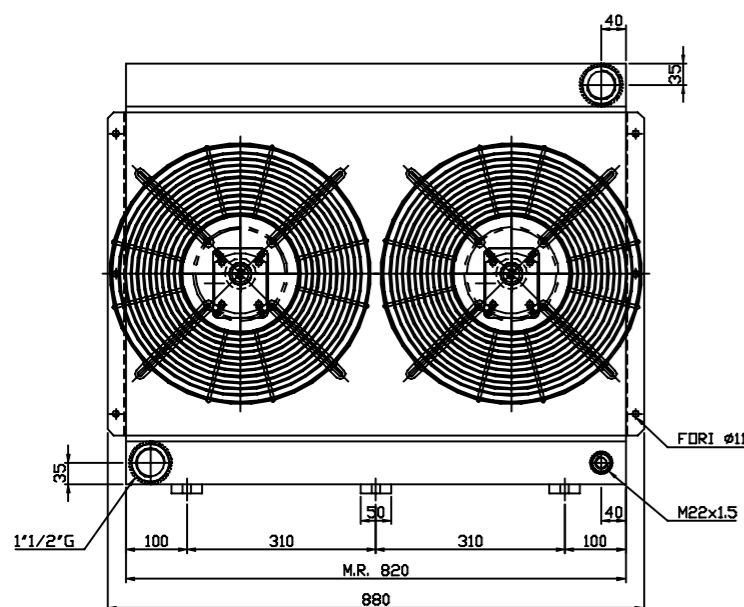

GR2

**DATI TECNICI - TECHNICAL DATA**

TENSIONE VOLTAGE	ASSORBIMENTO CURRENT	PORTATA ARIA AIR FLOW	PROTEZIONE PROTECTION	Ø
V	A	m <sup>3</sup> /h	IP	mm
12	18,1 x 2	3220 x 2	68	385
24	8 x 2	3080 x 2	68	385
230 Hz 50/60	0,73 / 1,6 x 2	4235 / 4950 x 2	44	400
230/400 Hz 50/60	0,76-0,44 / 0,68-0,39 x 2	4000 / 4610 x 2	44	400
230/400 B14 Hz 50/60 KW 0,55 rpm 1450	1,35	4860 x 2	55	400
Predisposizione GR2 - Prepared for GR2				400

**DIAGRAMMA DI RENDIMENTO - PERFORMANCE DIAGRAM**

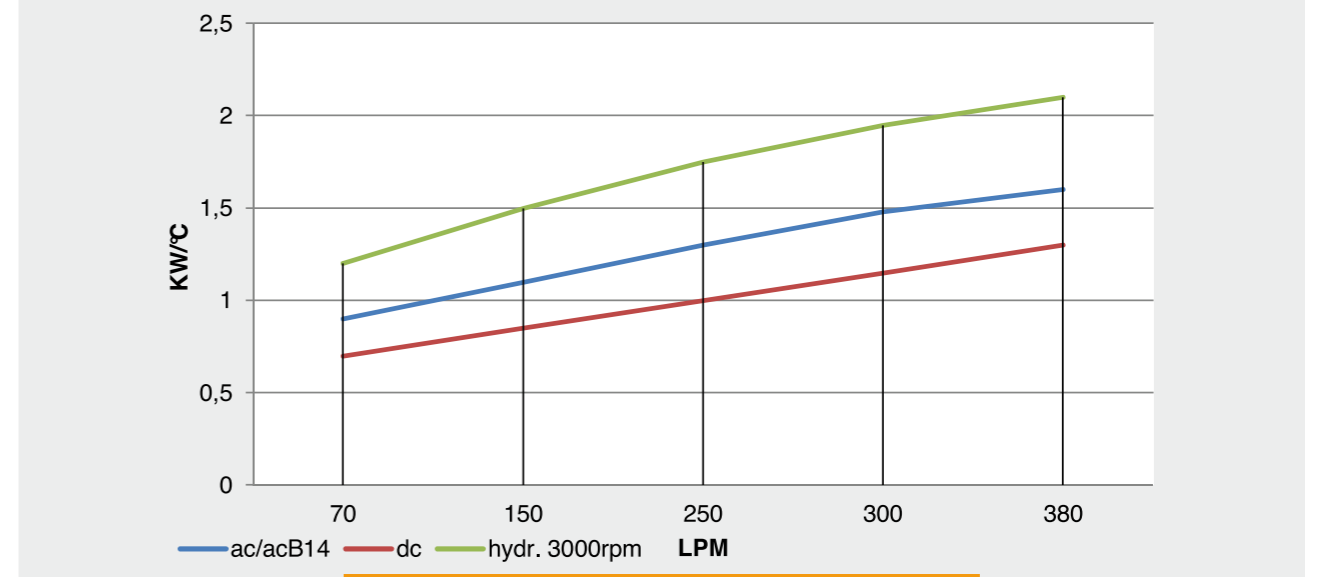

**DIAGRAMMA PERDITE DI CARICO - PRESSURE DROP DIAGRAM**

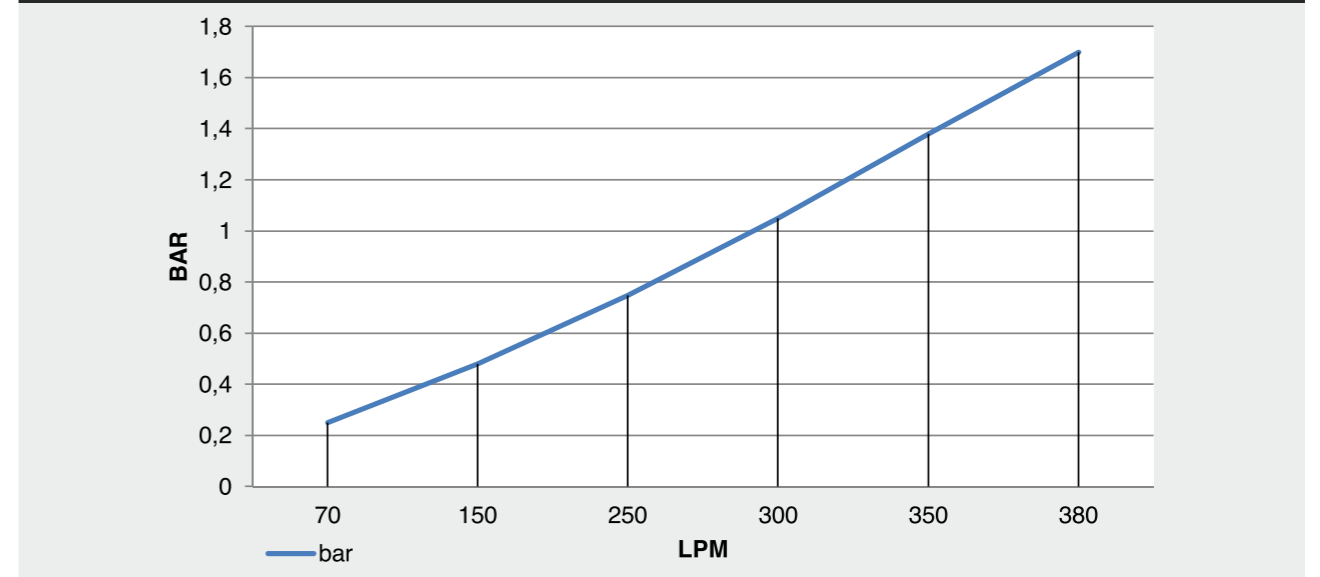

Portata olio - Oil flow: 70-380 lt/1'



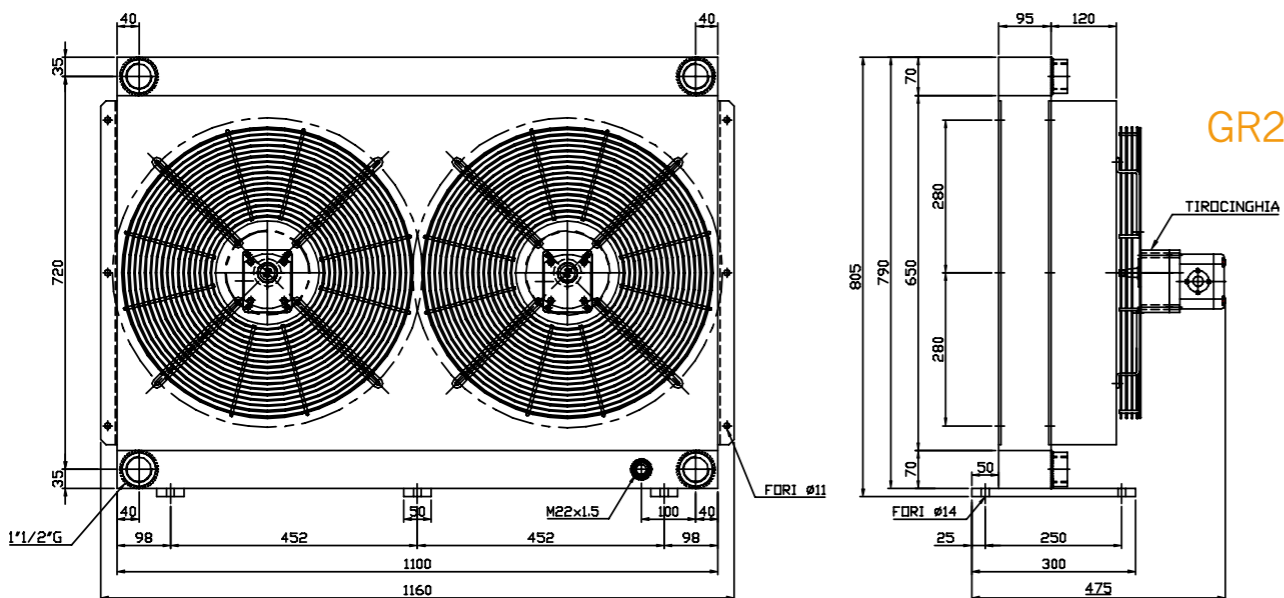
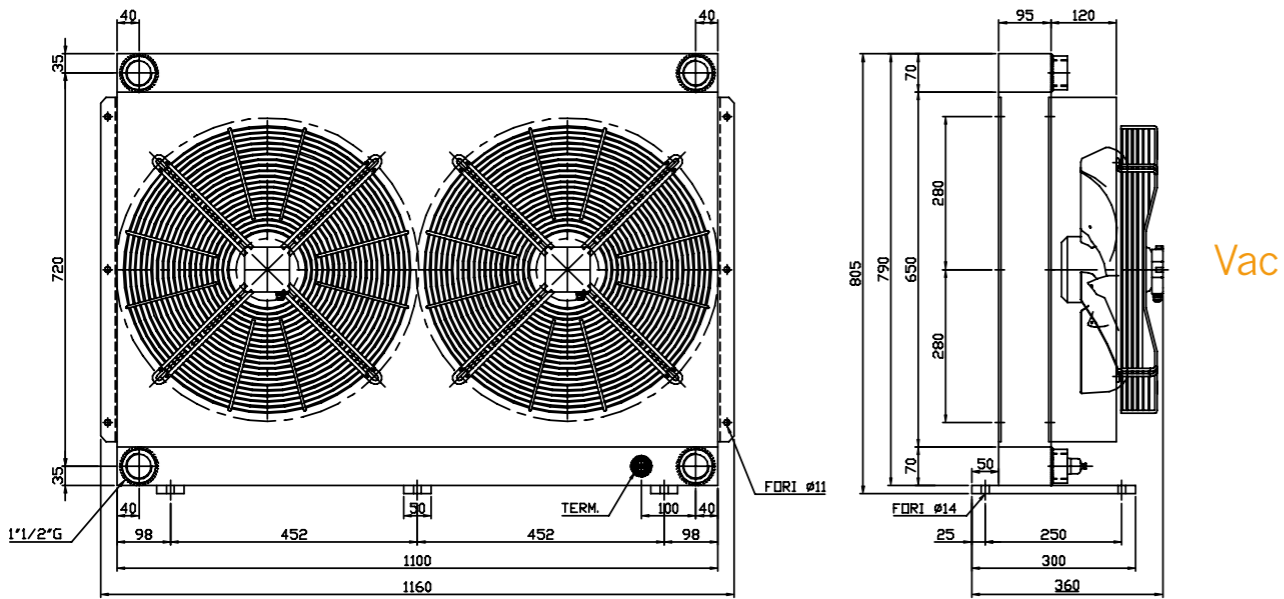
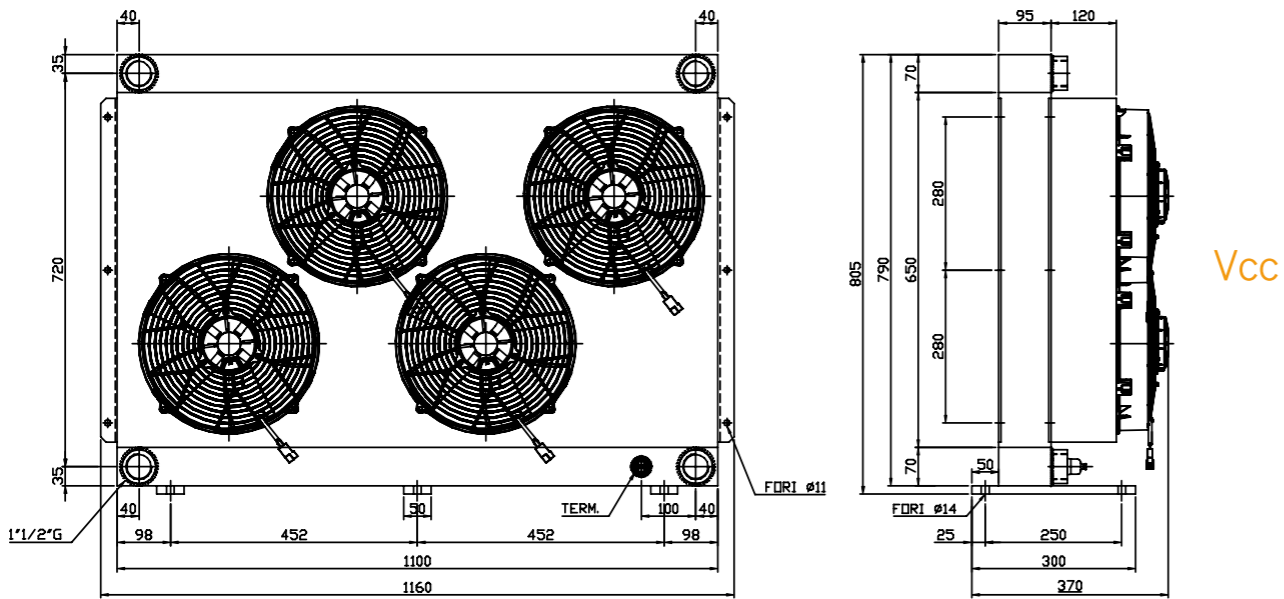

**DATI TECNICI - TECHNICAL DATA**

TENSIONE VOLTAGE	ASSORBIMENTO CURRENT	PORTATA ARIA AIR FLOW	PROTEZIONE PROTECTION	Ø
V	A	m <sup>3</sup> /h	IP	mm
12	20,7 x 4	2490 x 4	68	305
24	10 x 4	2520 x 4	68	305
230 Hz 50/60	2,36 / 2,96 x 2	6300 x 2	54	450
230/400 Hz 50/60	0,98 / 1,20 x 2	6300 x 2	54	450
230/400 B14 Hz 50/60 KW 0,55 rpm 1450			55	450
Predisposizione GR2 - Prepared for GR2			/	500

**DIAGRAMMA DI RENDIMENTO - PERFORMANCE DIAGRAM**

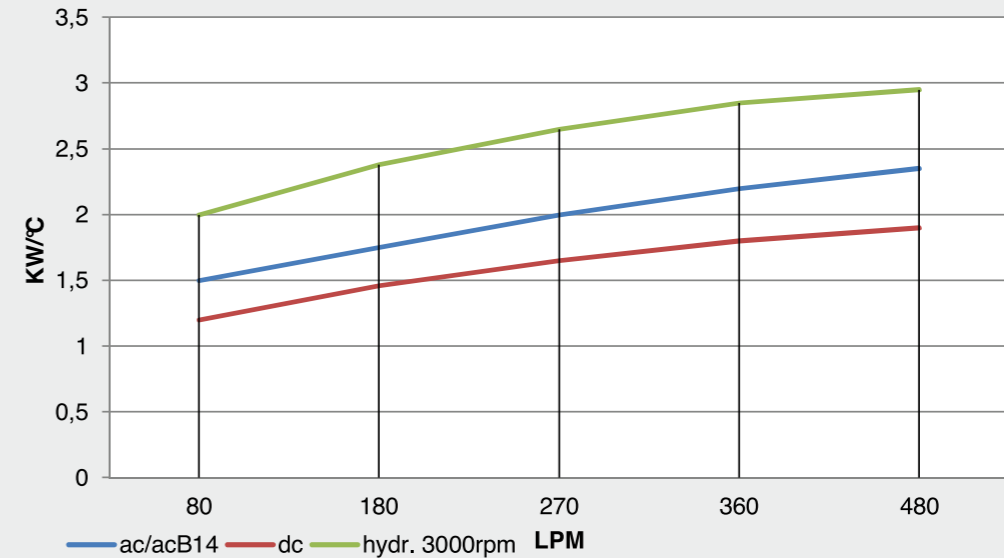

**DIAGRAMMA PERDITE DI CARICO - PRESSURE DROP DIAGRAM**

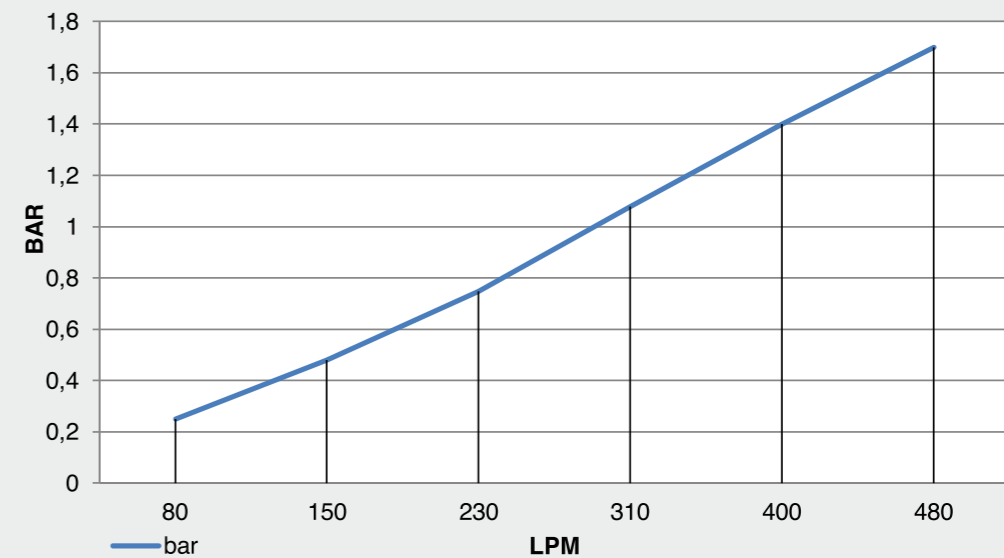

Portata olio - Oil flow: 80-480 lt/1'

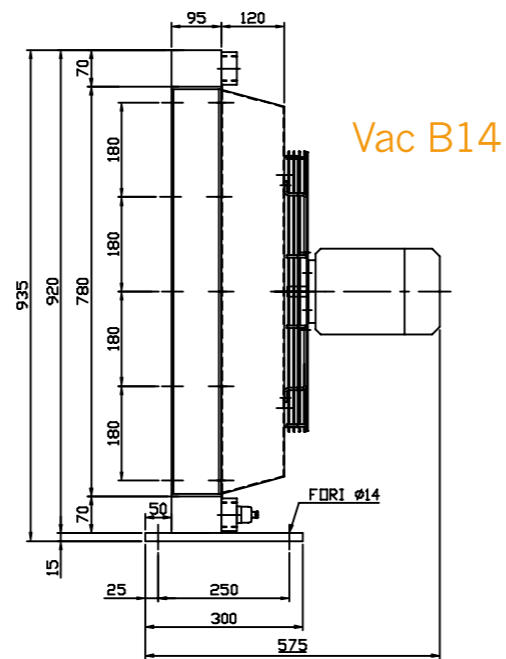
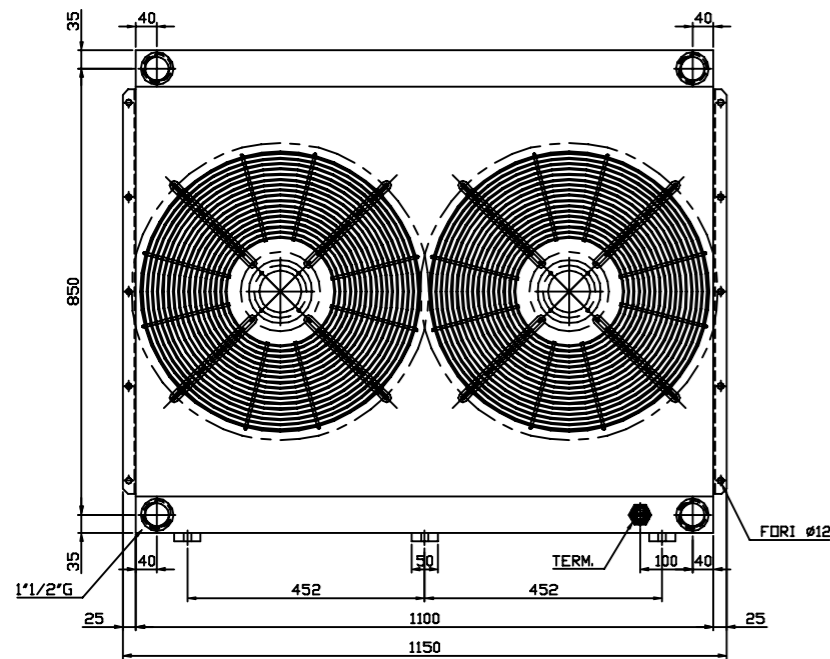

Vac B14

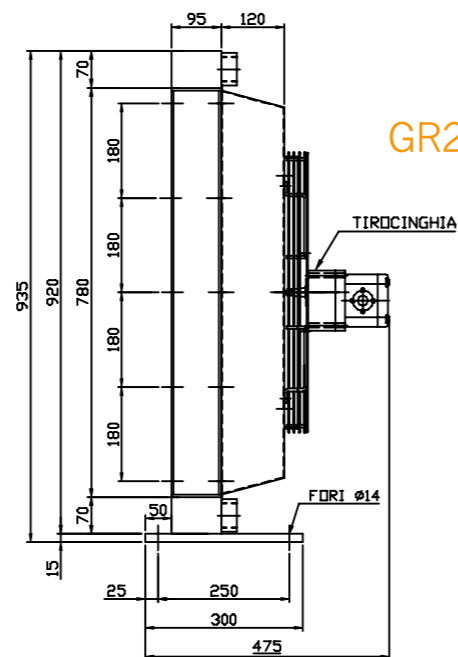
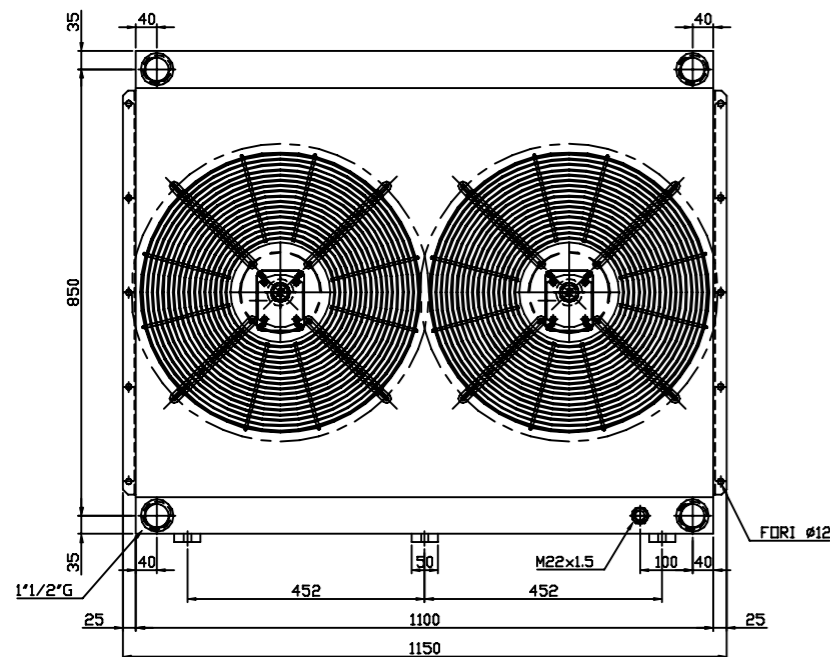

GR2

**DATI TECNICI - TECHNICAL DATA**

TENSIONE VOLTAGE	ASSORBIMENTO CURRENT	PORTATA ARIA AIR FLOW	PROTEZIONE PROTECTION	Ø
V	A	m <sup>3</sup> /h	IP	mm
230/400 B14 Hz 50/60 KW 1,1 rpm 1450	2,5	8000 x 2	55	500
Predisposizione GR2 - Prepared for GR2			/	500

**DIAGRAMMA DI RENDIMENTO - PERFORMANCE DIAGRAM**

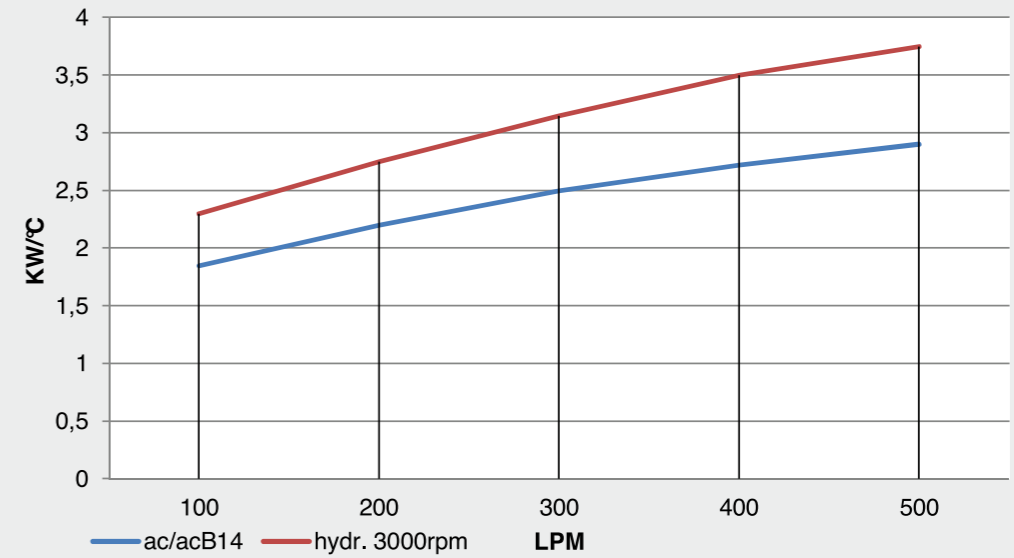

**DIAGRAMMA PERDITE DI CARICO - PRESSURE DROP DIAGRAM**

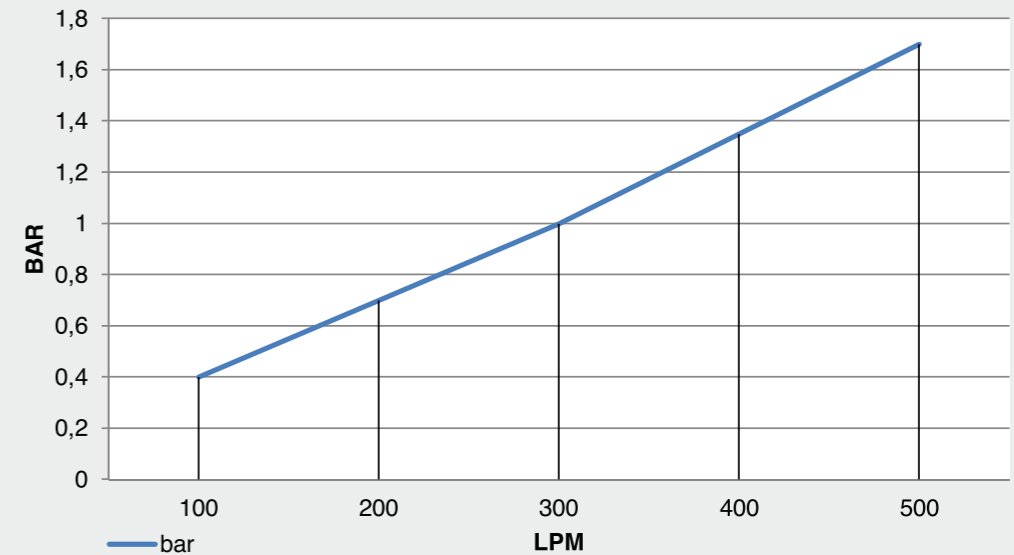

Portata olio - Oil flow: 100-500 lt/1'

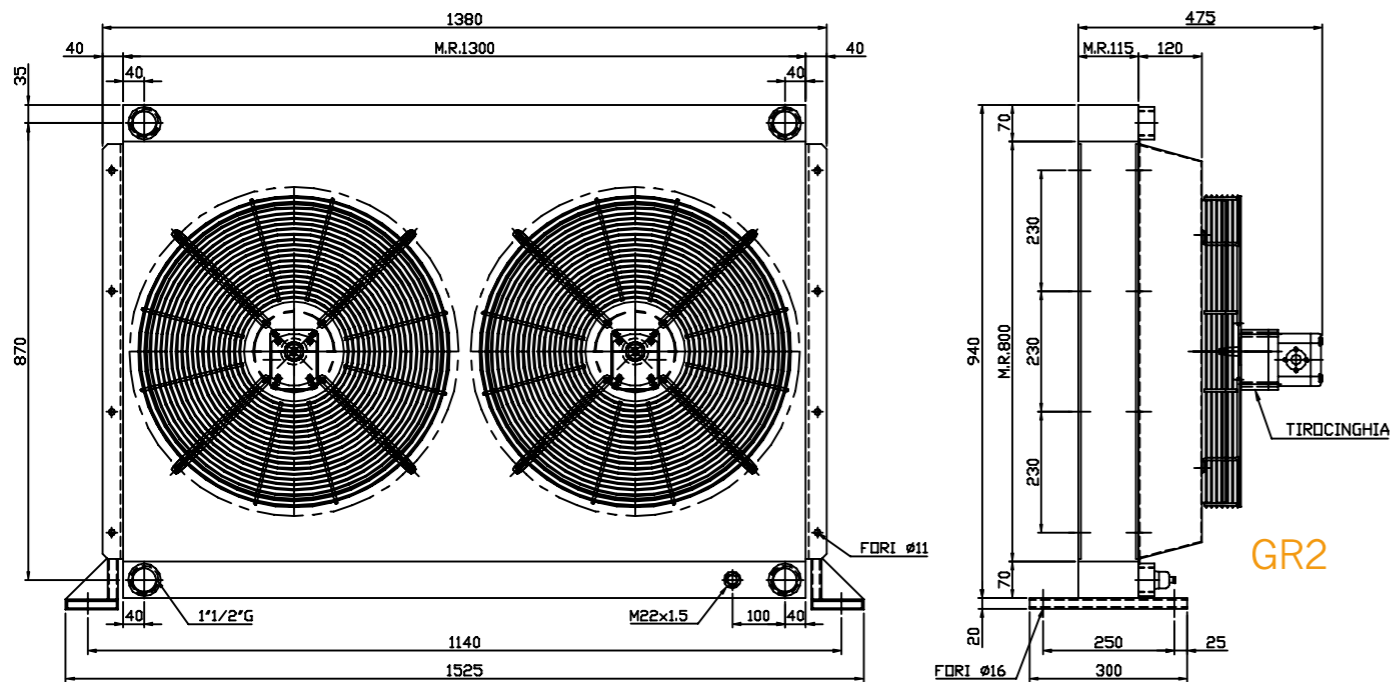
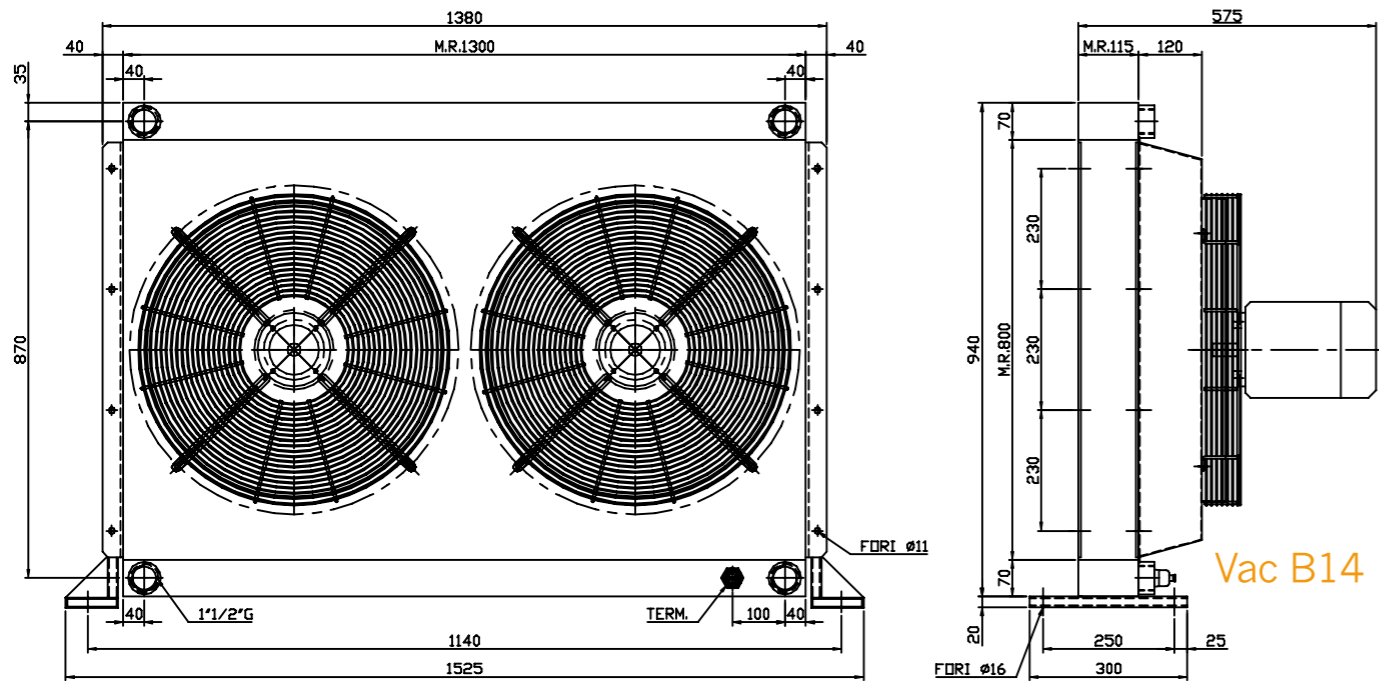

**DATI TECNICI - TECHNICAL DATA**

TENSIONE VOLTAGE	ASSORBIMENTO CURRENT	PORTATA ARIA AIR FLOW	PROTEZIONE PROTECTION	Ø
V	A	m <sup>3</sup> /h	IP	mm
230 Hz 50/60	4,15 x 2	10470 x 2	54	560
400/480 Hz 50/60	1,32 / 1,60 x 2	8910 / 10350 x 2	54	560
230/400 B14 Hz 50/60 KW 0,55 rpm 1450	2,5	8500 x 2	55	560
Predisposizione GR2 - Prepared for GR2			/	560

**DIAGRAMMA DI RENDIMENTO - PERFORMANCE DIAGRAM**

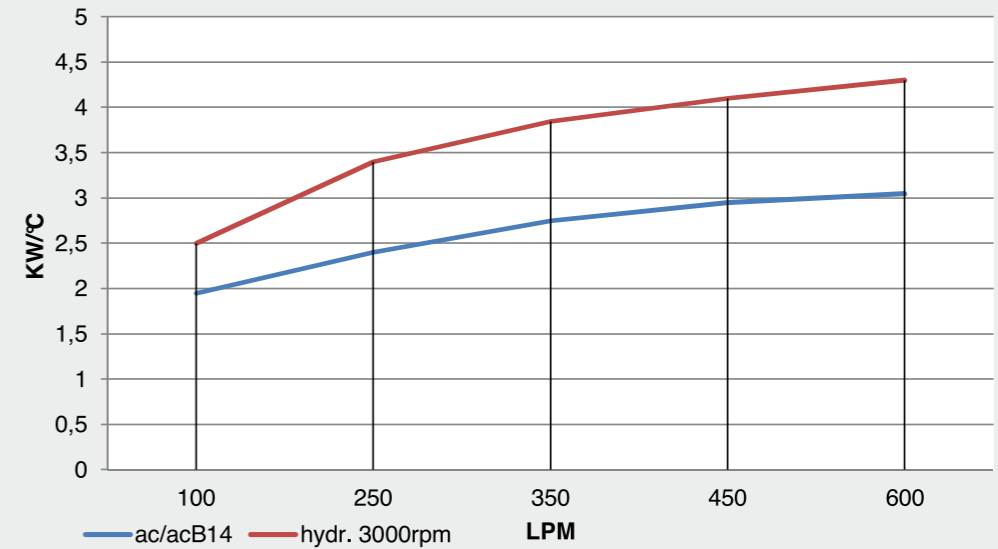

**DIAGRAMMA PERDITE DI CARICO - PRESSURE DROP DIAGRAM**

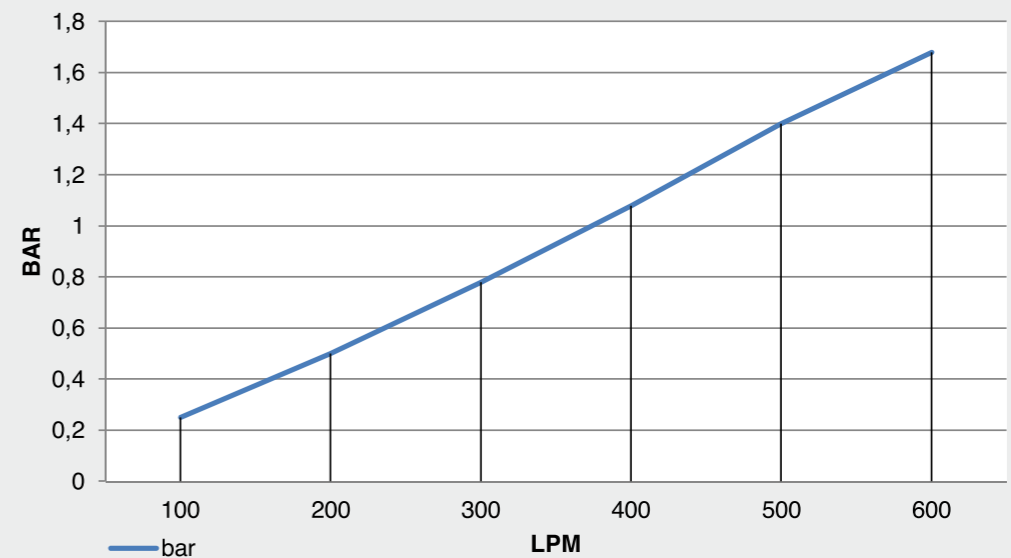

Portata olio - Oil flow: 100-600 lt/1'