

LMP 400 - 401 430 - 431

Maximum pressure 60 bar
Flow rates to 740 l/min



Technical data

Filter housing (Materials)

- Head: Anodised Aluminium
- Housing: Anodised Aluminium
- Bypass valve: Steel

Pressure

LMP 400 length: 2 - 3 - 4

- Working pressure: 60 bar (6 MPa)
- Test pressure: 90 bar (9 MPa)
- Burst pressure: 180 bar (18 MPa)
- Pulse pressure fatigue test: 1.000.000 cycles with pressure from 0 to 60 bar (6 MPa)

LMP 400 length: 5 - 6

- Working pressure: 50 bar (5 MPa)
- Test pressure: 75 bar (7,5 MPa)
- Burst pressure: 150 bar (15 MPa)
- Pulse pressure fatigue test: 1.000.000 cycles with pressure from 0 to 50 bar (5 MPa)

Temperature

- From -25 °C to +110 °C

Bypass valve

- Opening pressure 3,5 bar \pm 10%
- Other opening pressures on request.

Δp Elements type

- Microfibre filter elements series N-W: 20 bar
- Fluid flow through the filter element from OUT to IN.

Seals

- Standard NBR series A
- Optional FPM series V

LMP 400 FILTERS ARE PROVIDED FOR VERTICAL MOUNTING

Weights (kg)

Length	2	3	4	5	6
• LMP400	7,20	8,10	8,80	11,9	14,4

Volumes (dm³)

Length	2	3	4	5	6
• LMP400	3,50	5,00	6,50	9,50	13,5

Connections

- LMP 400-430: In-line Inlet/Outlet
- LMP 401-431: 90° Inlet/Outlet

Filter housings Δp pressure drop

The curves are plotted utilising mineral oil with density of 0,86 kg/dm³ to ISO 3968.

Δp varies proportionally with density.

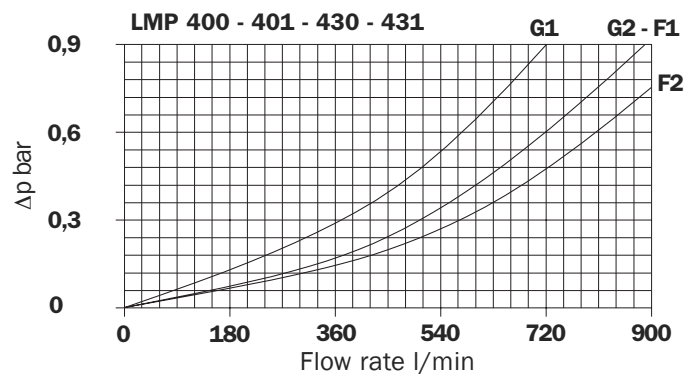

Valves

Bypass valve pressure drop

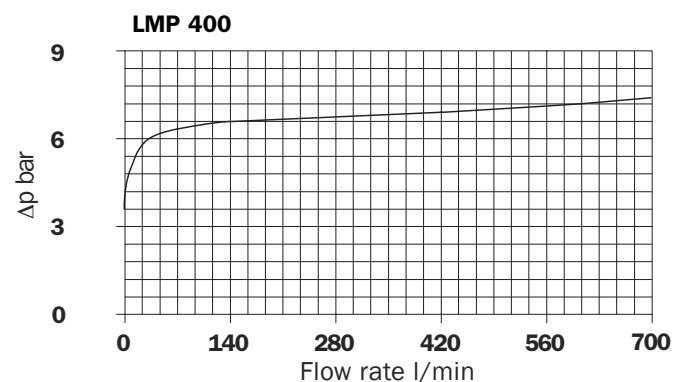

Recommended maximum flow rate

- Pressure drop of filter assembly equal to Δp 0,6 bar.
- Oil kinematic viscosity 30 mm²/s (cSt).
- Density 0,86 kg/dm³.
- Connections of filter under test G 2 1/2".

Filtration

Leng.	A03	A06	A10	A16	A25	P10	P25	M25
LMP400-401	2	180	215	325	360	460	270	500
430-431	3	245	295	420	460	540	580	600
	4	305	350	480	510	575	600	630
	5	405	445	550	600	660	640	670
	6	450	520	610	630	670	650	670

Flow rate l/min

LMP 400

(length 2 - 3 - 4)

LMP 401

(length 2 - 3 - 4)

LMP 400

(length 5 - 6)

LMP 401

(length 5 - 6)

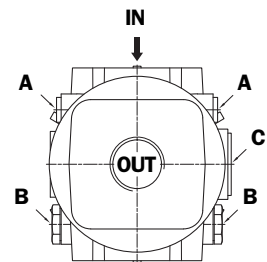
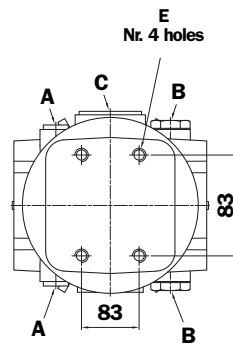
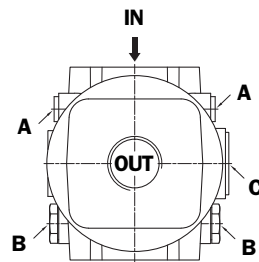
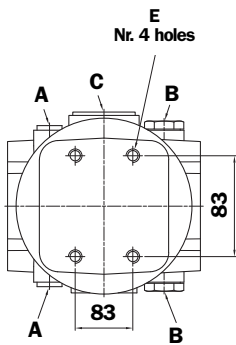
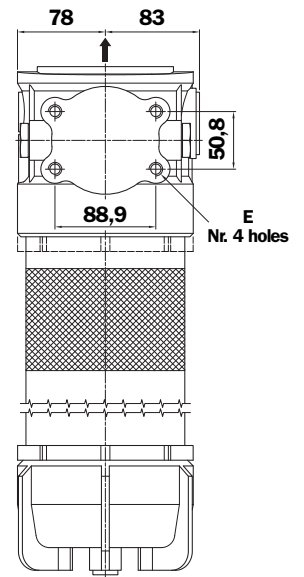
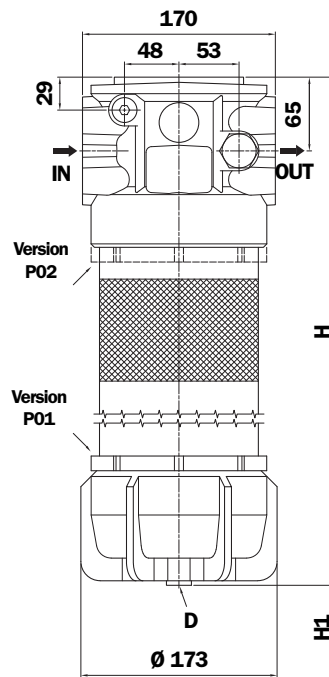
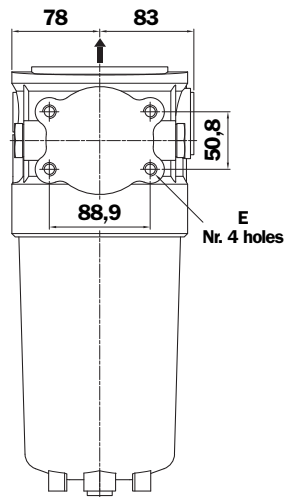
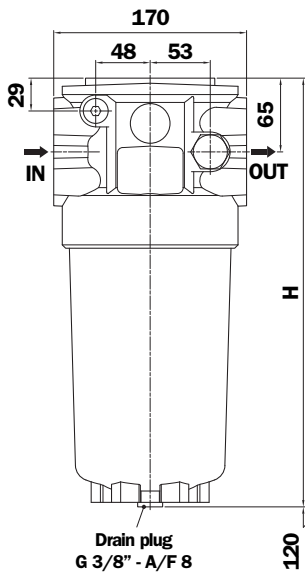

LMP 400

Length Filter	H mm
2	378
3	478
4	578

LMP 401

Length Filter	H mm	H1 mm	H2 mm
5	828	120	660
6	1158	120	990

LMP 400 - 401 Thread IN - OUT connections

Type	Size	E Depth 20 mm
G1	G 1 1/2"	M12
G2	G 2"	M12
G3	1 1/2" NPT	1/2" UNC
G4	2" NPT	1/2" UNC
G5	SAE 24 - 17/8" - 12 UN	1/2" UNC
G6	SAE 35 - 2 1/2" - 12 UN	1/2" UNC

LMP 400 - 401 Flange IN - OUT connections

Type	Size	E Depth 20 mm
F1	2" SAE 3000 psi/M	M12
F2	2 1/2" SAE 3000 psi/M	M12
F3	2" SAE 3000 psi/UNC	1/2" UNC
F4	2 1/2" SAE 3000 psi/UNC	1/2" UNC

- A Breather plug
G 3/8" - A/F 8
- B Indicator port
Plug T2 - A/F 30
- C Bypass valve
A/F 14
- D Oil drain plug
G 3/8" - A/F 8

LMP 430

(length 5 - 6)

LMP 431

(length 5 - 6)

Option P02 for LMP 430 - 431

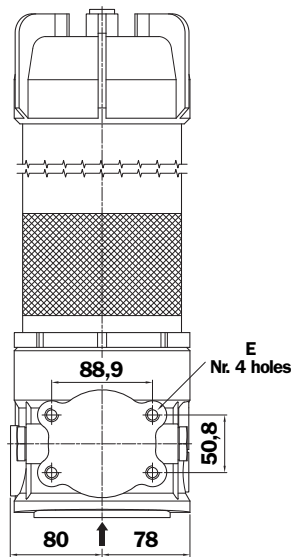
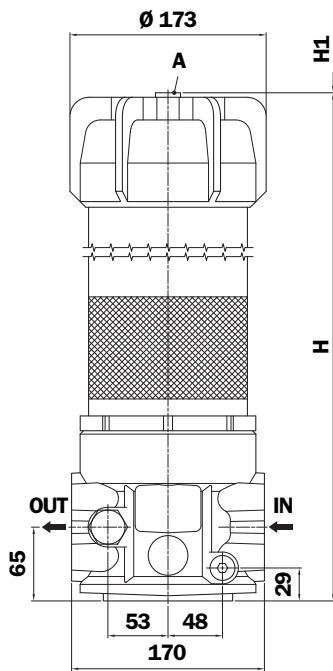
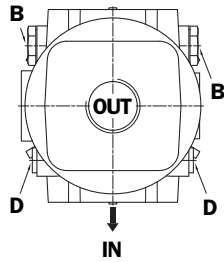
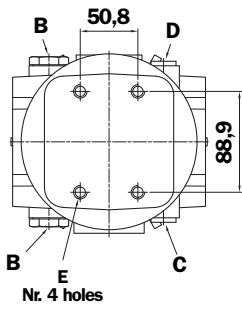

Option P02 "Internal tube for reduced flow rate" is recommended for flow rate values below 100/150 l/min. The use of option P02 makes it easier to fill the housing with the operating fluid.

P02 "Internal tube for reduced flow rates"

LMP 430 - 431

Length Filter	H mm	H1 mm
5	828	660
6	1158	990

Thread IN - OUT connections

Type	Size	E Depth 20 mm
G1	G 1 1/2"	M12
G2	G 2"	M12
G3	1 1/2" NPT	1/2" UNC
G4	2" NPT	1/2" UNC
G5	SAE 24 - 1 7/8" - 12 UN	1/2" UNC
G6	SAE 32 - 2 1/2" - 12 UN	1/2" UNC

Flange IN - OUT connections

Type	Size	E Depth 20 mm
F1	2" SAE 3000 psi/M	M12
F2	2 1/2" SAE 3000 psi/M	M12
F3	2" SAE 3000 psi/UNC	1/2" UNC
F4	2 1/2" SAE 3000 psi/UNC	1/2" UNC

A	Breather plug G 3/8" - A/F 8
B	Indicator port Plug T2 - A/F 30
D	Oil drain plug G 3/8" - A/F 8

Spare parts

LMP 400 - 401 (length 2 - 3 - 4)

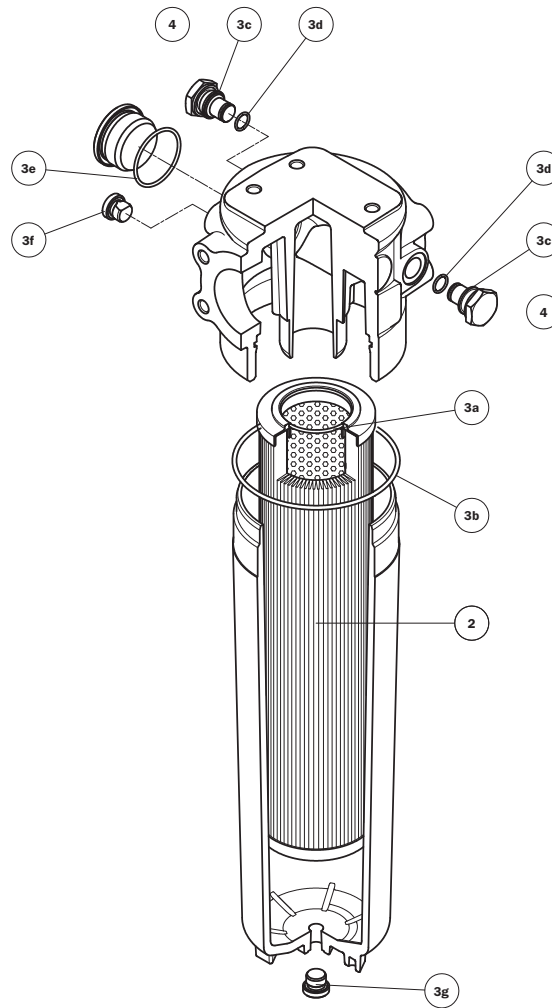

Item	Description	Q.ty	FILTER Series LMP 400 - 401	
1	Filter assembly	1	See order table	
2	Filter element	1	See order table	
3	Seal Kit	1	NBR 02050391	FPM 02050392
3a	Filter element O-Ring	1	O-R 3237 Ø 59,99 x 2,62	
3b	O-Ring for housing	1	O-R 4525 Ø 132,95 x 3,53	
3c	Seal	2	01030058 (HNBR)	01030046 (FPM)
3d	O-Ring for indicator	2	O-R 2050 Ø 12,42 x 1,78	
3e	By-pass plug O-Ring	1	O-R 3193 Ø 48,90 x 2,62	
3f	Breather plug	2	01029436	
3g	Drain plug	1	G 3/8" with seal	
4	Indicator connection plug	1	T2H	T2V

Spare parts

LMP 400 - 401 (length 5 - 6)

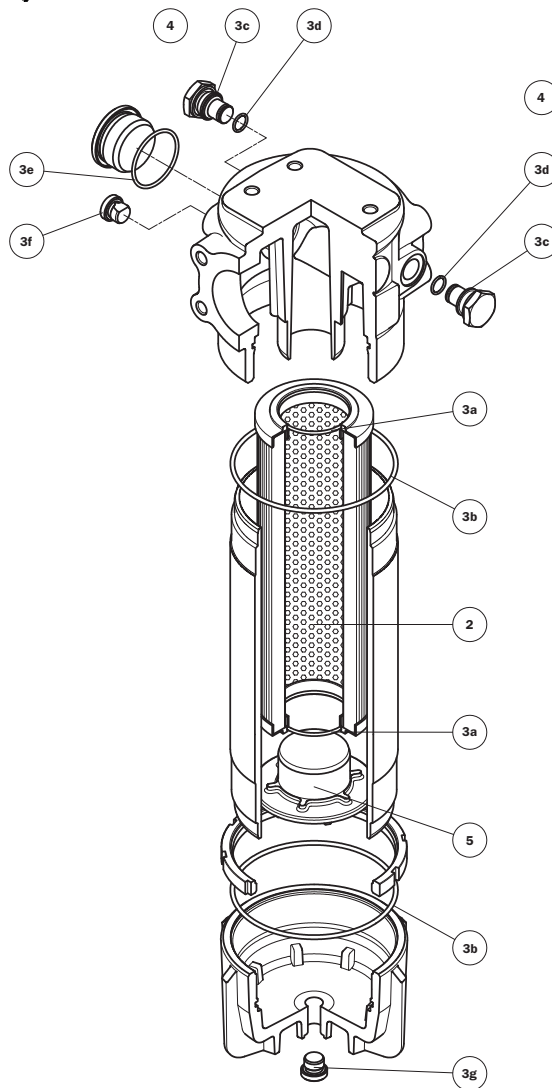

Item	Description	Q.ty	FILTER Series LMP 400 - 401	
1	Filter assembly	1	See order table	
2	Filter element	1	See order table	
3	Seal Kit	1	NBR 02050393	FPM 02050394
3a	Filter element O-Ring	2	O-R 3237 Ø 59,99 x 2,62	
3b	O-Ring for housing	2	O-R 4525 Ø 132,95 x 3,53	
3c	Seal	2	01030058 (HNBR)	01030046 (FPM)
3d	O-Ring for indicator	2	O-R 2050 Ø 12,42 x 1,78	
3e	By-pass plug O-Ring	1	O-R 3193 Ø 48,90 x 2,62	
3f	Breather plug	2	01029436	
3g	Drain plug	1	G 3/8" with seal	
4	Indicator connection plug	2	T2H	T2V
5	Housing spigot	1	01044108	

Spare parts

LMP 430 - 431 (length 5 - 6)

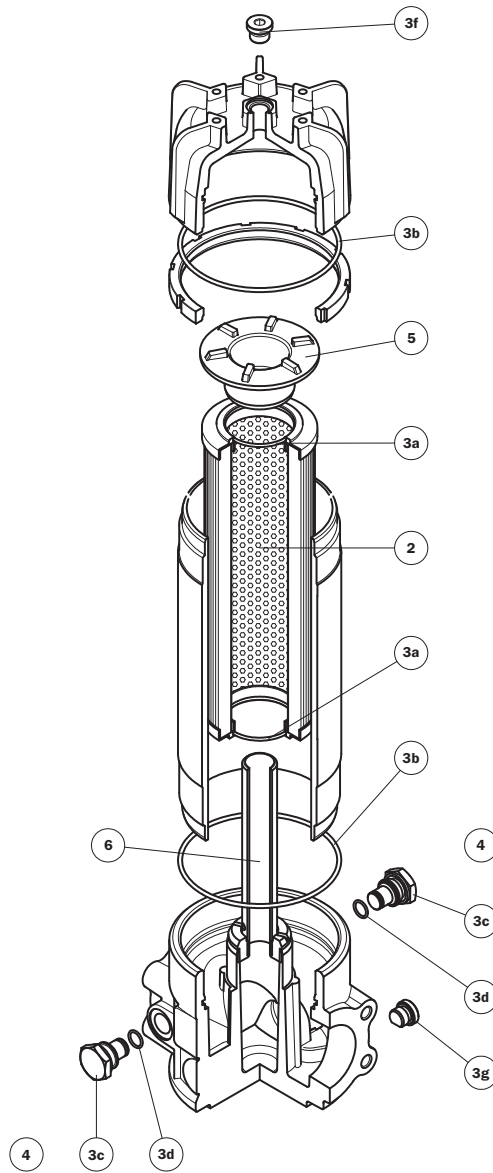

Item	Description	Q.ty	FILTER Series LMP 430 - 431	
1	Filter assembly	1	See order table	
2	Filter element	1	See order table	
3	Seal Kit	1	NBR 02050393	FPM 02050394
3a	Filter element O-Ring	2	O-R 3237 Ø 59,99 x 2,62	
3b	O-Ring for housing	2	O-R 4525 Ø 132,95 x 3,53	
3c	Seal	2	01030058 (HNBR)	01030046 (FPM)
3d	O-Ring for indicator	2	O-R 2050 Ø 12,42 x 1,78	
3f	Breather plug	1	01029436	
3g	Drain plug	2	G 3/8" with seal	
4	Indicator connection plug	2	T2H	T2V
5	Housing spigot	2	Spigot no bypass: 01044108 Spigot with bypass: 02001414	
6	Tube assembly	1	Length 5 - 02025041 Length 6 - 02025042	

Ordering information LMP 400 - 431

Filter assembly LMP

	1	2	3	4	5	6	7	8a
	<input type="checkbox"/>	<input type="checkbox"/>	<input type="checkbox"/>	<input type="checkbox"/>	<input type="checkbox"/>	<input type="checkbox"/>	<input type="checkbox"/>	<input type="checkbox"/>
Example: LMP	400	4	B	A	G3	A10	N	P01

Filter element CU

	1	2	6	4	7	8b
	<input type="checkbox"/>	<input type="checkbox"/>	<input type="checkbox"/>	<input type="checkbox"/>	<input type="checkbox"/>	<input type="checkbox"/>
Example: CU	400	4	A10	A	N	P01

1 - Style

Filter	Filter element
<input type="checkbox"/> 400	<input type="checkbox"/> 400
<input type="checkbox"/> 401	<input type="checkbox"/> 400
<input type="checkbox"/> 430	<input type="checkbox"/> 400
<input type="checkbox"/> 431	<input type="checkbox"/> 400

2 - Filter length

Length 2 - 3 - 4	2	3	4
<input type="checkbox"/> 400	<input type="checkbox"/>	<input type="checkbox"/>	<input type="checkbox"/>
<input type="checkbox"/> 401	<input type="checkbox"/>	<input type="checkbox"/>	<input type="checkbox"/>

Length 5 - 6	5	6
<input type="checkbox"/> 400	<input type="checkbox"/>	<input type="checkbox"/>
<input type="checkbox"/> 401	<input type="checkbox"/>	<input type="checkbox"/>

Length 5 - 6	5	6
<input type="checkbox"/> 430	<input type="checkbox"/>	<input type="checkbox"/>
<input type="checkbox"/> 431	<input type="checkbox"/>	<input type="checkbox"/>

3 - Valves

<input type="checkbox"/> S	Without bypass
<input type="checkbox"/> B	With bypass (opening pressure: on request)

4 - Filter seals

<input type="checkbox"/> A	NBR
<input type="checkbox"/> V	FPM
<input type="checkbox"/> W	NBR (compatible with fluid HFA, HFB, HFC)

5 - Connections

Threaded

LMP 400 - 431

Type	Size
G1	G 1 1/2"
G2	G 2"
G3	1 1/2" NPT
G4	2" NPT
G5	SAE 24 - 1 7/8" - 12 UN
G6	SAE 32 - 2 1/2" - 12 UN

Flanged

LMP 400 - 431

Type	Size
F1	2" SAE 3000 psi/M
F2	2 1/2" SAE 3000 psi/M
F3	2" SAE 3000 psi/UNC
F4	2 1/2" SAE 3000 psi/UNC

6 - Filter element

<input type="checkbox"/> A03	Inorganic microfibre 3 µm	Absolute filtration Inorganic Microfibre βx (c) ≥ 1000
<input type="checkbox"/> A06	Inorganic microfibre 6 µm	
<input type="checkbox"/> A10	Inorganic microfibre 10 µm	
<input type="checkbox"/> A16	Inorganic microfibre 16 µm	
<input type="checkbox"/> A25	Inorganic microfibre 25 µm	
<input type="checkbox"/> M25	Wire mesh 25 µm	Nominal Filtration
<input type="checkbox"/> M60	Wire mesh 60 µm	
<input type="checkbox"/> M90	Wire mesh 90 µm	
<input type="checkbox"/> P10	Resin - Impregnated paper	Nominal Filtration
<input type="checkbox"/> P25	Resin - Impregnated paper	

7 - Max filter element differential pressure

<input type="checkbox"/> N	Δp 20 bar
-----------------------------------	-----------

8 - Option

a - Filter

<input type="checkbox"/> P01	MP Filtri standard
<input type="checkbox"/> P02	Maintenance from base of housing (only for LMP 400 - 401 length 5 - 6)
<input type="checkbox"/> P02	With internal tube reduced flow rate (only for LMP 430 - 431)
<input type="checkbox"/> Pxx	Customer request

b - Filter element

<input type="checkbox"/> P01	MP Filtri standard
<input type="checkbox"/> Pxx	Customer request

For Clogging Indicator:
See page 318

MP Filtri - The filter functions as described in this bulletin are valid exclusively for original MP Filtri filter elements and replacement parts. All rights reserved.

The data in this publication are purely guideline. MP Filtri reserves the right to make changes to the models described herein at any time it deems fit in relation to technical or commercial requirements. The colours of the products shown on the cover are purely guideline. Copyright. All rights reserved.